

URBAN GUIDANCE SIGNING

SECTIONS

- 9.0 Contents
- 9.1 Introduction
- 9.2 Urban Street Hierarchy
- 9.3 Urban Guidance Signing Principles
- 9.4 Urban Local Destination Signing
- 9.5 Urban Tourist Destination Signing
- 9.6 Applications of Urban Guidance Signing
- 9.7 Property Identification

MAY 2012



SARTSM – VOL 2

CHAPTER

9

TITLE			
SOUTH AFRICAN ROAD TRAFFIC SIGNS MANUAL		Volume 2 Chapter 9	
ISBN	STATUS Digitised Version	DOT FILE 000/0/0/0	DATE Digitised May 2012
DIGITISING CARRIED OUT BY			
Transport and Traffic Technology Africa (Pty) Ltd P O Box 1109 SUNNINGHILL 2157			
COMMISSIONED BY			
Department of Transport Private Bag X193 PRETORIA 0001			
ORIGINAL AUTHOR		PUBLISHER ENQUIRIES	
D Bain		Director-General: Transport Private Bag X193 PRETORIA 0001	
It is impossible for a publication of this nature to free of errors. It would be appreciated if errors be brought to the notice of -			
Director-General: Transport Department of Transport Infrastructure Network Management Private Bag X193 PRETORIA 0001			
COPYRIGHT			
This publication is protected by copyright under the Bern Convention. In terms of the Copyright Act No. 98 of 1978, no part of this publication may be produced or transmitted in any form or by any means, electronic or mechanical, including photocopying, recording or by any information storage or retrieval system, without permission in writing from the publisher.			
© National Department of Transport 1999, 2012			
KEYWORDS			
ROAD SIGN, ROAD MARKING, REGULATORY, WARNING			
COST: VOLUME 2			
VOLUME SET R			
Chapter 1	R	Chapter 11	R
Chapter 2	R	Chapter 12	R
Chapter 3	R	Chapter 13	R
Chapter 4	R	Chapter 14	R
Chapter 5	R	Chapter 15	R
Chapter 6	R	Chapter 16	R
Chapter 7	R	Chapter 17	R
Chapter 8	R	Chapter 18	R
Chapter 9	R	Chapter 19	R
Chapter 10	R		

Reproduced under Government Printers Authorization No. 11542 dated 7th July 2017

CHAPTER 9: URBAN GUIDANCE SIGNING

CONTENTS

9.0.1 Sections and Subsections

Number	Title	Page No.
9.0	CONTENTS	9.0.1
9.0.1	Sections and Subsections	9.0.1
9.0.2	Figures	9.0.3
9.0.3	Tables	9.0.4
9.0.4	Level 2 Warrants	9.0.4
9.1	INTRODUCTION	9.1.1
9.1.1	General	9.1.1
9.1.2	Concept of Urban Guidance Signing	9.1.1
9.1.3	Hierarchy of Urban Guidance Signing	9.1.2
9.1.4	The Urban Guidance Signing Process	9.1.2
9.1.5	Volume 1 References	9.1.2
9.1.6	Volume 2 References	9.1.7
9.1.7	Volume 4 References	9.1.7
9.2	URBAN STREET HIERARCHY	9.2.1
9.2.1	Mobility and Accessibility	9.2.1
9.2.2	Urban Street Classification	9.2.2
9.2.3	Route Optimisation	9.2.5
9.2.4	Route Numbering	9.2.5
9.2.5	Peri-Urban Areas	9.2.6
9.3	URBAN GUIDANCE SIGNS	9.3.1
9.3.1	General	9.3.1
9.3.2	Urban Navigation Principles	9.3.1
9.3.3	Typical Urban Street Networks	9.3.2
9.3.4	Selection of Destinations	9.3.6
9.3.5	Preparing an Interim Urban Guidance Signing Plan	9.3.8
9.3.6	The "Layer" Approach	9.3.10
9.3.7	Minimum Urban Guidance Signing	9.3.10
9.3.8	Discussion on Figure 9.14	9.3.10
9.3.9	Selection of Urban Guidance Signing Level	9.3.12
9.3.10	Discussion on Figure 9.15	9.3.12
9.3.11	Worked Examples for Figure 9.15	9.3.14
9.3.12	The Urban Guidance Signing Plan	9.3.14
9.3.13	Minimum Requirement - Short Term Plan	9.3.16
9.3.14	Medium to Long Term Plan	9.3.16
9.3.15	Detail Sign Design	9.3.16
9.3.16	Sign Maintenance Management Plan	9.3.18
9.4	URBAN LOCAL DESTINATION SIGNING	9.4.1
9.4.1	General	9.4.1
9.4.2	Local Direction Signing Principles	9.4.2
9.4.3	Classification of Local Destinations	9.4.4
9.4.4	Signface Design Principles	9.4.4
9.4.5	Symbols	9.4.6
9.4.6	Shape, Size and Colours	9.4.6
9.4.7	Warrants - General	9.4.6
9.4.8	Warrants for Specific Urban Local Destination Types	9.4.7

Number	Title	Page No.
9.5	URBAN TOURIST DESTINATION SIGNING	9.5.1
9.5.1	General	9.5.1
9.5.2	Structure of Tourism Organisations	9.5.2
9.5.3	Urban Tourist Direction Signing Principles	9.5.2
9.5.4	Classification	9.5.5
9.5.5	Signface Design Principles	9.5.5
9.5.6	Symbols	9.5.6
9.5.7	Shape, Size and Colours	9.5.6
9.5.8	High Density Tourism Areas/Tourist Areas	9.5.8
9.5.9	Tourist Information Centres, Bureaux or Laybys	9.5.13
9.5.10	Warrants for Signing Urban Tourist Destinations	9.5.17
9.5.11	Level 1 Warrant Criteria	9.5.18
9.5.12	Level 2 Warrant Criteria – Tourist Attractions: All Groups	9.5.18
9.5.13	Level 2 Warrant Criteria – Tourist Attractions: Group A1 and A2: National and Provincial Parks	9.5.19
9.5.14	Level 2 Warrant Criteria – Tourist Attractions: Group A3: Resort Attractions	9.5.19
9.5.15	Level 2 Warrant Criteria – Tourist Attractions: Group A4: Scenic Attractions	9.5.20
9.5.16	Level 2 Warrant Criteria – Tourist Attractions: Group A5: Sports Attractions	9.5.22
9.5.17	Level 2 Warrant Criteria – Tourist Attractions: Group A6: Wildlife Attractions	9.5.24
9.5.18	Level 2 Warrant Criteria – Tourist Attractions: Group A7: Historic Attractions	9.5.28
9.5.19	Level 2 Warrant Criteria – Tourist Attractions: Group A8: Coastal Attractions	9.5.30
9.5.20	Level 2 Warrant Criteria – Tourist Attractions: Group A9: Arts & Crafts Attractions	9.5.33
9.5.21	Level 2 Warrant Criteria – Tourist Attractions: Group A10: Cultural Attractions	9.5.37
9.5.22	Level 2 Warrant Criteria – Tourist Attractions: Group A11: Adventure Attractions	9.5.38
9.5.23	Level 2 Warrant Criteria – Tourist Attractions: Group A12: Farming Attractions	9.5.40
9.5.24	Level 2 Warrant Criteria – Tourist Attractions: Group A13: General Attractions	9.5.43
9.5.25	Level 2 Warrant Criteria – Emergency Services: Group B1:	9.5.44
9.5.26	Level 2 Warrant Criteria – Vehicle Services: Group B2:	9.5.44
9.5.27	Level 2 Warrant Criteria – Truck Rest and Services: Group B3:	9.5.46
9.5.28	Level 2 Warrant Criteria – Food Services: Group B4:	9.5.46
9.5.29	Level 2 Warrant Criteria – General Services: Group B5:	9.5.47
9.5.30	Level 2 Warrant Criteria – Rest and Service Areas: Group B6:	9.5.50
9.5.31	Level 2 Warrant Criteria – Vehicle Class: Group B7:	9.5.51
9.5.32	Level 2 Warrant Criteria – Accommodation: Group C1:	9.5.51
9.5.33	Level 3 Warrant Criteria: Signface Design:	9.5.54
9.6	APPLICATIONS OF URBAN GUIDANCE SIGNING	9.6.1
9.6.1	General	9.6.1
9.6.2	Applications of Location Signs	9.6.1
9.6.3	Applications of Route Marker and Trailblazer Signs	9.6.1
9.6.4	Applications of the Levels of Urban Guidance Signing	9.6.1
9.6.5	Applications of Urban Local and Tourist Direction Signs	9.6.2
9.6.6	Applications of Urban Diagrammatic Signs	9.6.2
9.6.7	Urban Signing Level 0A-S Class “A” Systems Interchange Overhead Signs	9.6.10
9.6.8	Notes on Figure 9.44	9.6.11
9.6.9	Urban Signing Level 0A-A Class “A” Access Interchange Overhead Signs	9.6.12
9.6.10	Notes on Figure 9.45	9.6.13
9.6.11	Urban Signing Level 1A-A Class “A” Access Interchange Ground-Mounted Signs	9.6.14
9.6.12	Notes on Figure 9.46	9.6.15
9.6.13	Urban Signing Level 1A-C Freeway Class “A” – Crossroad Preferred Level	9.6.16
9.6.14	Notes on Figure 9.47	9.6.17
9.6.15	Urban Signing Level 2A- C Freeway Class “A” – Crossroad Minimum Level	9.6.18
9.6.16	Notes on Figure 9.48	9.6.19
9.6.17	Urban Signing Level 1B Class “B” Junctions Preferred Level	9.6.20
9.6.18	Notes on Figure 9.49	9.6.21
9.6.19	Urban Signing Level 2B Class “B” Junctions Intermediate Level 1	9.6.22
9.6.20	Notes on Figure 9.50	9.6.23
9.6.21	Urban Signing Level 3B Class “B” Junctions Intermediate Level 2	9.6.24
9.6.22	Notes on Figure 9.51	9.6.25
9.6.23	Urban Signing Level 4B Class “B” Junctions Minimum Level	9.6.26
9.6.24	Notes on Figure 9.52	9.6.27
9.6.25	Urban Signing Levels 1C and 2C Class “C” Junctions Enhanced and Minimum Levels	9.6.28
9.6.26	Notes on Figure 9.53	9.6.29
9.6.27	Urban Signing Levels 1D and 2D Class “D” Junctions Enhanced and Minimum Levels	9.6.30
9.6.28	Notes on Figure 9.54	9.6.31
9.6.29	Urban Guidance Signing Dual Carriageway with Sliproads	9.6.32
9.6.30	Notes on Figure 9.55	9.6.33

Number.	Title	Page No.
9.6.31	Urban Guidance Signing Dual Carriageway Junction with a Freeway	9.6.34
9.6.32	Notes on Figure 9.56	9.6.35
9.6.33	Urban Guidance Signing Diagrammatic Signs Lane Drop Examples	9.6.36
9.6.34	Notes on Figure 9.57	9.6.37
9.6.35	Urban Guidance Signing Diagrammatic Signs Various Examples	9.6.38
9.6.36	Notes on Figure 9.58	9.6.39
9.6.37	Urban Guidance Signing Diagrammatic Signs Exclusive Turn Lane Examples	9.6.40
9.6.38	Notes on Figure 9.59	9.6.41
9.7	PROPERTY IDENTIFICATION	9.7.1
9.7.1	General	9.7.1
9.7.2	Ground Surface Property Identification	9.7.1
9.7.3	Property Boundary Display	9.7.4

9.0.2 Figures

Figure No.	Title	Page No.
Fig 9.1	Typical Examples of Primary and Secondary Urban Guidance Signs	9.1.3
Fig 9.2	Typical Examples of Secondary and Supplementary Urban Guidance Signs	9.1.4
Fig 9.3	Typical Examples of Urban Guidance Sign Combinations and Urban Location Signs	9.1.5
Fig 9.4	Guidance Sign Hierarchy	9.1.6
Fig 9.5	Road Classification for Signing Purposes	9.2.2
Fig 9.6	Urban Street Hierarchy	9.2.3
Fig 9.7	Mobility/Accessibility Diagram	9.2.4
Fig 9.8	Pre-Trip and In-Trip Information "Layers"	9.3.3
Fig 9.9	Minor Urban Street Networks	9.3.4
Fig 9.10	Major Urban Street Networks	9.3.5
Fig 9.11	Urban Street Classification Related to Guidance Message Type	9.3.7
Fig 9.12	Step Process for an Interim Guidance Signing Plan	9.3.9
Fig 9.13	Minimum Urban Guidance Signing – No Numbered Routes	9.3.11
Fig 9.14	Minimum Urban Guidance Signing – Numbered Routes	9.3.13
Fig 9.15	Decision Chart to Assist Choice of Guidance Signing Level	9.3.15
Fig 9.16	Step Process to an Urban Guidance Signing Plan	9.3.17
Fig 9.17	Basic Urban Guidance Sign Sequence – Freeway Class A1 Access Interchange - 3 Lane Carriageway	9.3.19
Fig 9.18	Basic Urban Guidance Sign Sequence - Freeway Class A1 Access Interchange - 2 Lane Carriageway	9.3.20
Fig 9.19	Basic Urban Guidance Sign Sequence – At-Grade Class B Junction - Preferred Signing Level	9.3.21
Fig 9.20	Basic Urban Guidance Signing – At-Grade Class B Junction – Minimum Signing Level	9.3.22
Fig 9.21	Basic Minimum Urban Guidance Signing – Class C and Class D Junctions	9.3.23
Fig 9.22	Tertiary Level Guidance Information	9.4.3
Fig 9.23	Supplementary Local Direction Signing – Class "B" Route	9.4.10
Fig 9.24	Local Direction Signing – NO Standard Direction Signs	9.4.11
Fig 9.25	Local/Tourist Direction Sign Combinations	9.4.12
Fig 9.26	Local Direction Signing – Tertiary Arterial	9.4.13
Fig 9.27	Structur of Urban Tourism Organisations and Committees	9.5.3
Fig 9.28	Tourist Route or Area Signing Signface Elements and Typical Signs Used at Entry Points or Gateways	9.5.9
Fig 9.29	Signing a High Density Tourist Area with Similar Themed Tourist Routes (see Figure 9.30)	9.5.10
Fig 9.30	Tourist Signs Used to Identify a High Density Tourist Area Tourist Routes (see Figure 9.29)	9.5.11
Fig 9.31	Urban Tourist Information Facilities - 1	9.5.14
Fig 9.32	Urban Tourist Information Facilities - 2	9.5.15
Fig 9.33	Supplementary Tourist Direction Signing – Urban Class "A" Routes	9.5.55
Fig 9.34	Basic Supplementary Tourist Direction Signing – Urban Class "B" Routes	9.5.56
Fig 9.35	Basic Supplementary Tourist Direction Signing – Final Turn	9.5.57
Fig 9.36	Basic Supplementary Tourist Direction Signing – From an Urban/Peri-Urban Tourist Route	9.5.58

Figure No.	Title	Page No.
Fig 9.37	Street Name Signs - Conspicuity/Legibility	9.6.3
Fig 9.38	Recommended Positioning of Street Name Signs	9.6.4
Fig 9.39	Further Difficulties with the Mounting of GL1 Signs	9.6.5
Fig 9.40	Typical Applications of Route Marker Signs	9.6.6
Fig 9.41	Typical Applications of Trailblazer Signs	9.6.7
Fig 9.42	Local Direction and Tourist Direction Signing -1	9.6.8
Fig 9.43	Local Direction and Tourist Direction Signing -2	9.6.9
Fig 9.44	Urban Signing Level 0A-S Class "A" Systems Interchange Overhead Signs	9.6.11
Fig 9.45	Urban Signing Level 0A-A Class "A" Access Interchange Overhead Signs	9.6.13
Fig 9.46	Urban Signing Level 1A-A Class "A" Access Interchange Ground-Mounted Signs	9.6.15
Fig 9.47	Urban Signing Level 1A-C Freeway Class "A" Crossroad Preferred Level	9.6.17
Fig 9.48	Urban Signing Level 2A-C Freeway Class "A" Crossroad Minimum Level	9.6.19
Fig 9.49	Urban Signing Level 1B Class "B" Junctions Preferred Level	9.6.21
Fig 9.50	Urban Signing Level 2B Class "B" Junctions Intermediate Level 1	9.6.23
Fig 9.51	Urban Signing Level 3B Class "B" Junctions Intermediate Level 2	9.6.25
Fig 9.52	Urban Signing Level 4B Class "B" Junctions Minimum Level	9.6.27
Fig 9.53	Urban Signing Level 1C & 2C Class "C" Junctions Enhanced and Minimum Levels	9.6.29
Fig 9.54	Urban Signing Level 1D & 2D Class "D" Junctions Enhanced and Minimum Levels	9.6.31
Fig 9.55	Urban Guidance Signing Dual Carriageway Junction with Sliproads	9.6.33
Fig 9.56	Urban Guidance Signing Dual Carriageway Junction with a Freeway	9.6.35
Fig 9.57	Urban Guidance Signing Diagrammatic Signs Lane Drop Examples	9.6.37
Fig 9.58	Urban Guidance Signing Diagrammatic Signs Various Examples	9.6.39
Fig 9.59	Urban Guidance Signing Diagrammatic Signs Exclusive Turn Lane Examples	9.6.41
Fig 9.60	Ground Surface Property Identification	9.7.2
Fig 9.61	Property Boundary Identification	9.7.3

9.0.3 Tables

Table No.	Title	Page No
Table 9.1	Local Destination Classification	9.4.5
Table 9.2	Classification of Tourism Destinations for Signg Purposes	9.5.6

9.0.4 Level 2 Warrants

Warrant No.	Title	Page No.
GROUP A4		
GFS A4	Scenic Route	9.5.20
GFS A4-1	Nature Reserve	9.5.20
GFS A4-2	National Heritage	9.5.20
GFS A4-3	Botanical Gardens	9.5.20
GFS A4-4	Gardens (Flower)	9.5.21
GFS A4-5	Waterfall	9.5.21
GFS A4-6	Lake or Dam (no watersport)	9.5.21
GFS A4-7	Caves	9.5.21
GFS A4-8	View Point	9.5.21
GFS A4-9	Natural Forest	9.5.22
GFS A4-10	State Forest	9.5.22
GFS A4-11	Mountain/Berg	9.5.22
GROUP A5		
GFS A5	Generic Sports Attractions	9.5.22
GFS A5-1	Motor Racing Track	9.5.23
GFS A5-2	Golf Course (see also symbol GFS A3-1)	9.5.23
GFS A5-3	(Horse) Race Course	9.5.23
GFS A5-4	Equestrian Events (other than exclusive horse racing venues see GFS A5-3)	9.5.23
GFS A5-5	Fishing	9.5.23
GFS A5-6	Cricket Field	9.5.24
GFS A5-7	Swimming Pool	9.5.24
GFS A5-8	Sports Stadium (see also generic symbol GFS A5)	9.5.24

Warrant No.	Title	Page No.
GROUP A6		
GFS A6	Generic Wildlife Attractions	9.5.24
GFS A6-1	Conservancy Area	9.5.24
GFS A6-2	Game Reserve (see also generic symbol GFS A6)	9.5.25
GFS A6-3	Bird Park/Sanctuary	9.5.25
GFS A6-4	Zoo (see also generic symbol GFS A6)	9.5.25
GFS A6-5	Snake Park	9.5.26
GFS A6-6	Crocodile Park	9.5.26
GFS A6-7	Rhino Park (see also generic symbol GFS A6)	9.5.27
GFS A6-8	Lion Park (see also generic symbol GFS A6)	9.5.27
GROUP A7		
GFS A7	Generic Historic Attractions	9.5.28
GFS A7-1	National Monument	9.5.28
GFS A7-2	Museum (see also generic symbol GFS A7 and Maritime Museum GFS A8-2)	9.5.28
GFS A7-3	Historic Mine (see also generic symbol GFS A7)	9.5.29
GFS A7-4	Historic Railway (see also generic symbol GFS A7)	9.5.29
GFS A7-5	Historic Battlefield (see also generic symbol GFS A7, National Monument symbol GFS A7-1 and Museum symbol GFS A7-2)	9.5.29
GFS A7-6	Historic Cemetery (see also generic symbol GFS A7 and National Monument symbol GFS A7-1)	9.5.29
GFS A7-7	Geological Site (see also generic symbol GFS A7)	9.5.30
GROUP A8		
GFS A8	Generic Coastal Attractions	9.5.30
GFS A8-1	Marine Reserve (see also generic symbol GFS A8)	9.5.30
GFS A8-2	Maritime Museum (see also generic symbol GFS A8 and Museum (Site Museum) symbol GFS A7-2)	9.5.30
GFS A8-3	Aquarium (see also generic symbol GFS A8)	9.5.31
GFS A8-4	Whales (see also generic symbol GFS A8)	9.5.31
GFS A8-5	Dolphins (see also generic symbol GFS A8)	9.5.31
GFS A8-6	Lighthouse (see also generic symbol GFS A8)	9.5.31
GFS A8-7	Dockyard (see also generic symbol GFS A8)	9.5.32
GFS A8-8	Boat Launch (see also generic symbol GFS A8)	9.5.32
GFS A8-9	(Coastal) Fishing (see also generic symbol GFS A8)	9.5.32
GFS A8-10	Crayfish (see also generic symbol GFS A8)	9.5.32
GFS A8-11	Oceanarium (see also generic symbol GFS A8)	9.5.33
GFS A8-12	Beach (see also generic symbol GFS A8)	9.5.33
GROUP A9		
GFS A9	Generic Arts & Crafts Attractions	9.5.33
GFS A9-1	Painting and Drawing (see also generic symbol GFS A9)	9.5.33
GFS A9-2	Pottery (see also generic symbol GFS A9)	9.5.34
GFS A9-3	Jewellery (see also generic symbol GFS A9)	9.5.34
GFS A9-4	Weaving and Knitting (see also generic symbol GFS A9)	9.5.35
GFS A9-5	Leatherwork (see also generic symbol GFS A9)	9.5.35
GFS A9-6	African Arts & Crafts (see also generic symbol GFS A9)	9.5.36
GFS A9-7	Woodwork (see also generic symbol GFS A9)	9.5.36
GFS A9-8	Metalcraft (see also generic symbol GFS A9)	9.5.37
GROUP A10		
GFS A10	Generic Cultural Attractions	9.5.37
GFS A10-1	Theatre (see also generic symbol GFS A10)	9.5.37
GFS A10-2	Amphitheatre (see also generic symbol GFS A10)	9.5.38
GROUP A 11		
GFS A11	Generic Adventure Attractions	9.5.38
GFS A11-1	Hiking Trail (see also generic symbol GFS A11)	9.5.38
GFS A11-2	Horse Trail (see also generic symbol GFS A11)	9.5.38
GFS A11-3	4 x 4 Trail (see also generic symbol GFS A11)	9.5.39
GFS A11-4	Bike Trail (see also generic symbol GFS A11)	9.5.39
GFS A11-5	River Rafting (see also generic symbol GFS A11)	9.5.39
GFS A11-6	Scuba Diving (see also generic symbol GFS A11)	9.5.40
GFS A11-7	Ballooning (see also generic symbol GFS A11)	9.5.40

Warrant No.	Title	Page No.
GROUP A12		
GFS A12	Generic Farming Attractions	9.5.40
GFS A12-1	Wine Cellar (see also generic symbol GFS A12)	9.5.40
GFS A12-2	Wine Route (see also generic symbol GFS A12)	9.5.41
GFS A12-3	Showground (see also generic symbol GFS A12)	9.5.41
GFS A12-4	Cherry Farm (see also generic symbol GFS A12)	9.5.41
GFS A12-5	Ostrich Farm with Ostrich Riding (see also generic symbol GFS A12)	9.5.41
GFS A12-6	Ostrich Farm (see also generic symbol GFS A12)	9.5.42
GFS A12-7	Fish Farm (see also generic symbol GFS A12)	9.5.42
GFS A12-8	Roadside Stall (see also generic symbol GFS A12)	9.5.42
GFS A12-9	Butterfly Farm (see also generic symbol GFS A12)	9.5.42
GROUP A13		
GFS A13	Generic General Attractions	9.5.43
GFS A13-1	Animal Theme Park	9.5.43
GROUP B1		
GFS B1-1	Telephone	9.5.44
GFS B1-2	Police	9.5.44
GFS B1-3	Hospital	9.5.44
GFS B1-4	First Aid	9.5.44
GFS B1-5	SOS Telephones	9.5.44
GROUP B2		
GFS B2-1	Filling Station and Workshop	9.5.44
GFS B2-2	Filling Station	9.5.45
GFS B2-3	Workshop	9.5.45
GFS B2-4	Tow-in Service	9.5.45
GROUP B3		
GFS B3-1	Truck Services	9.5.46
GROUP B4		
GFS B4-1	Restaurant	9.5.46
GFS B4-2	Refreshments and	9.5.47
GFS B4-3	Take-Away	9.5.47
GROUP B5		
GFS B5-1	Parking Area	9.5.47
GFS B5-2	Toilets	9.5.48
GFS B5-3	Shower	9.5.48
GFS B5-4	Drinkable Water	9.5.48
GFS B5-5	Fireplace	9.5.48
GFS B5-6	Cooking Facilities	9.5.49
GFS B5-7	Picnic Area	9.5.49
GFS B5-8	Tourist Information	9.5.49
GFS B5-9	Facilities for Handicapped Persons	9.5.49
GFS B5-10	Roadside Stall	9.5.50
GFS B5-11	Post Office	9.5.50
GFS B5-12	Rural Shop/Café/Corner Shop	9.5.50
GROUP B6		
GFS B6-1	Rest Area Class 1	9.5.50
GFS B6-2	Service Area Class 2	9.5.50
GFS B6-3	Service Area Class 3	9.5.50
GROUP B7		
GFS B7-1	Motor Cars	9.5.51
GFS B7-2	Caravans	9.5.51
GFS B7-3	Buses	9.5.51
GFS B7-4	Trucks	9.5.51

Warrant No.	Title	Page No.
GROUP C1		
GFS C1-1	Hotels, Motels, Inns and Lodges	9.5.52
GFS C1-2	Chalet/Self-Catering Establishments	9.5.52
GFS C1-3	Caravan Parks and/or	9.5.52
GFS C1-4	Camping Sites	9.5.52
GFS C1-5	Guest House	9.5.53
GFS C1-6	Bed and Breakfast and	9.5.53
GFS C1-7	Rooms	9.5.53
GFS C1-8	Youth Hostel	9.5.53
GFS C1-9	Trail Shelter	9.5.53
GFS C1-10	Guest Farm	9.5.53
GFS C1-11	Ethnic (Zulu) Accommodation	9.5.54

Reproduced under Government Printers Authorization No. 11542 dated 7th July 2017

Reproduced under Government Printers Authorization No. 11542 dated 7th July 2017

URBAN GUIDANCE SIGNING

9.1 INTRODUCTION

9.1.1 General

- 1 This chapter has been prepared with the objective of improving on the depth of coverage and guidance given in Volume 1 of the Manual on the subject of urban guidance signing. For a number of reasons direction signing in urban areas is a more complex procedure than in rural areas. A more detailed approach, involving more in-depth research of urban guidance signing needs, has therefore been required in order to evolve more complete guidelines to cater for the wider variety of urban guidance signing applications. These guidelines have been prepared under the jurisdiction of the Urban Signs Working Group of the Route Numbering and Road Traffic Signs Sub-Committee.
- 2 In the context of this chapter "urban" includes all built-up areas with a formal street network, from small towns up to large metropolitan areas incorporating many towns and/or cities. The signing needs of peri-urban areas and by-passed towns are also addressed. **"Guidance" signing comprises all those road signs which contribute towards the on-road visual information system AND which give direction or reassurance to drivers in the process of navigating their way through the road network.**
- 3 Since one of the main objectives in the use of traffic control devices is the safety of road users it can be reasonably accepted that a lack of responsibility and attention to detail in the use of traffic control devices contributes to prevailing poor accident histories in many areas. **In all formally structured urban areas the responsibility for the correct placing and maintenance of all traffic control devices must therefore be clearly established.** Even in informal urban developments, where full administrative structures are not yet in place, there is ultimately a "responsible" authority. Such an authority must accept its responsibility for treating the provision of traffic control devices in such an area in a manner appropriate to an urban area, by for example, providing street name signs.
- 4 It is the nature of many urban administrations that the responsibility for road traffic signs tends to be split between engineering departments, traffic departments, and possibly other departments. When this is the case it is essential that a high degree of co-ordination is set up between departments to avoid inadequate, inconsistent or even conflicting signing. Such a level of co-ordination is particularly appropriate to the provision of urban guidance signs which require a particular traffic engineering approach to their correct provision.
- 5 Volume 1 of the Manual deals with the subject of urban guidance signing in a summarised way and does recognise various difficulties such as the potentially high demand for guidance signing and the difficulty in selecting limited, but appropriate, destination names for use on urban direction signs. Volumes 1 and 4 also detail specific types of urban guidance sign which include

features such as place names or street names which are appropriate to urban areas rather than rural areas. This chapter will utilise the guidance sign "tools" covered in Volume 1 to illustrate as many typical applications of urban guidance signs as is practical. The coverage will also extend to detail on the principles of the preparation of an "Urban Guidance Signing Plan" (see Subsections 9.1.5 to 9.1.7).

- 6 The principles of primary and secondary levels of direction signing, as developed in Volume 1, are appropriate to urban areas, particularly large metropolitan areas. The primary and secondary levels of a direction sign system define the numbered route network. This network links the familiar orientational destinations by which drivers may navigate through the area. The information provided by the system may be supplemented by a lower (tertiary) order direction sign system, indicating tourist or other destinations of importance at a local level. **It should be noted that the information actually displayed on direction signs can also be described in terms of primary and secondary importance. The use of these terms in two inter-related ways can be confusing. For more details on this aspect of direction sign type and signface layout see Subsection 9.1.3 and Figure 9.4.**

9.1.2 Concept of Urban Guidance Signing

- 1 When drivers undertake a journey through or into an area with which they are not familiar they invariably require assistance in the form of navigational aids in order to reach their final destination safely and with minimum disruption to other traffic. Information needed in order to navigate successfully through the road network should be obtained initially before starting the journey from maps, road reports or from directions given in the form of written or verbal messages, AND whilst on the journey from roadside aids. **These roadside aids comprise the guidance sign class.** Guidance signs form a main group in the road sign classification (see Volume 1, Chapter 4, Section 4.0). The following signs make up the guidance sign class (see Figures 9.1 to 9.3):
 - (a) LOCATION signs;
 - (b) ROUTE MARKER signs – including TRAILBLAZER signs;
 - (c) DIRECTION signs;
 - (d) FREEWAY DIRECTION signs;
 - (e) LOCAL DIRECTION signs;
 - (f) TOURISM DIRECTION signs;
 - (g) DIAGRAMMATIC signs.
- 2 A journey may start in one urban area, proceed primarily through rural areas but pass through varying sizes of town on the way, and end in

another urban area. Alternatively a journey into an unfamiliar area may occur wholly within a large metropolitan area. The potential need on such journeys to navigate through several changes of direction is normally much greater in an urban area than in a rural area. This need must be catered adequately for by urban guidance signs.

- 3 Urban guidance signs are used to give directional information to assist drivers to take the correct direction at a junction during their journey. They are also used to give reassurance after turns have been made and to identify "landmarks" along the way. In particular urban guidance signs must identify the final destination on the journey in the form of a street name and some form of property identification.
- 4 The amount of guidance signing provided in an urban area will tend to vary according to the position of the particular street within the urban street network hierarchy, although other factors often affect the signing level.
- 5 Urban guidance signing as a signing system is structured in a hierarchical manner into primary and secondary levels, supplemented as necessary by tourism and local direction signs. **The destinations used on primary and secondary level signs provide directional orientation to drivers, whereas the destinations on tourism and local direction signs should be only of supplementary significance at a local signing level.**

9.1.3 Hierarchy of Urban Guidance Signing

- 1 The whole process of providing road traffic signs has been structured in an orderly manner to assist those who provide the signs, signals and markings to do so in terms of the overall signing system objectives of conformity, accuracy, uniformity, consistency and continuity. Within this overall system guidance signs, and particularly urban guidance signs, have developed a structured hierarchy.
- 2 The most important sub-group within the guidance sign class, that of direction signs, conforms to a hierarchy which is demonstrated to road users in the form of a sign background colour code. In this way direction signs used at the highest level in the road network have a blue background colour and those at lower levels have a green background. In addition to this basic hierarchy supplementary direction may be given, **subject to the appropriate warrants**, for local destinations on white signs or for tourist destinations on brown signs. At the local level in the urban road network local and/or tourist direction signs may be the only direction signs provided. This hierarchy is illustrated in Figures 9.1 to 9.3.
- 3 In Figure 9.1 a selection of typical primary and secondary level urban direction signs is illustrated in Details 9.1.1 to 9.1.5. In each detail the sign on the left is the sign used in advance of the "action" point or exit/turn point and the signs on the right are used at the "action" point. Detail 9.1.1 shows primary signs serving a typical exit from an urban freeway. Orientation for the cross street is not given **on** the freeway because, at the time of exiting the freeway, this is not required. This exit is commonly taken at high speed, so it is preferred **not** to overload drivers with information not relevant to the task in hand. The information given on the freeway is therefore

kept to the minimum of **the route number and cross street name**, with, for locational reference the interchange number and town name. The street name is carried forward to the next two signs (Detail 9.1.2) and additional orientational information is added for the turns at the ramp terminal. Details 9.1.3 to 9.1.5 show typical secondary direction signs appropriate to Class "B" arterial routes. Detail 9.1.3 applies when the cross street name is the same on both sides of the junction whereas Detail 9.1.5 is appropriate if the street name changes from one side to the other at the junction. Detail 9.1.4 is typical for an urban T-junction between two Class "B" routes.

- 4 Figure 9.2 shows in Detail 9.2.1 a typical sequence of secondary level direction signs leading to a Class "A1" freeway, hence the use of a "trailblazing" blue colour for the background of the relevant parts of the signs. Detail 9.2.2 illustrates the full range of metropolitan, regional, provincial and national route marker signs. These signs are appropriate as an initial stand-alone low cost system. Primary and secondary level signs may be supplemented in an at-grade street environment by tourist and/or local direction signs, examples of which are given in Detail 9.2.3.
- 5 Figure 9.3 shows some examples of local and tourism sign combinations together with a selection of typical location guidance signs which identify various points along a route or street.
- 6 There is also an established hierarchy for the information that appears on direction signs. This is illustrated in Figure 9.4 and listed below:
 - (a) primary information - street name or other locational information and, when appropriate, route numbers;
 - (b) secondary information - orientation destinations;
 - (c) tertiary information - supplementary local and/or tourist destinations.
- 7 In addition there is a further hierarchy which is relevant to the level of urban guidance signing to be used, namely the urban street classification. All these different levels of importance will be covered in greater detail in subsequent sections.

9.1.4 The Urban Guidance Signing Process

- 1 The most important overall objective of this chapter is to establish urban guidance signing practices and typical applications which will allow all sizes of urban authority to establish an "Urban Guidance Signing Plan" for their town or city.
- 2 Such "Urban Guidance Signing Plans" will vary in detail according to the position occupied by the town in the regional, provincial or national road network. Such a plan should also offer an affordable, staged implementation method which should concentrate on the basic requirements first, whilst always aiming for the ultimate goal of as close to perfect an urban guidance signing system as possible.

9.1.4 Volume 1 References

- 1 Relevant references in Volume 1 which will not be repeated in this chapter are:
 - (a) general functions of traffic control devices (Sub-section 1.1.5);

(continued on page 9.1.7)

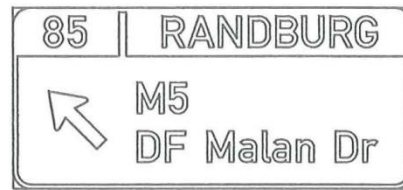
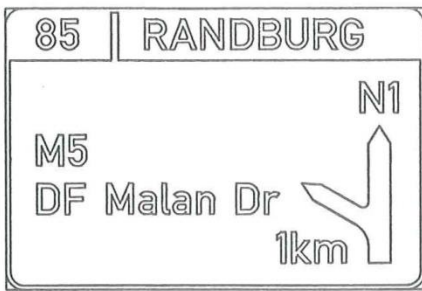

Detail 9.1.1: Primary Level Main-line Freeway Exit Direction Signs



Detail 9.1.2: Secondary Level Freeway Off-ramp Direction Signs



Detail 9.1.3: Secondary Level Direction Signs - At-grade Cross Street

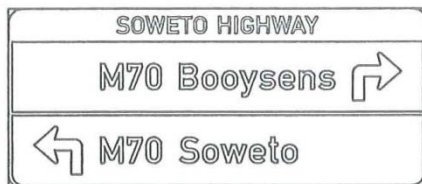

Detail 9.1.4: Secondary Level Direction Signs - At-grade T-junction



Detail 9.1.5: Secondary Level Direction Signs for Cross Street with Street Name Change at Junction

Fig 9.1 Typical Examples of Primary and Secondary Urban Guidance Signs

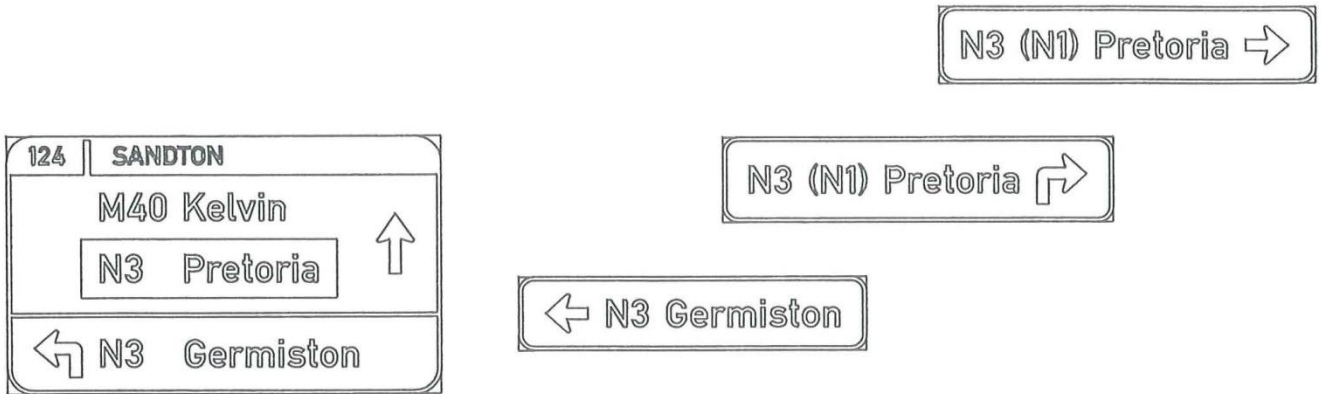

Detail 9.2.1: Cross Street Sign Sequence Entering a Class 'A1' Freeway

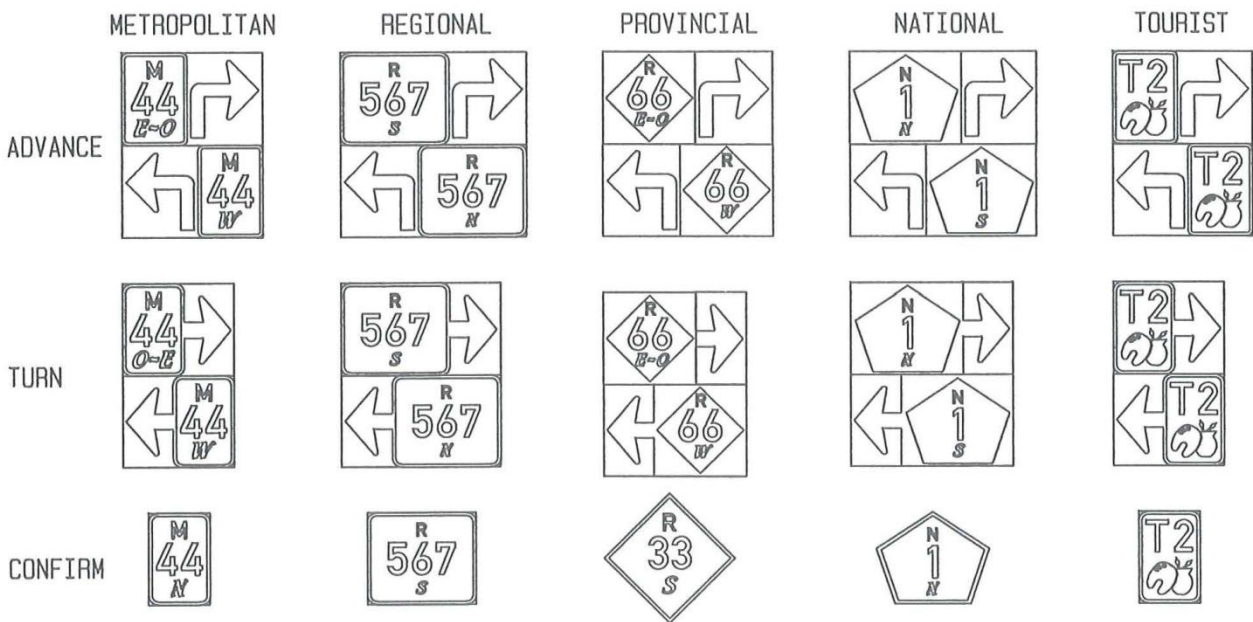

Detail 9.2.2: The Full Range of Route Marker Direction Signs

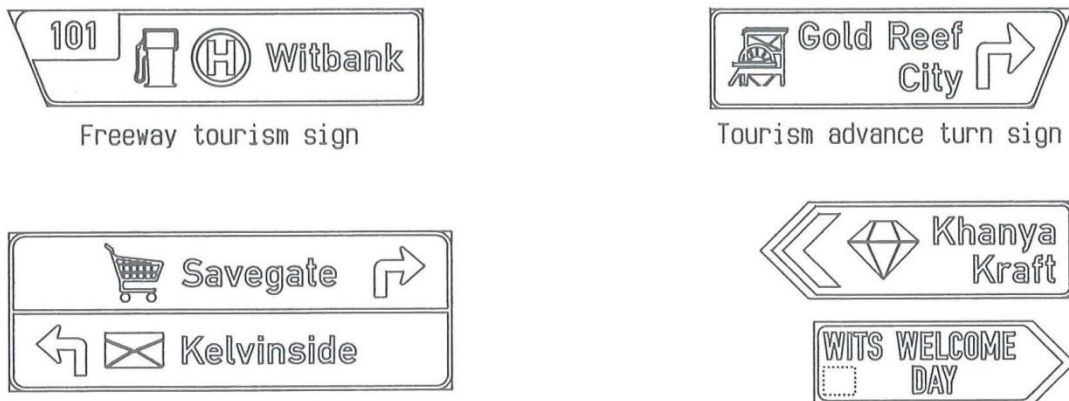

Advance local direction sign

Part-time tourism facility signs

Detail 9.2.3: Typical Tertiary Level Direction Signs (Tourism and Local)

Fig 9.2 Typical Examples of Secondary and Supplementary Urban Guidance Signs

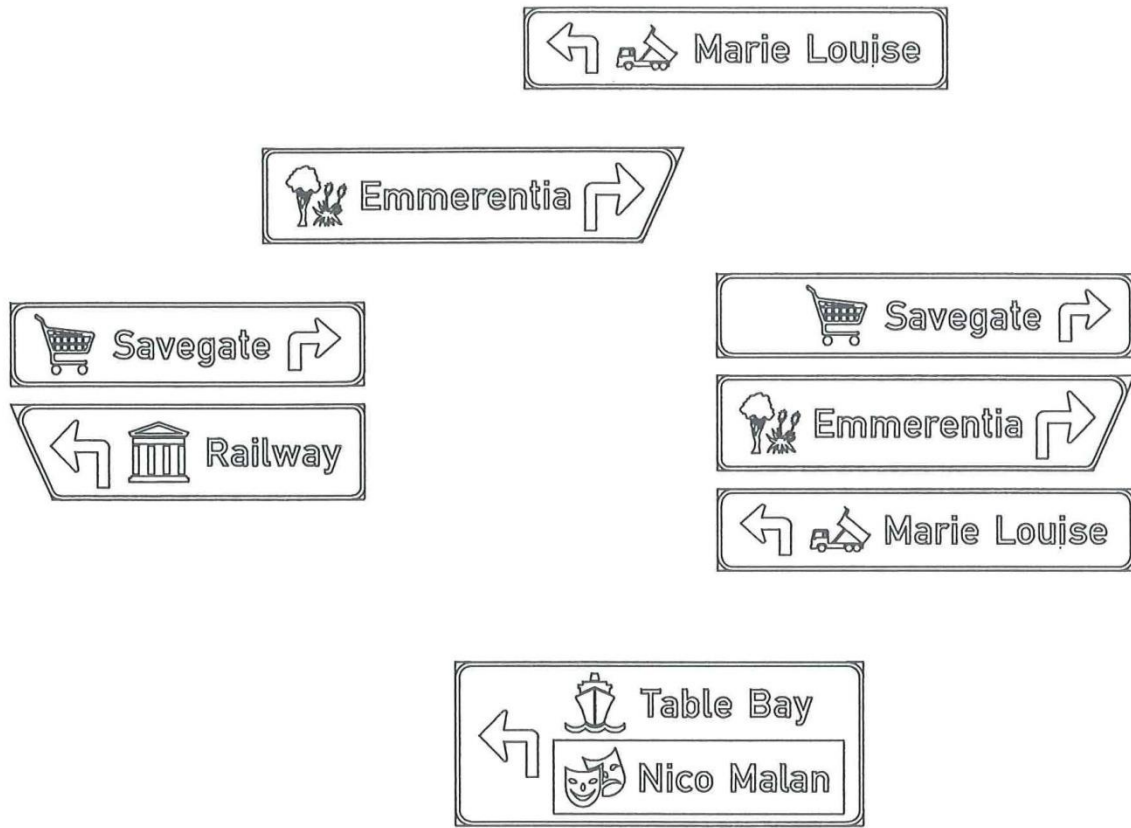

Detail 9.3.1: Various Combinations of Tertiary Level Direction Signs



Street name



Suburb



Town name



Use of crest is optional

Detail 9.3.2: Urban Location Signs

Fig 9.3

Guidance Sign Hierarchy

1. SIGN INFORMATION

INFORMATION LEVEL	SIGNFACE DETAIL
Primary information	Arrow, route number, street name and location
Secondary information	Orientalional destinations
Tertiary information	Local and / or tourism destinations

2. SIGNFACE

CATEGORY	COLOUR CODE
Primary signs (freeways)	A1 White-on-Blue
	A2 White-on-Green
Secondary signs (other streets)	White-on-Green
Supplementary Signs (Tertiary)	White-on-Brown
	Black-on-White

BACKGROUND COLOUR

Detail 9.4.1 Guidance Sign Hierarchical Terminology

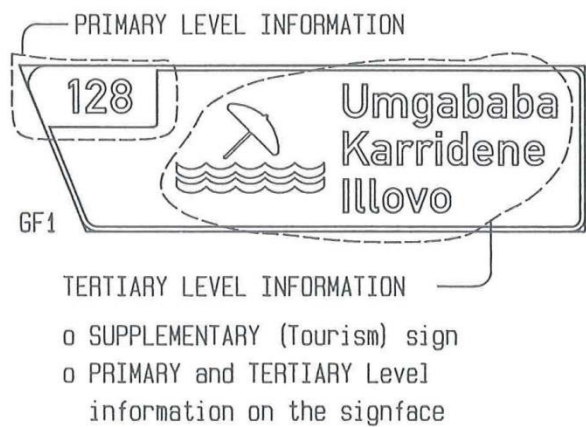
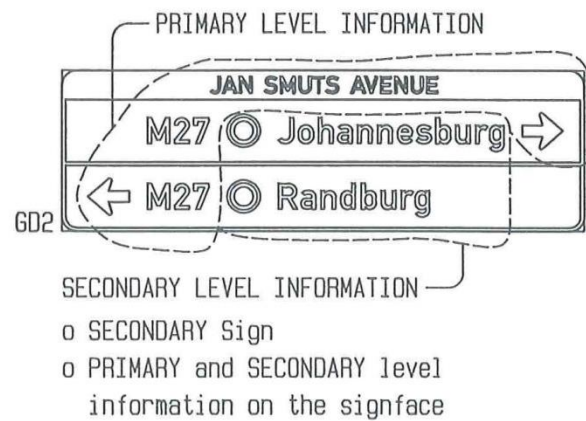
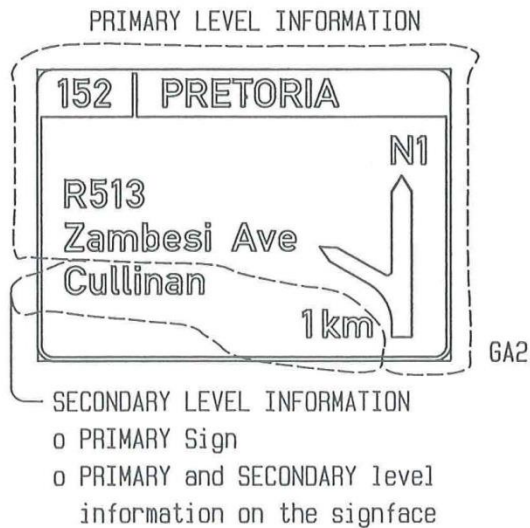

Detail 9.4.2 Examples of Signface Information Hierarchy

Fig 9.4 Typical Examples of Urban Guidance Sign Combinations and Urban Location Signs

(continued from page 9.1.2)

- (b) uniformity of traffic control devices (Subsection 1.1.6);
- (c) principles of signing (Subsection 1.1.9);
- (d) selection of destinations (Subsection 1.1.11);
- (e) road classification for signing purposes (Subsection 1.2.2);
- (f) all of Chapter 4: Guidance Signs but specifically:
 - (i) Section 4.1 - Introduction;
 - (ii) Section 4.5 - Guidance Signing in Urban Areas;
 - (iii) Subsection 4.6.4 - Street Name signs;
 - (iv) Subsection 4.6.5 - Suburb Name signs;
 - (v) Subsection 4.6.6 - Town or City Name signs;
 - (vi) Section 4.7 - Route Marker and Trailblazer Signs;
 - (vii) Section 4.8 - Direction signs;
 - (viii) Section 4.9 - Freeway Direction signs;
 - (ix) Section 4.10 - Tourism Direction signs;
 - (x) Section 4.11 - Local Direction signs;
 - (xi) Section 4.12 - Diagrammatic signs;
- (g) all of Chapter 8: Navigational Aids but specifically:
 - (i) Section 8.1 - Introduction
 - (ii) Subsection 8.2.5 - Guidance signs, confirmation signs, Town and Street name signs;
 - (iii) Subsection 8.2.6 - Property Numbers, Private and Commercial Name signs;
 - (iv) Section 8.3 - Route Optimisation;
 - (v) Section 8.4 - Route Numbering;
 - (vi) Subsection 8.6.6 - Destination Selection for National Freeways in Metropolitan Areas;
 - (vii) Subsection 8.6.7 - Destination Selection at Smaller Urban Areas and Towns By-Passed by Freeways;
- (h) Glossary of Terms;
 - (i) General Terms;
 - (ii) Sign Terms.

9.1.6 Volume 2 References

- 1 Specific applications of various sub-groups of guidance sign are covered in a number of other Volume 2 chapters as follows:
 - (a) Chapter 5: *Freeway Signing*;
 - (b) Chapter 6: *Toll Route Signing*;
 - (c) Chapter 10: *Rural Junction Signing*;
 - (d) Chapter 11: *Signing for Heavy Vehicles*;
 - (e) Chapter 19: *Variable Message Signs*.
- 2 In the case of Chapters 5 and 6 a wider range of applications of freeway signing and toll route signing is covered than in this chapter. Chapter 10 is relevant mainly for comparison purposes to illustrate differences between urban and rural signing standards.

- 3 Chapter 11 includes examples of signing for heavy vehicle routing which may occur in urban areas. Other examples in Chapter 11 include guidance signs of the types which may commonly be required in urban environments. These examples are not repeated in this chapter.
- 4 The coverage of Chapter 19 is very relevant to urban guidance signing. This is particularly the case for the major metropolitan areas where the ability to use variable guidance messages is likely to come into its own for incident management, route selection and toll route messages.

9.1.7 Volume 4 References

- 1 Volume 4 gives all dimensional details for all individually identified guidance sign types. This information is covered as follows:
 - (a) Chapter 4: *Location Signs and Route Marker Signs*;
 - (b) Chapter 5: *Direction Signs*;
 - (c) Chapter 6: *Freeway Direction Signs*;
 - (d) Chapter 7: *Tourism Signs*;
 - (e) Chapter 8: *Diagrammatic Signs*;
 - (f) Chapter 13: *Local Direction Signs*;
 - (g) Chapter 14: *Pedestrian Direction Signs*;
 - (h) Chapter 15: *Toll Direction Signs*.

Reproduced under Government Printers Authorization No. 11542 dated 7th July 2017

9.2 URBAN STREET HIERARCHY

9.2.1 Mobility and Accessibility

1 In planning and traffic engineering terms roads tend to be categorised according to the mobility they provide for traffic, or the accessibility they offer to users of the road network. **These concepts are appropriate to the consideration of a classification for urban streets for signing purposes, since most urban streets cater for both functions, with one predominating over the other to varying degrees.** Urban streets have been classified in a number of different ways in the past, for different purposes. In order to establish a structured approach to the provision of urban guidance signing, it is necessary to determine a classification system for urban streets which can be related to preferred levels of guidance signing. **It should be noted, however, that under typical urban conditions the ability to provide direction signs, or not, is dictated as frequently by the availability, or otherwise, of space to accommodate the signs, as it is by the requirement to conform to a particular preferred signing treatment.**

2 Terminology relating to categories of street has also varied in the past. The following basic terms are used **in this chapter** to describe the functions of different types of street:

- (a) **Arterial streets** are those streets forming a network of routes whose main function is to carry the major traffic movements within the metropolitan or urban area with the emphasis on **mobility** (different traffic and frontage conditions may require sub-categorisation whereby some streets can be expected, and encouraged, to provide more mobility than others) - arterials are usually numbered routes and include freeways;
- (b) **Collector-distributor streets** are those arterial or local streets along which **mobility and accessibility** have very approximately equal priority;
- (c) **Local streets** are all streets not classified as arterial. Local streets should lie wholly within a local traffic area bounded by arterial streets (or other physical features) and should have the primary function to provide **accessibility**. Local streets should not be numbered routes.

These categories are illustrated in Figures 9.5, 9.6 and 9.7.

3 Communities or suburbs may be residential, commercial or industrial. Such communities may be large enough to include arterial streets or they may be of such a size that they individually comprise local traffic areas (ie. are bounded by arterial streets). Alternatively a local traffic area may comprise several smaller communities. In an urban context this measure of a community size is relevant when considering the orienting potential of some community names in preference to others.

9.2.2 Urban Street Classification

1 Urban streets may be classified into one of the following classes:

- (a) Class "A" - Urban Freeway Arterial (a numbered route).
This class may be sub-divided into:

- (i) Class "A1" a dual carriageway freeway, or
- (ii) Class "A2" a single carriageway freeway;
- (b) Class "B1" - Primary Arterial (a numbered route);
- (c) Class "B2" - Secondary Arterial (a numbered route);
- (d) Class "C1" - Tertiary (or Limited) Arterial;
- (e) Class "C2" - Local Collector-distributor Streets;
- (f) Class "D" - Local Streets.

2 The following are functional descriptions of the above classes of street:

- (a) **Urban freeway arterials** are those streets which have a strictly limited number of access points; they have grade separated junctions thereby offering the highest level of mobility (to be signed using blue background freeway signs such streets should be designated as Class "A1" freeways by the provision, at their points of access, of sign R401 - the use of sign R401 carries with it various regulatory requirements controlling the use of freeways in terms of the Road Traffic Act, Act 93 of 1996); although unlikely to occur in urban areas there is a lower order of freeway, classified as Class "A2", which should be designated as such by display of sign R402 - Class "A2" freeways have a single carriageway with no central median, but do have grade-separated junctions - the direction signs for Class "A2" freeways have a green background;
- (b) **Primary arterials** are those at-grade routes for which the most important function is to provide mobility on main through routes for metropolitan or urban traffic not catered for by freeway arterials - these streets will be expected to cater for above average traffic growth and will be numbered routes;
- (c) **Secondary arterials** are those streets which have mobility/accessibility functions which may vary considerably (secondary arterials may include special sub-categories such as "scenic arterials" or "shopping arterials" and are numbered routes);
- (d) **Tertiary (or Limited) arterials** have an above average degree of traffic friction or conflict and are particularly limited in their ability to cater for traffic growth (they are streets from which traffic might be expected to migrate if given a more attractive alternative street or route) - in reality they are commonly unnumbered routes attempting to carry too much traffic for their physical dimensions or frequency of direct access which result in congestion due to high levels of turning movements;
- (e) **Local Collector-distributor streets** are those streets which provide frequent direct access to frontage properties, collect traffic from local streets, and distribute traffic from arterials;
- (f) **Local streets** are those streets which are wholly within a residential, commercial or industrial neighbourhood bounded by arterials and/or local collector-distributor streets - their function is that of local access and they should preferably not be connective.

(continued on page 9.2.5)

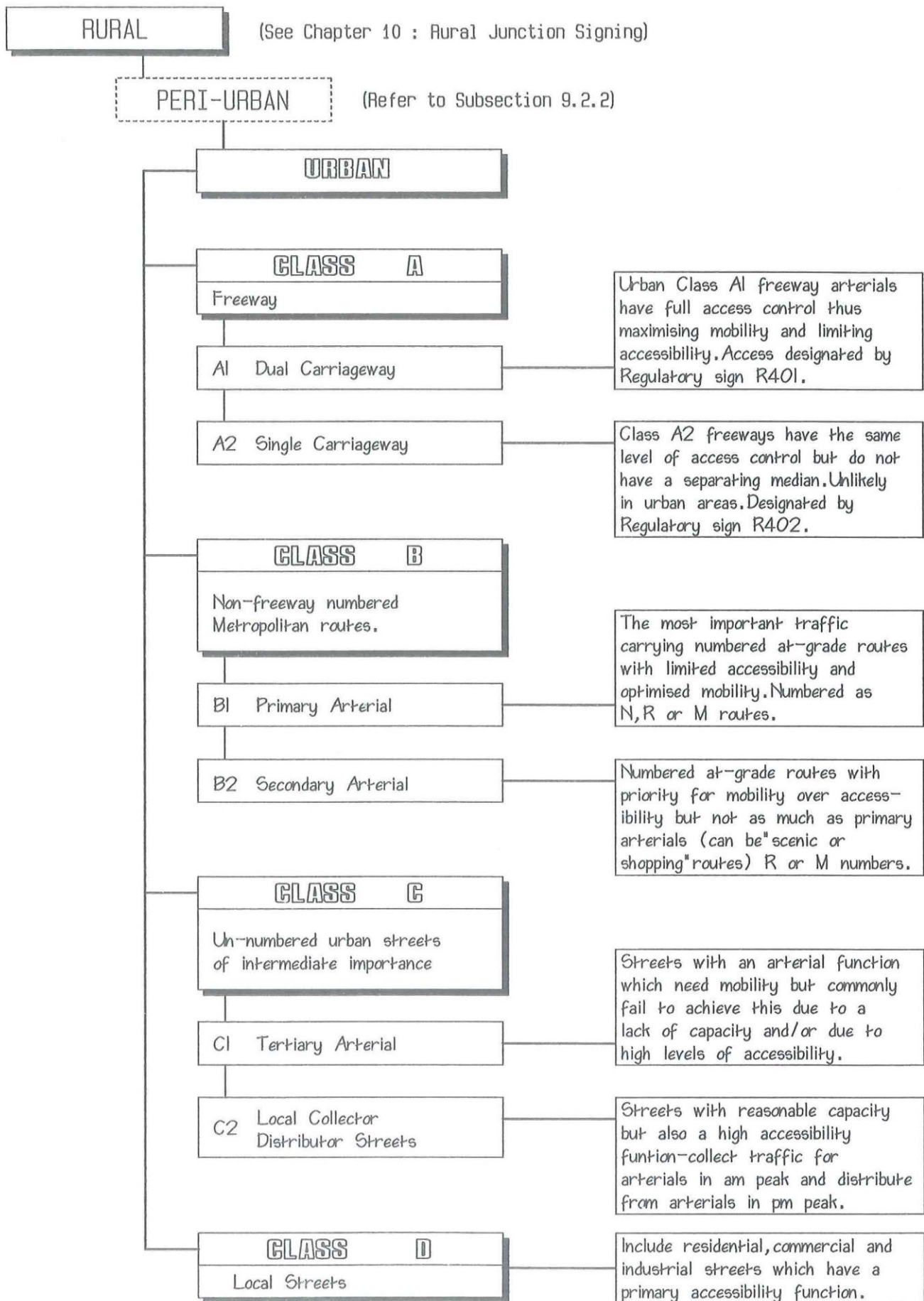

Fig 9.5

Road Classification for Signing Purposes

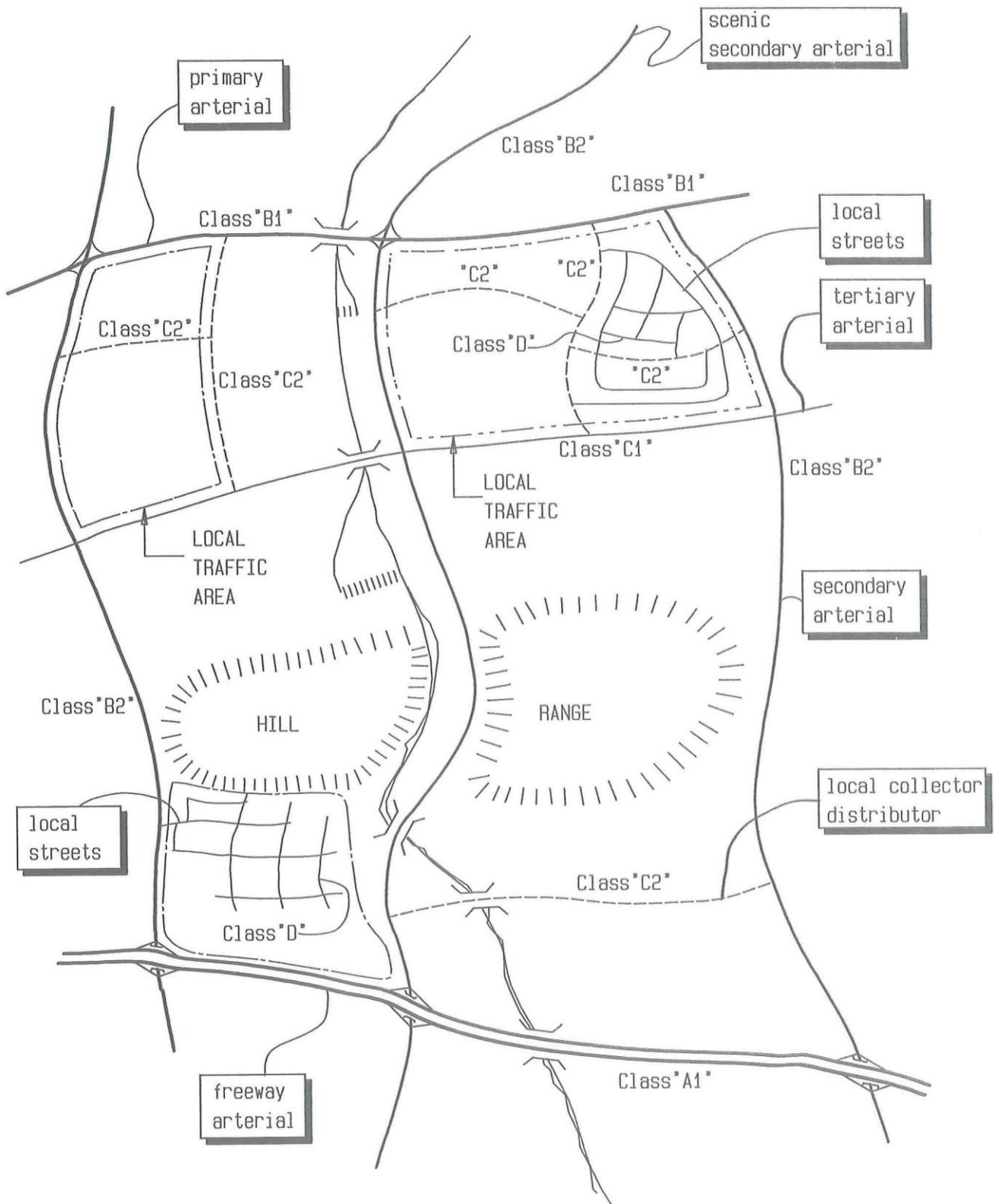
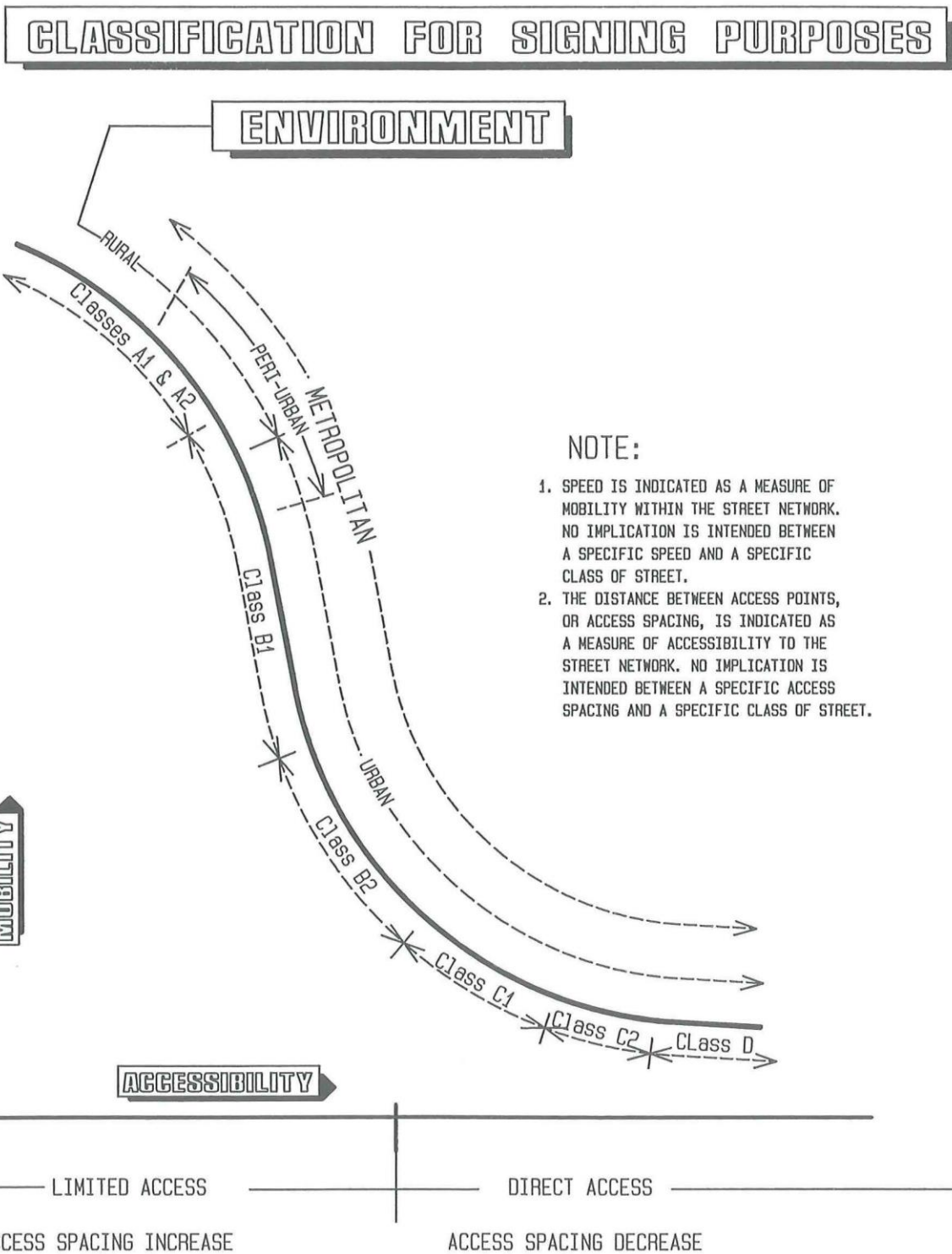

Fig 9.6

Urban Street Hierarchy



Rex

Fig 9.7

Mobility/Accessibility Diagram

(continued from page 9.2.1)

These concepts are illustrated in Figures 9.5, 9.6 and 9.7.

- 3 When direction signs are provided within an urban or metropolitan street network the destinations displayed on signs on the various classes of street will tend to follow a hierarchy which is related to the class of street on which they appear. Thus, if the urban area has sections of freeway arterial, the destinations displayed at this level will normally have an orientational "power" relevant to long-distance provincial or national destinations. If the city or town does not have any freeway arterials the most important primary arterials will display these long-distance provincial or national orientational destinations. Other primary arterials may indicate destinations of regional orientational power. Descending in the street hierarchy to secondary arterials and perhaps the more important tertiary arterials the orientational power of the destinations displayed will diminish. As has been stated above the functions of secondary arterials may vary widely. Similarly the orientational power of any destinations displayed along such routes may vary from places of regional importance, to local suburbs, to simply cardinal directions indicated on route marker signs.

9.2.3 Route Optimisation

- 1 The choice of an optimum urban route can be made by road users out of preference due to their familiarity with the characteristics of the routes on offer, or this choice can be made by the urban authority to strategically attract road users to a preferred route. How effective such a choice will be is dependent on inter-related variables such as the familiarity of the orientation information given, the trip purpose, the perceived time and cost relationships and the type of vehicle. A desire to avoid less attractive or sensitive areas can also influence selection of a route.
- 2 The selection of routes through smaller towns or cities will almost certainly be carried out by provincial or national road authorities as the towns are likely to have grown up around a regional, provincial or national route. As towns develop it will become necessary to establish a broader street hierarchy. At such a time the urban authorities should assess their street network for candidate Class "A", "B1", "B2", "C1" and "C2" streets.
- 3 Once this initial assessment has been made the function of each route should be evaluated in terms of the following criteria to establish the mobility/accessibility characteristics (see also Volume 1, Section 8.3);
 - (a) "familiarity" or trip generating potential of orientation point destinations as indicated by:
 - (i) whether it is a city or town, residential suburb or industrial area;
 - (ii) other local attractor/generator of traffic such as a shopping centre or educational institution;
 - (b) the road type and quality;
 - (c) the trip characteristics such as:
 - (i) traffic volumes;
 - (ii) trip time;

(iii) trip length;

(iv) trips for leisure;

- (d) numbered routes should connect to other numbered routes;
 - (e) numbered routes should not regularly change direction at junctions;
 - (f) numbered routes should not double back, cross themselves or another specific numbered route more than once;
 - (g) an assessment of the accumulated time and cost savings for the majority of road users in comparison to an alternative route.
- 4 The next step in the optimisation process is to actually classify the chosen routes as Class "A", "B1", "B2", "C1" or "C2" as appropriate to their importance, prior to being allocated a route number if classified as Class "B2" or higher.
 - 5 At this stage it is appropriate to consult other interested parties such as road user groups, and road planning and management groups to test the validity of the allocations. These groups should be consulted again during the process of preparing the Urban Guidance Signing Plan (see Section 9.3).

9.2.4 Route Numbering

- 1 It is not appropriate for candidate numbered urban routes to follow the same process used to decide whether a rural route should qualify for a route number. The method of classification described above and the requirement that all Class "A", "B1" and "B2" routes be numbered is adequate.
- 2 The allocation of all urban or metropolitan route numbers shall be co-ordinated with the existing regional, provincial and national numbered route networks to avoid the issuing of conflicting or confusing route numbers in close proximity to each other e.g. R24(provincial) and M24(metropolitan). Care needs to be exercised also when a continuous route passes directly from one metropolitan area to another, or from a metropolitan area into an adjacent provincial region. In cases where the preferred number of an M-route could clash with that of a continuing M-route or a higher order route, the actual route number allocation should be co-ordinated through the Secretary of the Route Numbering and Road Traffic Signs Sub-Committee. It is worthwhile, in a new numbered route network, to establish a basic north-south / east-west order by allocating odd-numbers to north-south routes and even-numbers to east-west routes. (Circular routes can present difficulties in this regard, and also when providing cardinal directions on route marker signs).
- 3 Once route numbers have been allocated, details of the routes and their numbers must be submitted to all map makers and the police, and other emergency services. Any detailed route changes should be passed to emergency services immediately, and to map makers on a two-to-three yearly basis.
- 4 **For numbered route networks to function as intended, it is essential that the relevant road authorities promote the routes, and their numbers, by using all media forms available. Considerable importance is attached to the display of route numbers, to the extent that the level of signing for a numbered route may consist of only route marker signs. Such a choice may be dictated by a lack of space for larger signs, or by economic considerations**

- 5 It is recommended that any local authority using a metropolitan route numbering system (M-routes) for the first time should adopt a unique route marker symbol or shape within the sign (see Volume 1, Chapter 4, Subsection 4.7.11 and Volume 4, Chapter 4). This is particularly relevant when the area abuts another area which is also using numbered metropolitan routes. This shape should be as simple in outline as possible.

9.2.5 Peri-Urban Areas

- 1 Growth of medium to large sized towns, and metropolitan areas, commonly occurs on the outer fringes of the existing developed urban area. This growth is typified by changing land use and by an associated subdivision of land into smaller units. Since the growth will be driven by demand for such land-use change, it is likely to be irregular. Such peri-urban areas have traditionally presented those responsible for the provision of guidance signs with decisions on signing levels and styles which have often proven difficult to make. This decision-making "problem" is commonly made more difficult by the fact that these areas often have a relatively high tourism development.
- 2 A result of the development style of peri-urban areas is commonly higher levels of trips by strangers to the area, than might occur within adjacent or similar urban areas. Due to their lack of familiarity with such an area drivers are likely to need more detailed levels of signing than is normally provided in the rural environment, from which the peri-urban area has developed. This need relates very closely to the more intensely developing road / access network within the peri-urban area. For this reason it is recommended that road authorities responsible for the guidance signing of peri-urban areas adopt urban practices rather than rural practices. The most direct result of such a policy should be the early allocation of street names to the developing road network. In addition consideration of certain areas as high density tourist areas may also be relevant (see Section 9.5).

Reproduced under Government Printer's Authorization No. 11542 dated 7th July 2017

9.3 URBAN GUIDANCE SIGNING

9.3.1 General

1 The first two sections of this chapter have dealt with the available guidance signing tools and the need to approach urban guidance signing in a very structured way. It is very easy for the application of urban guidance signing to become an uncontrolled and ineffective mess of randomly approved, designed, manufactured and installed signs. The emphasis placed on a structured approach is intended to make possible some, or all, of the following:

- (a) the ability of strangers to find their way through, and around, urban areas easily and without stress;
- (b) the ability of urban road authorities to quickly and affordably provide a consistent basic minimum level of guidance signing, if none is currently provided;
- (c) the ability of urban road authorities to develop a long term plan, in consultation with the appropriate role players, for a high quality guidance signing system involving the signs on the ground, adequate records and an effective maintenance system for the signs;
- (d) the assurance that the above objectives can be achieved with an acceptable but minimum intrusion into the urban environment.

2 In this section the principles important to the provision of an effective urban guidance signing system are developed in terms of:

- (a) urban navigation;
- (b) an interim guidance signing plan;
- (c) the different levels of guidance signing which are available;
- (d) an urban guidance signing plan.

9.3.2 Urban Navigation Principles

1 A brief description of two types of trip involving navigation in or through urban areas is given in paragraph 9.1.2.2. Any trip which is deemed to require navigation must involve drivers travelling into areas with which they are not familiar. In the normal course of events daily commuters do not need assistance from guidance signs for their home-to-work trips, relying rather on "landmarks" to navigate their way. (Re-routing as part of an incident detection traffic management scheme will upset this technique because drivers may no longer have their regular landmarks. Such a system may be best served by variable direction signs).

2 The long distance rural aspects of navigation and navigational aids are covered in depth in Volume 1, Chapter 8. In this context many "nodes" or "points" on the rural network are towns which in themselves present navigational challenges which only the very best maps or map-books attempt to include in their navigational information. It is therefore important when considering navigation in urban areas to cater for the long-distance traveller as well as drivers within a major metropolitan environment.

3 The address being sought, when considered in its fullest sense, involves all the components necessary to successfully find it. The full range of components comprising a specific address can be considered as:

- (a) province;
- (b) town;
- (c) route number;
- (d) suburb;
- (e) street name;
- (f) property number.

The provision of urban guidance signs must be designed around these navigational components.

4 The basic navigational difficulties which drivers are most commonly presented with in an urban environment can be described very simply, although they may present themselves in widely differing ways. The following can be considered as the most basic, yet often most difficult, tasks for a driver to undertake in an unfamiliar urban environment:

- (a) finding the specific property which represents the end of a trip whether in a residential suburb, in an industrial area, or in a busy central business district (this can be particularly difficult in a CBD when the organisation sought is one of many tenants in an un-numbered building);
- (b) finding the specific street in which the destination property is located and to turn in the correct direction when street name signs, if they exist, are not located in a consistent position and the letter size used is not adequately legible in the circumstances (this difficulty may of course occur several times during the course of a journey in a large urban or metropolitan area).

It is easy to understand that such difficulties can arise frequently.

5 In addition, during the intermediate levels of a trip, drivers may be navigating using route numbers or familiar destination names. **If these are not signed to match the expectations of drivers, difficulties will occur at this stage of a trip.** Such a problem can occur near the beginning of a trip, at many points along the way, or near the end of the trip in combination with the problems noted in paragraph 9.3.2.4.

6 To minimise the effects of such difficulties the following aspects of the navigation process are particularly important:

- (a) the provision of accurate navigational aids before and during a trip, and
- (b) driver awareness and education of the navigation process so that expectations will tend to match what is provided by the guidance signing system.

7 Navigational aids are available to drivers outside the road environment for trip planning purposes and within the road environment during a trip. The information available can be graded in its importance or effectiveness. Primary information is likely to permit drivers to undertake the majority of their trip and is normally in a very compact form i.e. a route number. At strategic points along the way, secondary information supplements this primary knowledge to assist decisions, normally associated with a change

of direction. Finally a tertiary level of information may be offered, when warranted, to assist drivers in reaching specific types of destination which commonly are larger attractors or generators of traffic than individual private or business premises e.g. meeting venues or tourist attractions. The structure of this information process is illustrated diagrammatically in Figure 9.8.

8 Navigational aids used by drivers during their pre-trip planning, before they commence their journey into an unfamiliar area, may include some or all of:

- (a) road maps, including:
 - (i) inter-town/city maps showing route numbers and destination (town) names, and frequently interchange exit numbers;
 - (ii) large detail town/city maps showing route numbers and street names;
 - (iii) detailed street maps showing route numbers, street names, directions of travel in one way streets, and, if possible, property number sequences (to show the direction of increase and decrease of property numbers);
- (b) road reports;
- (c) other media formats such as brochures, magazines, newspapers, television or videos;
- (d) verbal or written descriptions - which should be transferred to, or correlated with, a road map.

The way in which the information obtained is used is important. It is necessary for drivers to find a suitable way of recording the necessary information. A marked-up copy of the road map will be ideal, whether or not drivers have an assistant "navigator" with them. However, even writing down a consecutive list of route numbers and interchange exit numbers will be very effective for the major part of a long journey.

9 The in-trip navigational aids can include the road maps used in the pre-trip planning and up-dating radio road reports, but the information gained will be confirmed by the information given on the various types of guidance sign provided along the route. The information may comprise:

- (a) route numbers on:
 - (i) route marker and trailblazer signs;
 - (ii) direction and freeway direction signs;
 - (iii) confirmation signs;
- (b) orienting destination names on:
 - (i) direction and freeway direction signs;
 - (ii) confirmation signs;
- (c) local destination names on:
 - (i) town name, suburb name, and street name signs;
 - (ii) local direction signs;
 - (iii) tourism direction signs;
- (d) property numbers and private or commercial property names.

Interchange numbers are commonly provided at the interfaces

between the National route freeway system and lower order urban streets. These numbers are a very valuable navigational aid because the appropriate interchange number may be the only piece of information actually needed to identify the correct exit from the freeway (Class "A") system. It is therefore important that road authorities ensure that information on interchange numbers is made available to map makers and that this information is included on their maps, so that there is the best possible correlation between the maps and the guidance signs used on the road network.

- 10 The various navigational aids referred to in the previous paragraphs can only work if drivers are aware of their existence, and if drivers are aware what information they should obtain from the pre-trip aids. Drivers will therefore also expect, with a good degree of certainty that the same information will also be found on the in-trip aids. Whilst drivers unfamiliar with this process, may not always have their information expectations confirmed by guidance signs, those that are aware of the process, and are educated in its limitations and how it can be made to work, are likely to have expectations which can indeed be matched by guidance signs. **A very important part of the education process involves those who give directions to drivers on to how to reach a specific destination. They also need to know how the navigation system works, so that they give directions in a form that can be matched by expected guidance signs.**

9.3.3 Typical Urban Street Networks

1 The navigational principles described in Subsection 9.3.2 suggest a long distance journey from a large urban area, perhaps passing through smaller urban areas, until ending in another large urban or metropolitan area. Trips within large urban or metropolitan areas, which include areas with which residents are not necessarily familiar, may be carried out, using exactly the same navigating principles.

2 In determining the solution to a problem it is normally beneficial to analyse the nature of the problem. To work effectively urban navigation principles have to be able to work in any type of urban street network. Urban street networks can be categorised as follows;

- (a) **Level 1** - a network of minor streets comprising a town with perhaps one or two "main" streets, none of which warrant classification above Class "C2" (such a description will also commonly apply to suburbs or local traffic areas within larger urban areas);
- (b) **Level 2a** - an essentially similar street network to that in (a) but which may have developed around one or two regional, provincial or national numbered routes whereby there is one junction between such routes and the routes pass through the town without a change of direction;
- (c) **Level 2b** - a street network similar to that described in (b) but where one or both of the numbered routes changes direction within the town;
- (d) **Level 3** - a street network which includes several regional, provincial or national numbered routes - such a network is also likely to include identifiable urban Class "C1" and Class "C2" streets;

(continued on page 9.3.6)

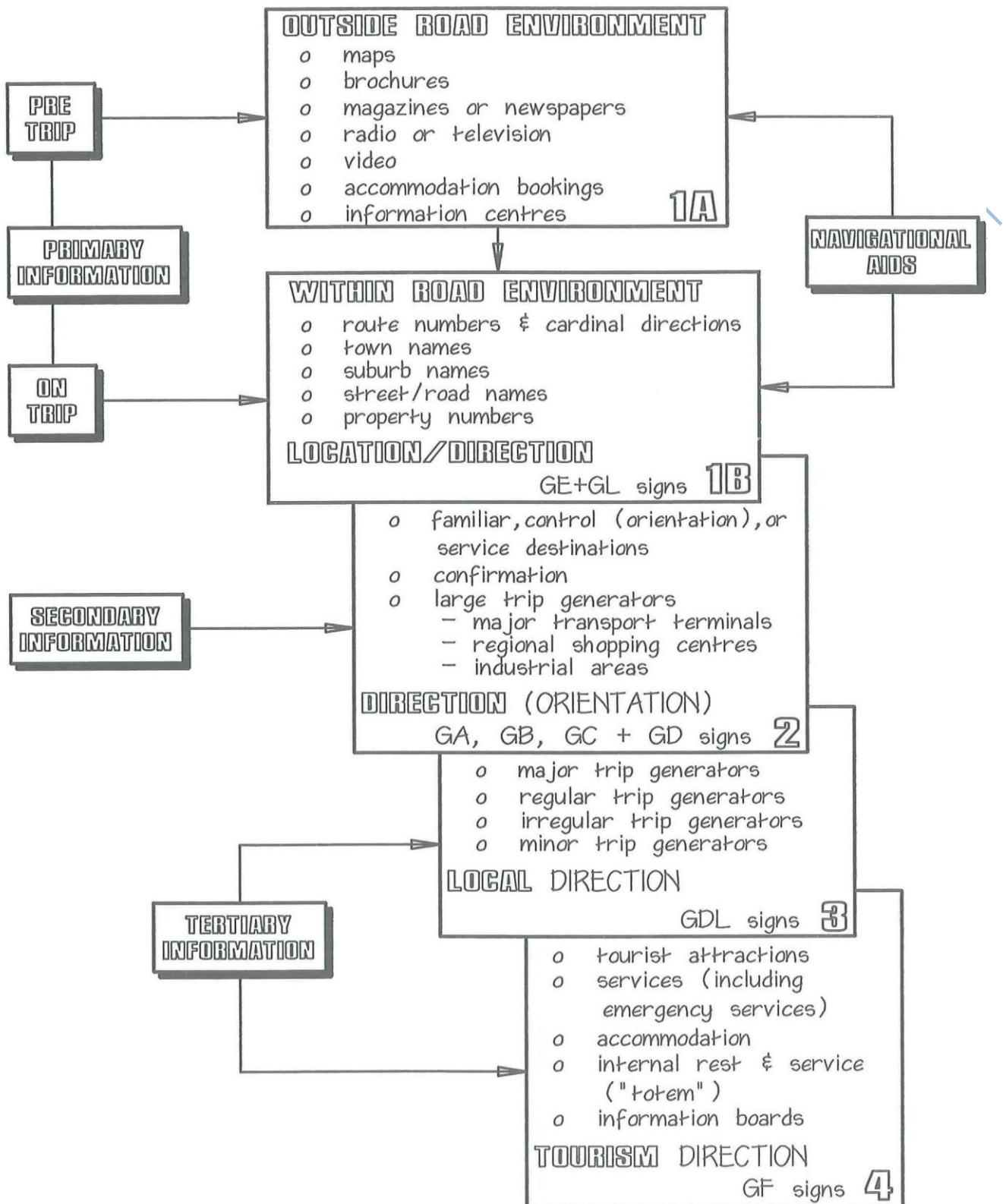

Fig 9.8

Pre-Trip and In-Trip Information Layers

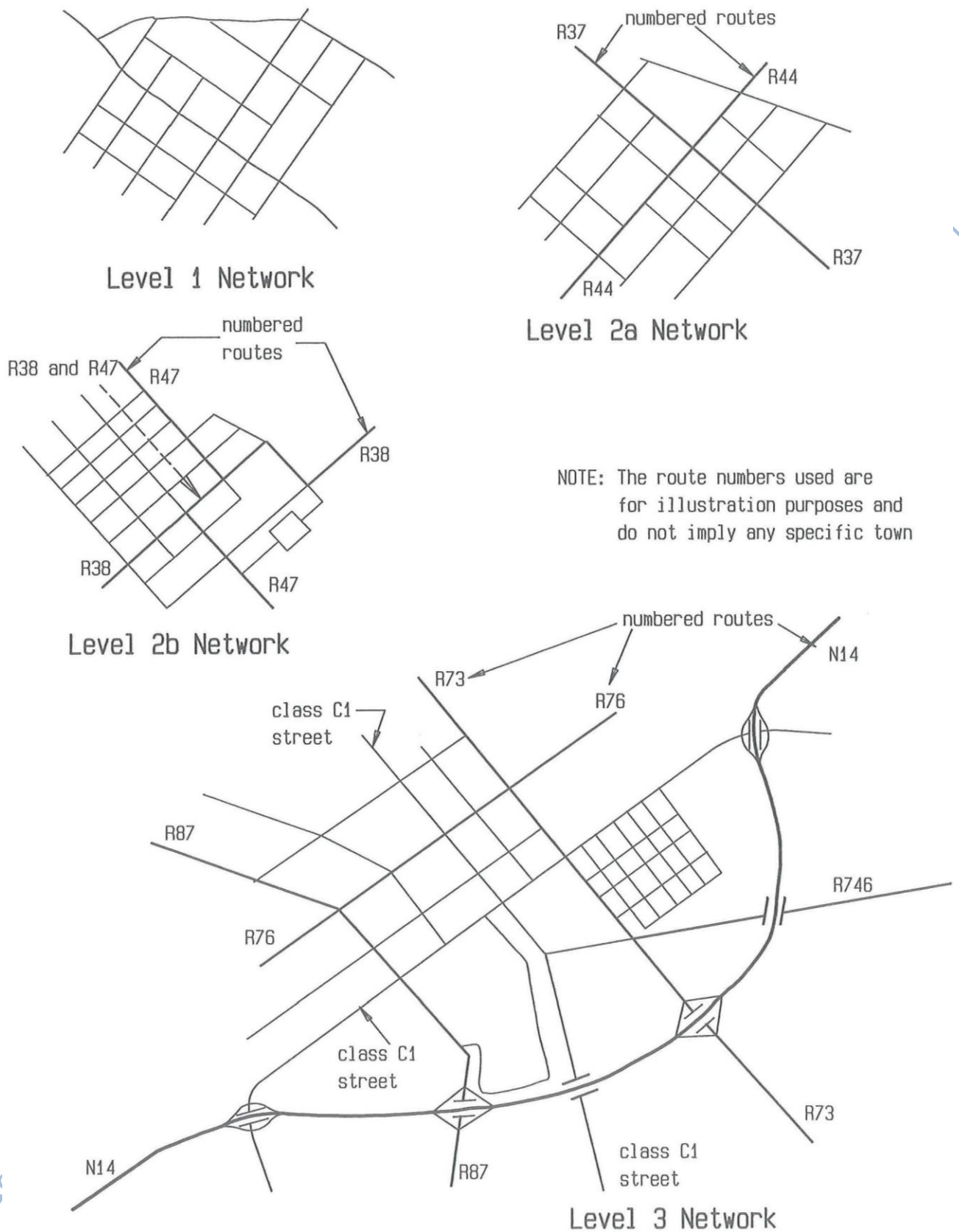
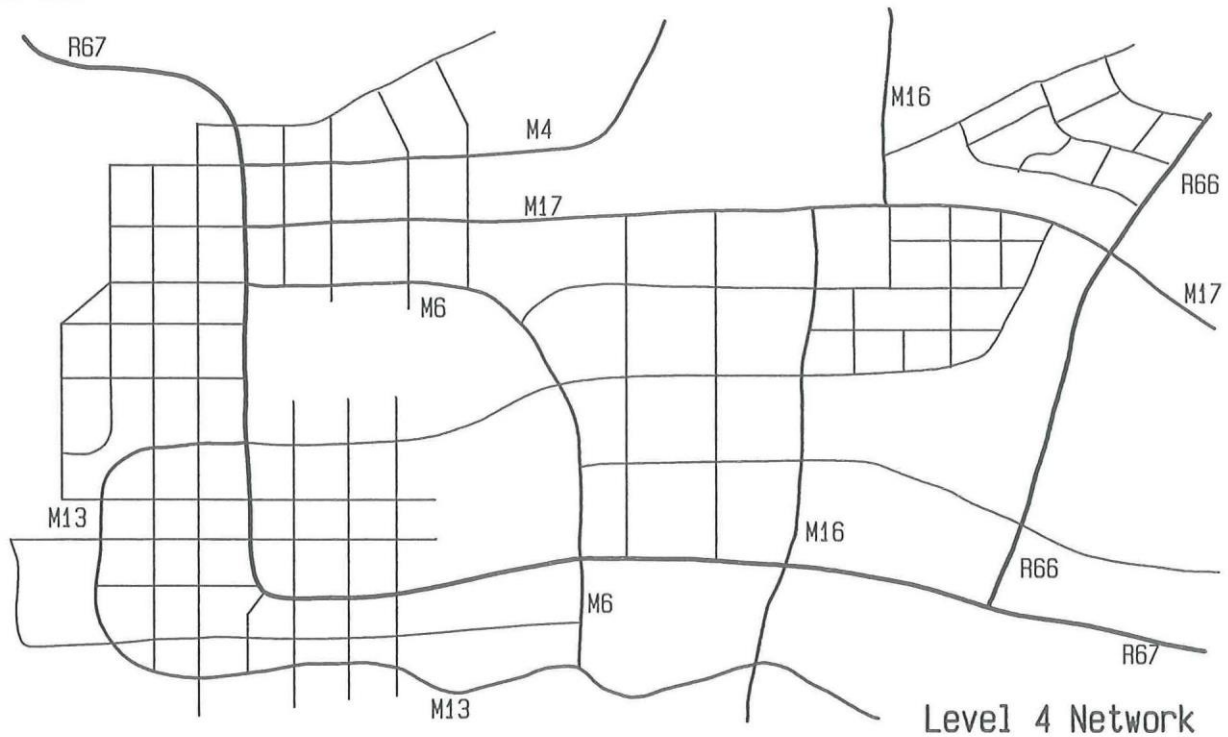

Fig 9.9

Minor Urban Street Networks

12796 A F169-B



NOTE: The route numbers used are for illustration purposes and do not imply any specific town or city.

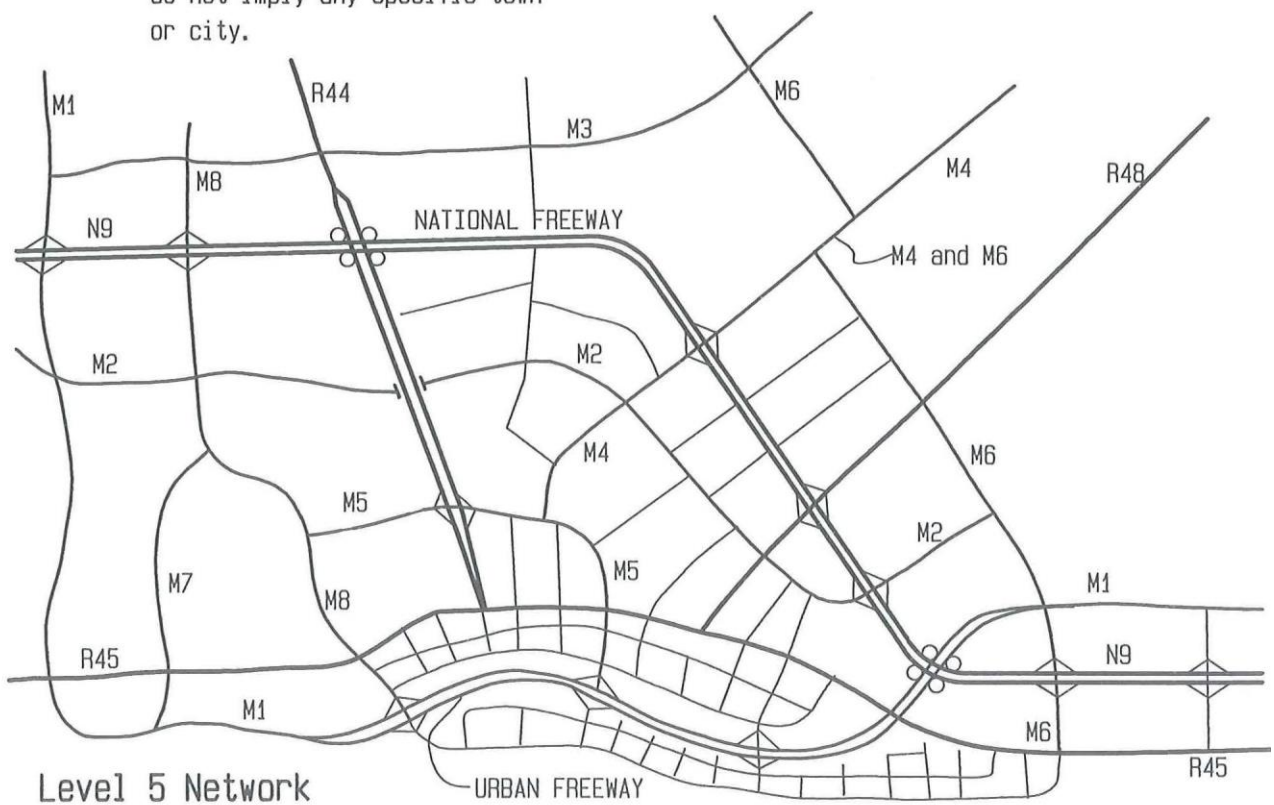

R6

Fig 9.10

Major Urban Street Networks

(continued from page 9.3.2)

- (e) **Level 4** - a street network in which numbered urban Class "B" ("B1" and/or "B2") streets can be identified in addition to regional, provincial or national numbered routes - historically in South Africa such a network has so far only occurred after one, or several contiguous, urban areas have been designated as a metropolitan area;
- (f) **Level 5** - a street network in which the full range of urban street classes, including freeways, can be clearly identified.

Figures 9.9 and 9.10 illustrate this range of typical urban street networks which will all require an urban guidance signing plan of lesser or greater complexity.

- 3 A relatively common South African road network situation involving urban areas is that of the by-pass route. This can occur at any of the levels given in paragraph 9.3.3.2. Figures 9.9 and 9.10 include examples of such situations. The guidance signing of by-passed towns requires particular care and co-ordination between road authorities and is covered in detail in Volume 1, Chapter 8, Subsection 8.6.7.
- 4 Figure 9.11 summarises the type of guidance sign destination message which should normally be displayed on the indicated classes of urban street.

9.3.4 Selection of Destinations

- 1 This Subsection refers specifically to the selection of destination names for use as orientation destinations on Class "A" and Class "B" route direction signs. Local and tourism destination selection is covered in Sections 9.4 and 9.5 respectively.
- 2 The larger an urban area becomes the more difficult it is to adequately select destinations. The selected destinations are likely to work best, however, if the main factor used in their selection is their orientational value or "power".
- 3 After the careful process of route classification, route optimisation and route number allocation has been completed the main objective in selecting the most appropriate destinations is to enable unfamiliar road users to make the correct choices of route, whether this involves a turn to the right or to the left, or a straight-on movement. This applies throughout the various stages of their journey until they reach their final destination.
- 4 The choice of urban destination can be related directly to the level of street network as detailed in paragraph 9.3.3.2. With the exception of a by-pass situation, the destination names which should be selected for any direction signs required in street networks of Levels 1, 2a, 2b or 3 should be the appropriate familiar or control rural destination identified in terms of the provisions of Volume 1, Chapter 8. In a by-pass situation the signing on the by-pass, rather than within the town, will indicate destinations within the town subject to the level of the internal street network. The indication given at access points will normally be as simple as the name of the town if there is no destination beyond the town of any significance. If there are familiar or control destinations beyond the town being by-passed, these should be added to the appropriate direction sign stack, below the town name at the junction concerned.
- 5 In a Level 4 network the principle for Level 1, 2a, 2b and 3

networks will apply to the destinations for direction signs on any provincial or national numbered routes within the urban area. The destinations to be displayed on any direction signs on regional or urban Class "B" numbered routes should be selected after consideration of the following factors:

- (a) the local traffic area or suburb population size (or number of erven) which is likely to offer the best orienting value due to its numerical importance or "power" (if a local traffic area should encompass several suburbs the name to be used to identify the local traffic area as a destination should be either the name of the largest contained suburb or one selected by using of the factors below);
 - (b) traffic composition (with particular emphasis on the percentage of non-commuters if this is likely to exceed the very general rule of thumb of 15% unfamiliar users);
 - (c) trip purpose (this may involve a weighting for seasonal variations in unfamiliar users);
 - (d) the need to avoid less attractive or more sensitive areas;
 - (e) a preference for a destination identified in (a) which is at, or near, the end of the urban route.
- 6 In addition a candidate destination should only be considered if the route runs through it or ends within it. All proposed orientational destination names should be subjected to broad scrutiny including the involvement of local key role-players (see Figure 9.12). **These roleplayers must however be clearly informed on the purpose of the destination names and the limitations applicable in their selection and display. The function of identifying other possible destinations, on the way to the indicated destination, by means of town and suburb name signs should be made clear.** The choice of destination can be weighted because of perceived historical values, but this needs to be considered with circumspection, because it must be determined whether this historical value has merit beyond the immediate local area, in other words to unfamiliar drivers. The preference for "historical" directions tends to lie with, for example, residents giving directions to an in-coming stranger.
 - 7 The availability of supplementary local and tourism signing should be taken into account in the final analysis. It should not normally be necessary to display more than one orienting destination name per exit direction from a Class "B"/Class "B" junction. One exception to this rule should be the inclusion of the names of major traffic generating transport terminals of regional importance.
 - 8 The basis of a Level 5 network should build on that appropriate to a Level 4 network. Class "B1" routes destination names are likely to be the names of the towns making up the metropolitan area or external destinations of provincial or national importance. On Class "B2" routes the names of major suburbs may be used instead of town names, subject to the size of the urban area and the density of the urban route network or the signing may simply consist of the provision of route marker signs (see paragraph 9.2.2.3).
 - 9 The selection of destination names for a Class "A" route within a Level 5 urban street network may present specific problems.

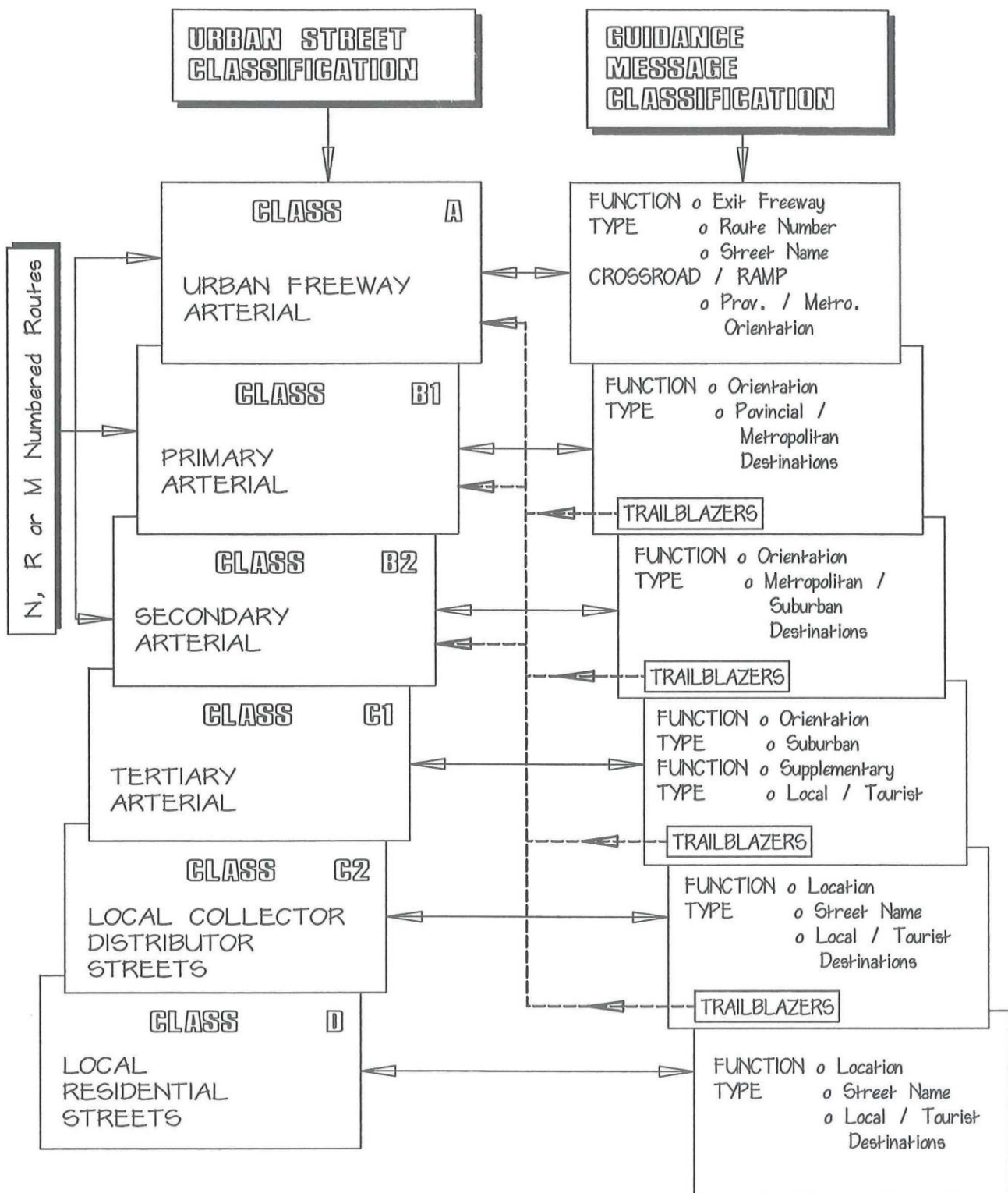
**NOTES:**

- (1) Supplementary local and tourism destination signs may be used on any class of street up to Class "B" subject to warrants and rules (see Volume 2 Chapter 9).
- (2) Supplementary tourism direction signs may also be used on Class "A" roads.
- (3) Trailblazers are used to indicate numbered routes.

Fig 9.11

Urban Street Classification Related to Guidance Message Type

In terms of the approved policy for urban freeway signing given in Volume 1, Chapter 4, Section 4.9 the need for the display of destination names on urban freeway direction signs occurs as follows:

- (a) on confirmation signs - for confirmation;
- (b) on overhead straight-on signs - for confirmation; on exit signs at systems interchanges (normally overhead signs) - for orientation;
- (c) on direction signs on access interchange off-ramps - for orientation when turning onto the cross street;
- (d) on direction signs on the intersecting cross street approaching the freeway - for orientation entering the freeway.

10 The exit direction information given on the freeway up to the point of exit from all urban freeway access interchanges comprises the route number and street name of the intersecting street.

In a peripheral freeway route by-pass situation, the name of a control destination outside the metropolitan area on a regional, provincial or national numbered route may be added. The names of major traffic generators such as transport terminals or large industrial areas may also be added at this level, due to the nature of the traffic generated - i.e. a relatively high percentage of unfamiliar road users, and in the latter case due to the difficulty in manoeuvring heavy vehicles.

- 11 Metropolitan areas, as they grow, tend to incorporate freeway system-to-system interchanges. Such interchanges invariably handle traffic which is partly that generated by a provincial or national network, and partly generated by the metropolitan area. The direction signs at such an interchange should therefore attempt to display orientational destinations which are familiar at the provincial or national level AND those necessary for orientation at the metropolitan level. A detailed example of such a situation is given in Volume 1, Chapter 8, Subsection 8.6.6. Some measure of compromise is almost always necessary due to the limitations on the amount of information and the task complexity experienced by drivers in such situations (see Figure 9.11).**

9.3.5 Preparing an Interim Urban Guidance Signing Plan

- 1** In order to proceed towards the objective of a detailed Urban Guidance Signing Plan it is recommended that urban authorities adopt a structured approach which should use certain basic principles but which may vary in detail according to the size of town and the nature and extent of the street network within the town. The planning process can be conveniently conducted in two parts. **An Interim Plan may be prepared which will not commit the urban authority to detailed sign design but which should establish a complete inventory of the existing signing system and thereby identify the scale of any problem. It will also provide a full road classification for the town.** The complete Urban Guidance Signing Plan can pick up where the Interim Plan stopped and be developed to include an implementation phase with an appropriate budget. The latter should be detailed to the extent that it will include designs for specific urban guidance signs. To these ends a number of procedural steps

are recommended. These are illustrated in Figure 9.12 and are described in the following paragraph.

- 2 The Interim Plan can be considered as a "broad brush" approach to the development of the Urban Guidance Signing Plan involving the first few steps in the overall process. To prepare an Interim Plan the following steps are recommended:
 - (a) **Step 1:** Collect any previous work undertaken by, or for, the authority which in any way impacts on the provision of guidance signs in the town and create an inventory of existing signs and other relevant data. In some instances this may be as little as a record of the allocated street names for a very small town, or a wide range of detailed reports, designs and research on the subject, up to a detailed computer based inventory of existing signs. (It is very likely that any authority which has the latter will already possess an acceptable Urban Guidance Signing Plan and will only need to review and refine if from time to time.) - Figure 9.12 includes a checklist for this process;
 - (b) **Step 2:** Discuss the existing situation with key role-players from the community - these role-players should come from all sectors of the community including the decision makers, those people involved in community affairs and those affected by any actions taken - typically representatives of the business, tourism and public sectors should be involved as well as the emergency services, civil defence and traffic officers;
 - (c) **Step 3:** From the information gained, make an initial assessment of the street network to establish or refine the arterial network including the recording of existing route numbers, if any, and define provisional local traffic areas;
 - (d) **Step 4:** Discuss the initial design with the role-players identified in Step 2;
 - (e) **Step 5:** Review arterial assessment and extend the classification to establish optimum routes and if necessary allocate new route numbers and/or rationalise existing ones, and to identify streets with a collector-distributor function (Class "C2") and thereby determine local traffic neighbourhoods or communities;
 - (f) **Step 6:** Using the criteria given in Subsection 9.3.4 select provisional destination names for the numbered route network on the basis that these must offer the best possible level of orientation for strangers to the area;
 - (g) **Step 7:** Present the details of the Interim Plan, comprising proposed numbered routes and destination names, together with awareness information on the navigational process, to the previously consulted role-players;
 - (h) **Step 8:** Refine the Interim Plan in terms of comments received as a result of the consultation in Step 7 and prepare a written description of all routes.
- 3 Steps 3 and 5 plus the consultative Step 4 result in the creation of a detailed Road Classification for the town or city. Whilst the purpose of this classification is to enable the development of a quality urban guidance signing system it may be of great use for other municipal activities.

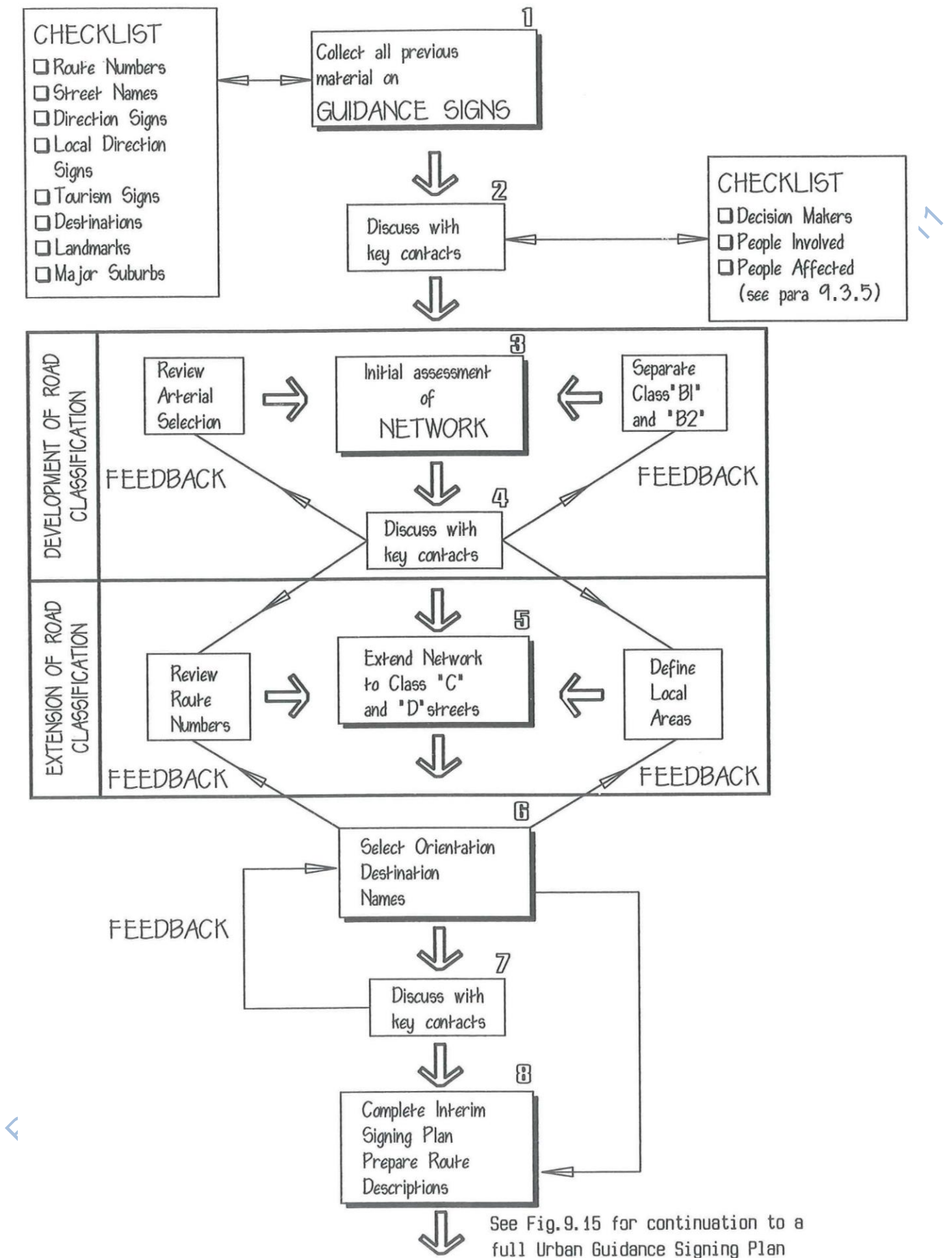

Fig 9.12 Step Process for Interim Guidance Signing Plan

- 4 It is recommended that, subject to the immediate needs of the urban area concerned, the Interim Plan be extended to a full Urban Guidance Signing Plan as described in Subsection 9.3.12.

9.3.6 The "Layer" Approach

- 1 An Interim Plan establishes the route classification and the main orientation destinations for a town or city and records existing signing. In order to implement a cohesive Urban Guidance Signing Plan (see Figure 9.15), it is convenient to consider the information given by the signs as comprising a number of information "layers".
- 2 Figure 9.8 shows three basic layers of guidance information (Layers 1a, 1b and 2) and two optional supplementary layers (Layers 3 and 4) which may be provided subject to various warrants. Layer 1a refers to pre-trip information and, although it must correlate with the on-street information, it is obtained outside the road environment.
- 3 The important on-street layers in this concept are Layers 1b and 2. **Layer 1b must be considered as obligatory, comprising as it does all street name and route number signs and property numbers.** Layer 2 represents a preferred, but often considered unaffordable, level which brings in orientational destinations. There is, however, a range of economic signing compromises between the two basic levels of information described in Layers 1b and 2. These are described in Subsection 9.3.9. The supplementary Layers 3 and 4 are discussed in Sections 9.4 and 9.5 and illustrated in Figure 9.21.

9.3.7 Minimum Urban Guidance Signing

- 1 **If the signing level required by Layer 2, and arrived at in terms of the Interim Plan, is considered unaffordable it is imperative, if urban guidance signing is to be effective at all, that the information required by Layer 1b be provided.** The effect of this requirement is illustrated in Figure 9.13 for towns without numbered routes (network Level 1) and in Figure 9.14 for towns with numbered routes (network Levels 2a, 2b, 3, 4 and 5).
- 2 The example given in Figure 9.13 refers to **the absolute minimum level of urban guidance signing which should be provided by any town.** The example illustrates one street in a Level 1 town, as shown in Figure 9.9 and described in Subsection 9.3.3, and therefore has no numbered routes. The guidance signs which should be provided throughout such a town, as an absolute minimum, are therefore:

- (a) STREET NAME signs GL1 at all junctions, and
- (b) TOWN NAME signs GL3 at all main points of entry into the town, and
- (c) property numbers.

If the town is big enough to have identifiable suburbs SUBURB NAME sign GL2 may be provided as appropriate and CONFIRMATION sign GD3 may be provided at the town limits on any through streets.

- 3 Figure 9.14 shows a typical section of numbered route within a larger town. **In order to provide the minimum acceptable level of guidance under such circumstances the following guidance signs should be provided in addition to property numbers:**

- (a) STREET NAME signs GL1, and
- (b) CONFIRMATION ROUTE MARKER signs GE12 to GE14 as appropriate to the category of route, and
- (c) DIRECTION ROUTE MARKER signs GE12.1/GE12.2 to GE14.1/GE14.2, and
- (d) TOWN NAME signs GL3, and
- (e) SUBURB NAME signs GL2.

In addition CONFIRMATION sign GD3 may be provided at the town limits on numbered streets and ADVANCE DIRECTION ROUTE MARKER signs GE12.3/GE12.4/GS12.5 to GE14.3/-GE14.4/GE14.5 may be provided in advance of a junction between two numbered routes, particularly when right and/or left turn lanes are provided.

- 4 If a town or metropolitan area has prepared an Interim Plan which recommends the provision of one of the identified levels of direction signing, but is unable to implement such a programme of signing within a 12 month period, **it is recommended that the minimum guidance signing illustrated in Figure 9.14 be provided within 12 months.** A co-ordinated programme can then be prepared to provide direction signs to suit the financial resources over a medium to long term (see Subsection 9.3.9).

9.3.8 Discussion on Figure 9.14

- 1 Figure 9.14 illustrates a section of a numbered route which forms part of an urban arterial lying within a Level 2, 3, 4 or 5 network. The fact that the example includes metropolitan "M" routes indicates that it is more representative of a Level 4 or 5 street network **although the minimum guidance signing principles illustrated remain applicable to the lower levels of network, and therefore to the signing of regional, provincial and national roads within such networks.**
- 2 The Class "B" route M44, around which the example is structured, is shown from right-to-left crossing the boundary between two towns "S" and "T" - typical of a metropolitan area. The route also crosses from suburb "Z" in town "S" into, successively, suburbs "Y" and "X" in town "T". At the town and suburb boundaries TOWN NAME sign GL3.1 (with a town crest) and SUBURB NAME sign GL2 are indicated in each direction of travel (only those relevant to travel from right-to-left in the figure are indicated by a sketch of a sign). Where both GL3 and GL2 are called for the GL3 sign precedes the GL2 sign.
- 3 Other class "B" numbered routes, a provincial route R66 and several "M" routes, are shown intersecting route M44. **For each such junction the minimum signing for each approach requires the provision of a STREET NAME sign GL1 and ROUTE MARKER signs GE12.1/12.2 or GE14.1/14.2 as appropriate.** Once again only the route marker signs seen by drivers travelling from right-to-left are illustrated, together with representative signs for other approaches. A ROUTE MARKER confirmation sign GE12 or GE14 should be placed 60 m to 100 m beyond the junction on each numbered route exit.
- 4 **Typical Class "C" streets are also shown intersecting route M44. Crossroads are recommended to have two STREET NAME signs GL1, whereas one such sign should suffice at a T-junction if properly positioned.**

LEVEL 1 NETWORK

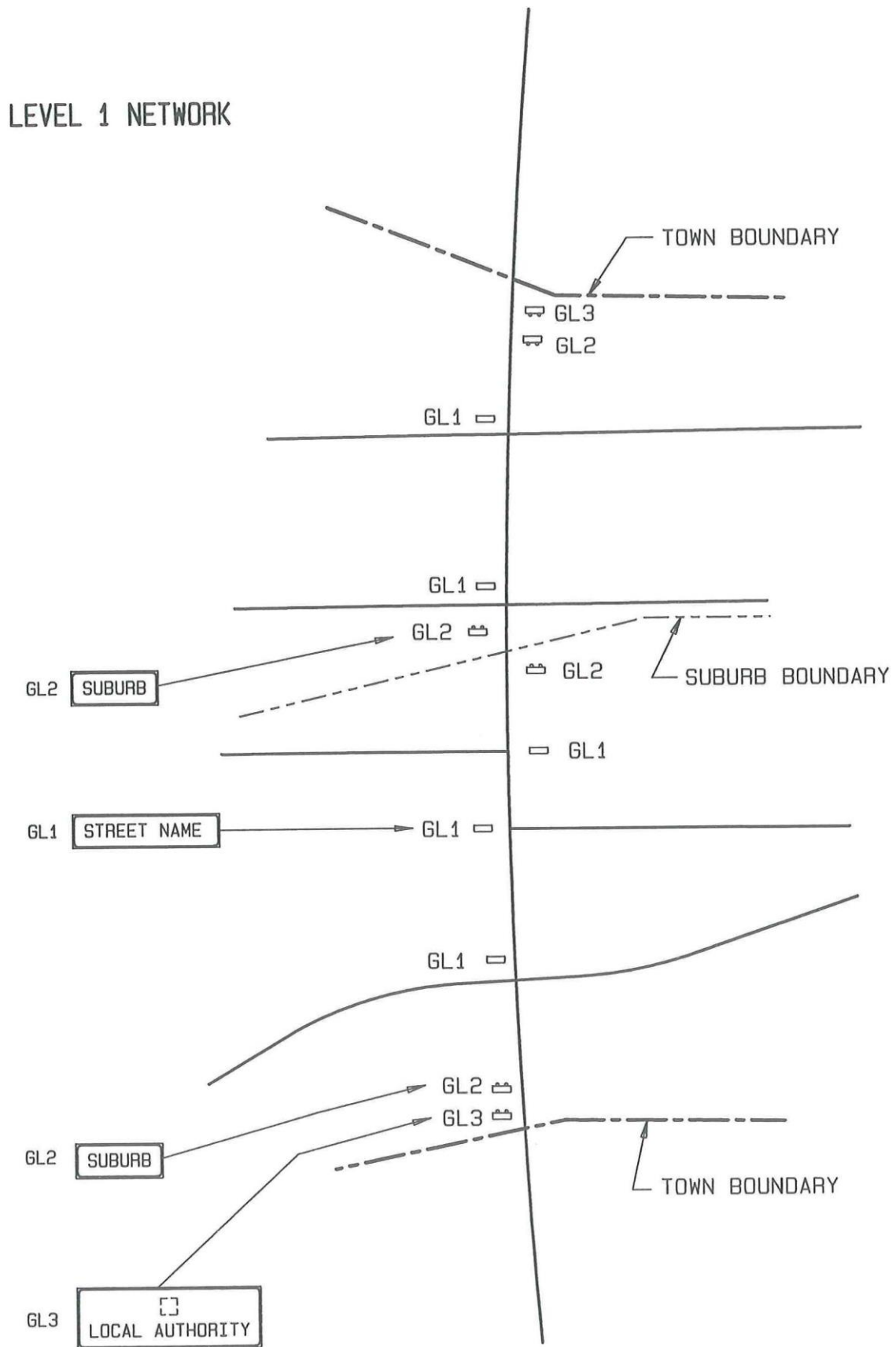

017

Rep.

Fig 9.13

Minimum Urban Guidance Signing -
No Numbered Routes

- 5 All STREET NAME signs GL1 may be double sided and **because route M44 is a numbered route a minimum letter height of 140mm is recommended for all GL1 signs.** Where ROUTE MARKER and STREET NAME signs are used at a junction they should be mounted on common supports or in close proximity to each other so that they lie in a common cone of vision.
- 6 ADVANCE DIRECTION ROUTE MARKER signs GE12.3/12.4 or 12.5 may be specified as an option when turning lanes are provided or sight distance to a junction is poor.
- 7 In urban areas all ROUTE MARKER signs should include a letter representing the appropriate cardinal direction. **When two directions are indicated the right turn sign should always be placed above the left turn sign.**

9.3.9 Selection of Urban Guidance Signing Level

- 1 If a town is in a position to opt for a signing level above the minimum level indicated in Figures 9.13 and 9.14 a range of options is available. The appropriate signing level is not directly related to the class of numbered route, although it is desirable that the higher the class of route the higher should be the level of guidance signing provided.
- 2 Criteria which should, **in addition to cost**, possibly influence the decision as to which level of guidance to adopt, are:
 - (a) traffic volume,
 - (b) percentage of heavy vehicles (obscuration);
 - (c) operating speed of traffic;
 - (d) number of lanes (road width);
 - (e) horizontal and/or vertical alignment;
 - (f) junction geometry;
 - (g) lateral side space (beyond the kerb line or edge of surfacing and up to property boundary);
 - (h) spacing longitudinally of street furniture (including trees);
 - (i) underground services (which might affect sign support location or cost of installation);
 - (j) message continuity;
 - (k) competition from advertising;
 - (l) position of the junction within the urban street network;
 - (m) number of accesses/land use density (trip generation);
 - (n) junction spacing.
- 3 The above criteria may be used in the course of an engineering assessment of the levels of guidance signing appropriate to specific urban street situations. Any such engineering assessment should not be conducted in isolation of the rest of the urban street network so that uniform standards of guidance signing will prevail throughout an area. Figure 9.14 provides a decision chart approach to determining an appropriate guidance signing level according to the identified criteria which may facilitate a relatively quick assessment of a complete urban street network. The signing levels referred to are illustrated in Figures 9.26 to 9.36 In Section 9.8.

- 4 Descriptions of these signing levels are given below where references to classes of urban street are not specific to a particular class i.e. **Class "B" means Class "B1" or Class "B2"** as appropriate to the criteria for specific streets of both classes:
 - (a) Level OA-S - Overhead Systems Interchange Level
Level OA-A - Overhead Access Interchange Level
Level 1A-A - Access Interchange Level
Level 1A-C - Preferred Class "A" Crossroad Level
Level 2A-C - Minimum Class "A" Crossroad Level;
 - (b) Level 1B - Preferred Class "B" Level
Level 2B - Intermediate Class "B" Level 1
Level 3B - Intermediate Class "B" Level 2
Level 4B - Minimum Class "B" Level;
 - (c) Level 1C - Enhanced Class "C" Level
Level 2C - Minimum Class "C" Level;
 - (d) Level 1D - Enhanced Class "D" Level
Level 2D - Minimum Class "D" Level.

9.3.10 Discussion on Figure 9.15

- 1 Many factors are involved in the decision making process for the selection of a suitable level of urban guidance signing. The more important of these factors are listed in Subsection 9.3.9. In order to make a detailed assessment involving so many factors, an engineering analysis of some complexity is required. Most authorities are not prepared, or able, to commit the resources needed to do such an analysis.
 - 2 Figure 9.15 has been prepared to provide a quick analysis using the majority of the identified factors. Each section of the figure is numbered for reference purposes - the numbers are not always in a working sequence because several sequences are possible.
 - 3 The figure works on a "yes"/"no" answer basis to stated questions. The outcome of box "1" will decide whether the process continues or whether in fact an engineering assessment really is required (see box "12").
 - 4 The junction configuration requires the selection, in box "2", of a class of junction approach. For Class "B" routes, this leads to an assessment of the "Level of Service" of the route using box "3". The levels indicated can be considered as similar to the normal AASHTO grading. Speed, % of heavy vehicles and traffic volume are **assessed** on a "Low/Medium/High" basis and scores are added and recorded. The score correlates with a typical AASHTO level of service in a range from "A" to "F".
 - 5 Proceeding with the analysis, boxes "4" to "7" relate to the physical characteristics of the junction approach. Alternatively if a Class "A" route is being assessed boxes "8" and "9" are used.
 - 6 Block "11" indicates a level of signing which correlates with the levels illustrated in the figures given in Section 9.6. **Affordability of a particular level will always be in question.**
 - 7 Subsection 9.3.11 deals with representative examples of the use of Figure 9.15.
- (continued on page 9.3.14)

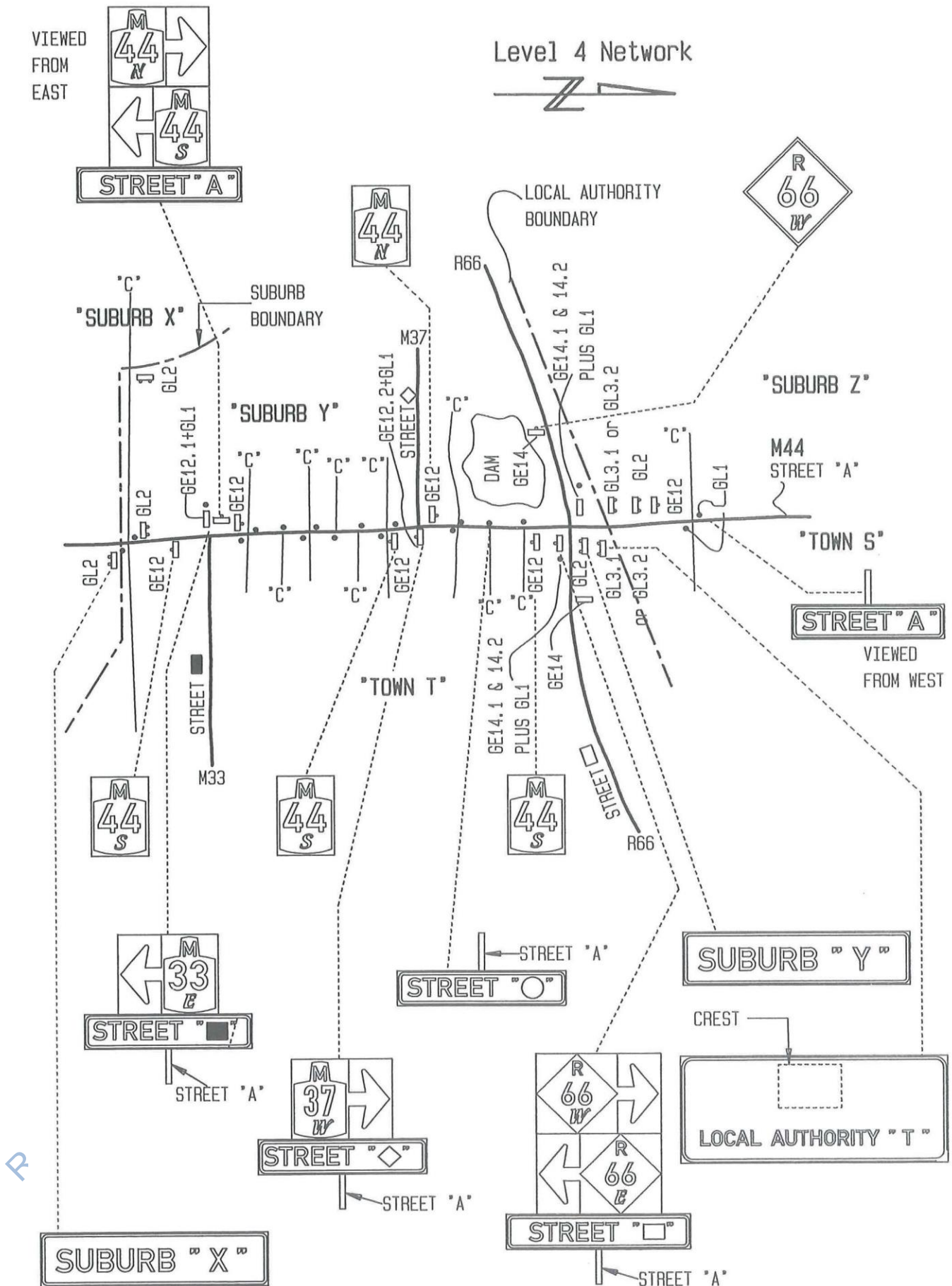

Fig 9.14 Minimum Urban Guidance Signing - Numbered Routes

9.3.11 Worked Examples for Figure 9.15

The following examples are typical of urban street situations which may occur during the course of an assessment of an urban street network in terms of an Urban Guidance Signing Plan.

Example 1: Class "B1" Street Approach

Existing conditions:

- the junction is between two metropolitan Class "B" routes;
- the level of service is not known;
- traffic volumes are high;
- the route is a bus route and otherwise carries an average percentage of heavy vehicles;
- average approach speeds are slightly below the speed limit;
- two through lanes on the approach;
- the junction is 400 m from the nearest junction and 1600 m from the nearest previous Class "B" junction.
- space on the approach is limited due to closely spaced trees and street light poles;
- the junction area itself is open.

In addition it has been determined that:

- if direction signs are used message continuity can be maintained;
- underground services are not a problem;
- there are no advertisements;
- the approach is straight and even graded slightly uphill;
- junction geometry is straight forward.

The Decision Chart in Figure 9.15 can now be used. As a result of the given conditions we can move from Box 1 to Box 2 and choose the B/B box. Since the level of service of the approach is not known we work through Box 3. In this case the "Scores" from the three internal blocks of Box 3 will be:

- traffic volume = 1;
- % heavy vehicles = 2;
- speed = 2;

giving a total score = 5.

The level of service is therefore equivalent to Level D. Proceeding to Box 4 there are less than three lanes on the approach so we go on to Box 5. The nearest junction is not close so we can move to Box 6. Since the space on the approach is limited we move to Signing Level 2B in Box 11.

Level 2B represents the Intermediate Level 1 signing level for Class "B" and comprises the following sign sequence (see Figure 9.50):

- GE12.3/GE12.4 - ADVANCE DIRECTION ROUTE MARKER signs;
- GD2 - DIRECTION sign (including the street name).

Example 2: Class "C" Street Approach

Existing conditions:

- the junction is between a tertiary arterial collector-distributor Class "C" street and a Class "B" route;
- the junction is signalised;
- the street is a two lane two way street with no turning lanes;
- the street is tree lined with street lighting poles on the left side.

In addition it has been determined that:

- if direction signs are used message continuity can be maintained;
- underground services are not a problem;
- there are no advertisements;
- the approach is straight and even graded slightly uphill;
- junction geometry is straight forward.

The decision Chart in Figure 9.15 in this case takes us to the C/B block of Box 2. The level of signing for this class of street does not include direction signs so we move straight to Boxes 10 and 11. For Class "C" streets we have a choice of Levels 1C or 2C - see Figure 9.53. Because the route intersects a Class "B" route the Enhanced 1C signing level is recommended. Standard signs are:

- GE12.1/GE12.2 - DIRECTION ROUTE MARKER signs
- GL1 - STREET NAME signs.

Example 3: Class "B2" Approach to A Freeway

- the freeway has been trailblazed for some distance;
- neither services nor advertisements are a problem.

The Decision Chart in Figure 9.15 again leads us to Box 2 and to the one class B/A box. Since the signing level of a B/A approach can only be varied due to a limited space, this box leads directly to Box 8 where the choice is between Signing Levels 1A-C or 2A-C. In this case Level 2A-C is a likely option (see Figure 9.48).

9.3.12 The Urban Guidance Signing Plan

1 The steps involved in preparing an Interim Guidance Signing Plan for an urban area are described in Subsection 9.3.5 and are illustrated in Figure 9.12. This Interim Plan comprises three main components:

- (a) numbered routes;
- (b) selected orientation destinations;
- (c) an inventory of existing guidance signs.

2 To extend the Interim Plan to an Urban Guidance Signing Plan the following steps, which are illustrated in Figure 9.16, should be carried out after the completion of Step 8 of the Interim Plan:

- (a) **Step 9:** Record all existing street names, assess any confusing combinations of names at junctions with due consideration to re-naming if necessary, and allocate names to any streets that are unnamed. Record at least the property numbers at the end of

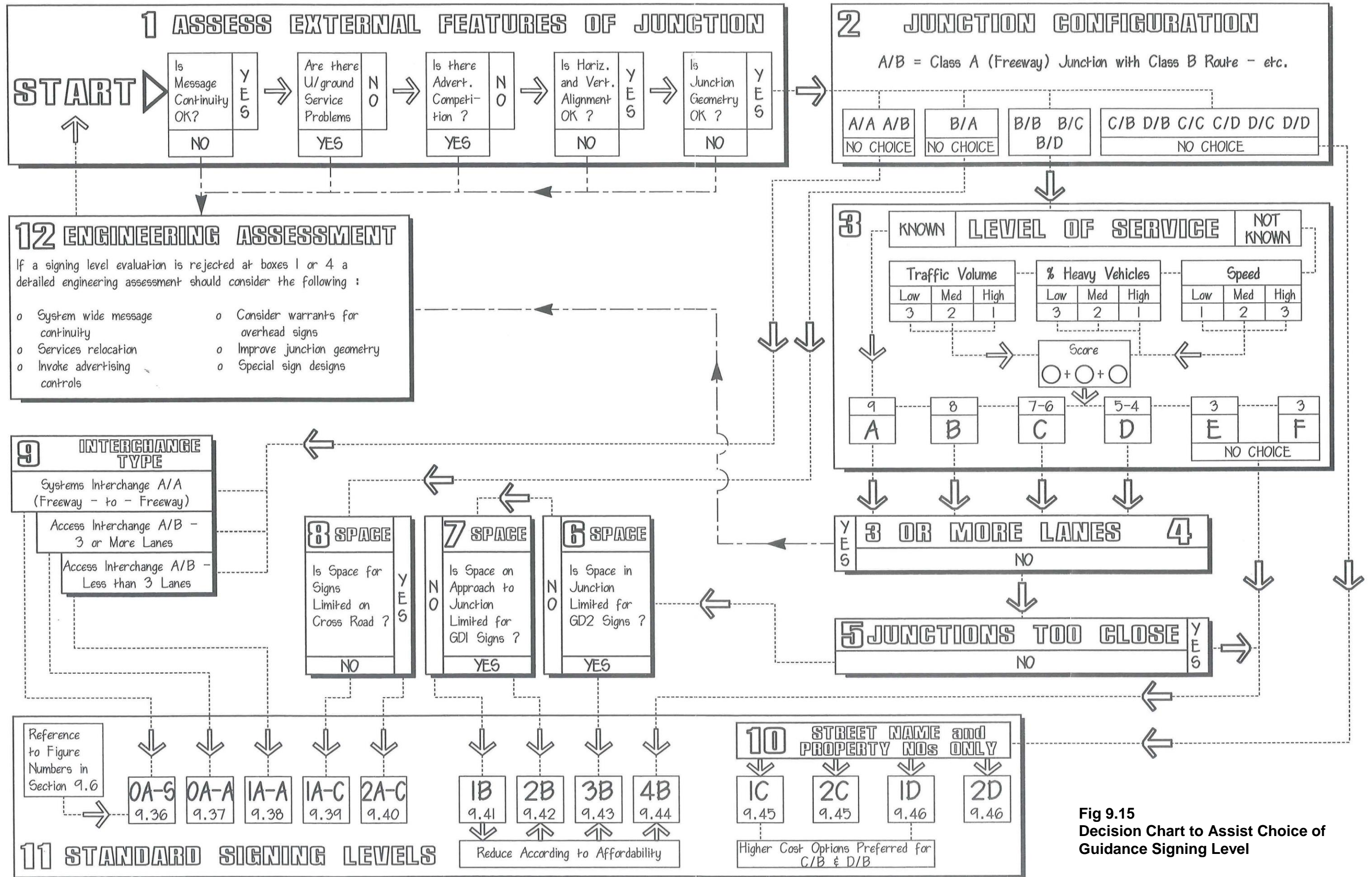

Fig 9.15
 Decision Chart to Assist Choice of Guidance Signing Level

each block between intersections, so that the direction of increase or decrease in property numbering is available for inclusion on STREET NAME (GL1) signs, if required.

- (b) **Step 10:** Assess the need in the area for at least Group 3A local destinations (see Table 9.1), according to relevant warrants, and record the junctions at which local direction signs will be required. According to the requirements of the urban authority, this process can be continued proactively for Groups 3B, 3C and 3D local destinations. **The priority should be to first identify the local signing needs at junctions at which standard direction signs are likely to be provided, in order that the areas of greatest information pressure for drivers can be subjected to engineering assessment if necessary.** A similar process should be carried out for the tourist destination types listed in Groups 4A to 4D (see Table 9.2).
- (c) **Step 11:** For each junction in the network, on Class "A" and "B" routes, survey the relevant criteria and determine the appropriate level of guidance sign for each approach to such junctions (see Subsection 9.3.9 and Figure 9.15). Once this information is obtained record the sign types required appropriate to the chosen level of signing.
- (d) **Step 12:** Re-assess the first allocation of guidance signs from Steps 10 and 11 to eliminate any sequential inconsistencies along specific routes e.g. frequent changes in signing level from one junction to another, either upwards or downwards in level. This reassessment should take into account the actual ability to upgrade lower levels of signing at isolated junctions, in terms of certain criteria e.g. the space available for signs. If necessary the reassessment should involve the downgrading of some chosen signing levels to achieve a reasonably consistent level of signing along the route. **During this process all junctions which will be provided with a DIRECTION sign GD2, incorporating the intersecting street name, should be recorded and the requirement for a stand-alone STREET NAME sign GL1 in such a position deleted appropriately.**
- (e) **Step 13:** Add the local and tourist direction sign requirements identified in Step 10 and adjust the positions of any ADVANCE DIRECTION signs GD1 to allow all drivers sufficient reading time for all signs provided, OR identify options to establish information laybys and/or centres (see Sections 9.4 and 9.5).
- (f) **Step 14:** At this stage the details of the plan should now be submitted to the key role players identified during the Interim Plan phase. Details of the Plan should be adjusted as necessary.
- (g) **Step 15:** Carry out the signface design for all guidance sign types (see the checklist in Figure 9.16), allocate accurate positions for all signs and record these details for each sign. Record sign area quantities for budgetary purposes and prepare a local system design for each junction (see Subsections 9.3.15 and 9.3.16).
- (h) **Step 16:** Compare the design output from Step 15 with the

inventory established in Step 1 and **identify existing signs which are outdated or redundant.** Adjust the budget input for any resultant sign removal or redesign.

- (i) **Step 17:** Prepare a budget and implementation programme for the Urban Guidance Signing Plan.

9.3.13 Minimum Requirement - Short Term Plan

- When the final Urban Guidance Signing Plan is completed, and the implementation plan in terms of available finances has been prepared, the time frame for this will become evident. If it is not possible to budget to achieve the ultimate level of the Plan within two years **it is highly recommended that a minimum implementation plan be prepared which should be carried out within twelve months so that an effective guidance sign navigation system can be in place as soon as possible to minimise the risk of drivers losing their way.**
- The signing required to complete a minimum implementation plan is as follows:
 - for a Level 1 network - provision of all STREET NAME (GL1) signs;
 - for all other levels of urban street network - provide all STREET NAME (GL1) signs and for all numbered routes CONFIRMATION ROUTE MARKER (GE12) and DIRECTION ROUTE MARKER (GE12.1/GE12.2) signs with an option to provide strategic ADVANCE DIRECTION ROUTE MARKER (GE12.3/GE12.4/GE12.5) signs when sight distance to the junction is limited.

9.3.14 Medium to Long Term Plan

- In conjunction with a minimum requirement short term plan, and any street development and major rehabilitation programmes, a medium to long term plan to implement the balance of the system of orientational direction signs should be prepared, so that the provision of such signs, beyond the minimum plan, can be budgeted for at an affordable rate. Such a medium to long term plan should also take note of the local and tourist direction sign requirements. **A particular aspect of this phase of the work should be the co-ordination of the plan with signs provided in terms of new development, and individual applications, so that, as far as possible, inconsistencies in information display along a route are eliminated.**

9.3.15 Detail Sign Design

- Detailed signface design can be carried out for the full Plan once it is finalised, or in phases as dictated by budget and design resources.
- In addition to the design of each signface in the system, a local system design should be undertaken for each junction. This should include the following detail:
 - allocation of a unique junction reference number which should be co-ordinated with any existing accident record inventory system;
 - signface designs with full dimensional details for all signs required at the junction - each sign to be allocated a unique identity number;

From Fig.9.12 Step 8

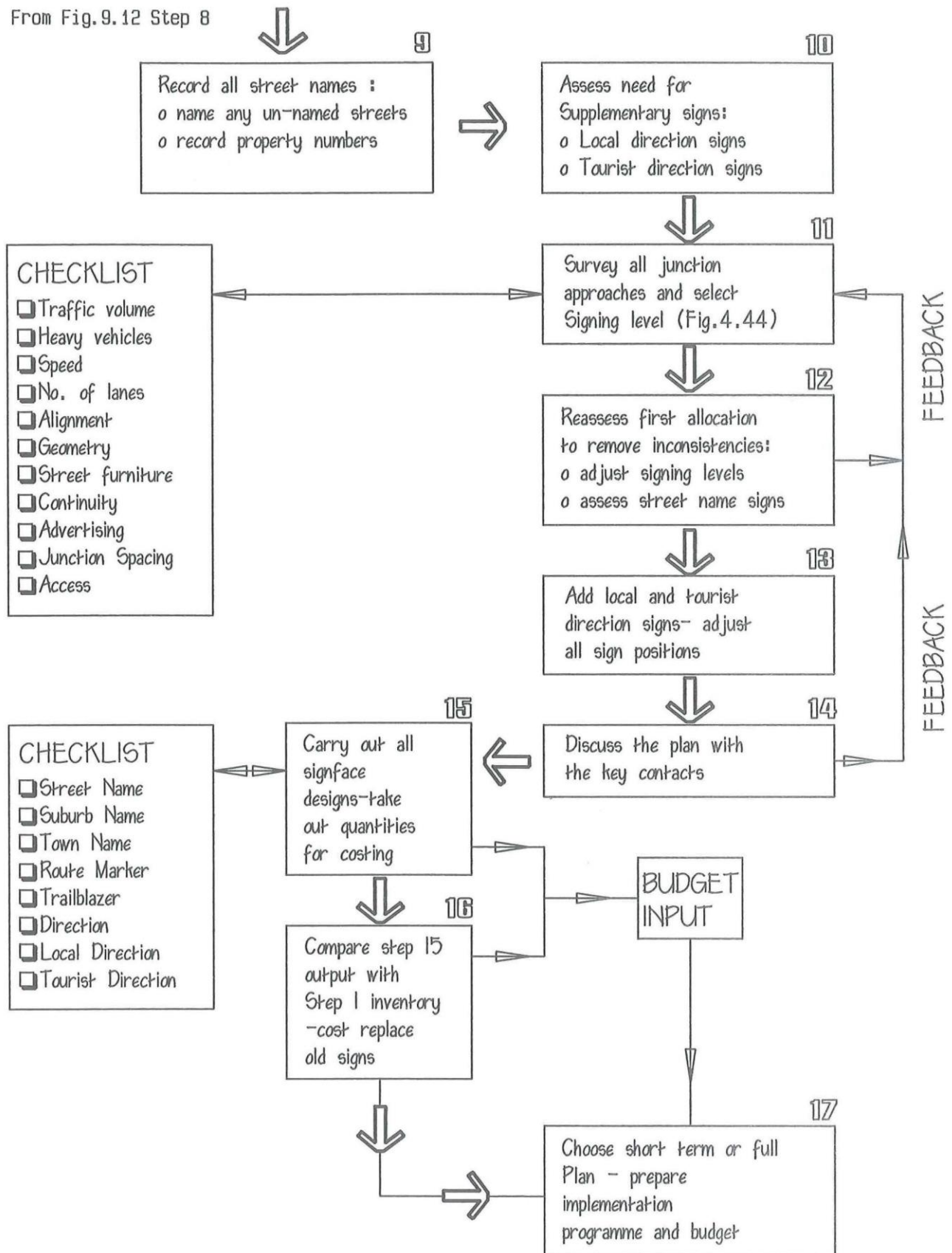

Re.

Fig 9.16

Step Process to an Urban Guidance Signing Plan

- (c) a schedule of sign areas;
 - (d) signface material requirements;
 - (e) precise sign positions with locating diagrams;
 - (f) cost estimates with an indication of responsibility for payment or source of funding and its availability;
 - (g) a priority listing allocation for implementation;
 - (h) a record of any unusual requirements e.g. overhead mounting, part of a street construction scheme, illumination, conflict with other services etc.
- 3 New sign designs can be recorded directly into a sign management database for future reference. Such a database should be updated to include all signs which existed prior to the preparation of the Urban Guidance Signing Plan.

9.3.16 Sign Maintenance Management Plan

- 1 As soon as any phase of the Urban Guidance Signing Plan is implemented a sign maintenance management plan should be set up. Limited guidelines for such a maintenance plan are given in Volume 1, Chapter 1 and more complete details are covered in Chapter 16 of this Volume.

Reproduced under Government Printers Authorization No. 11542 dated 7th July 2017

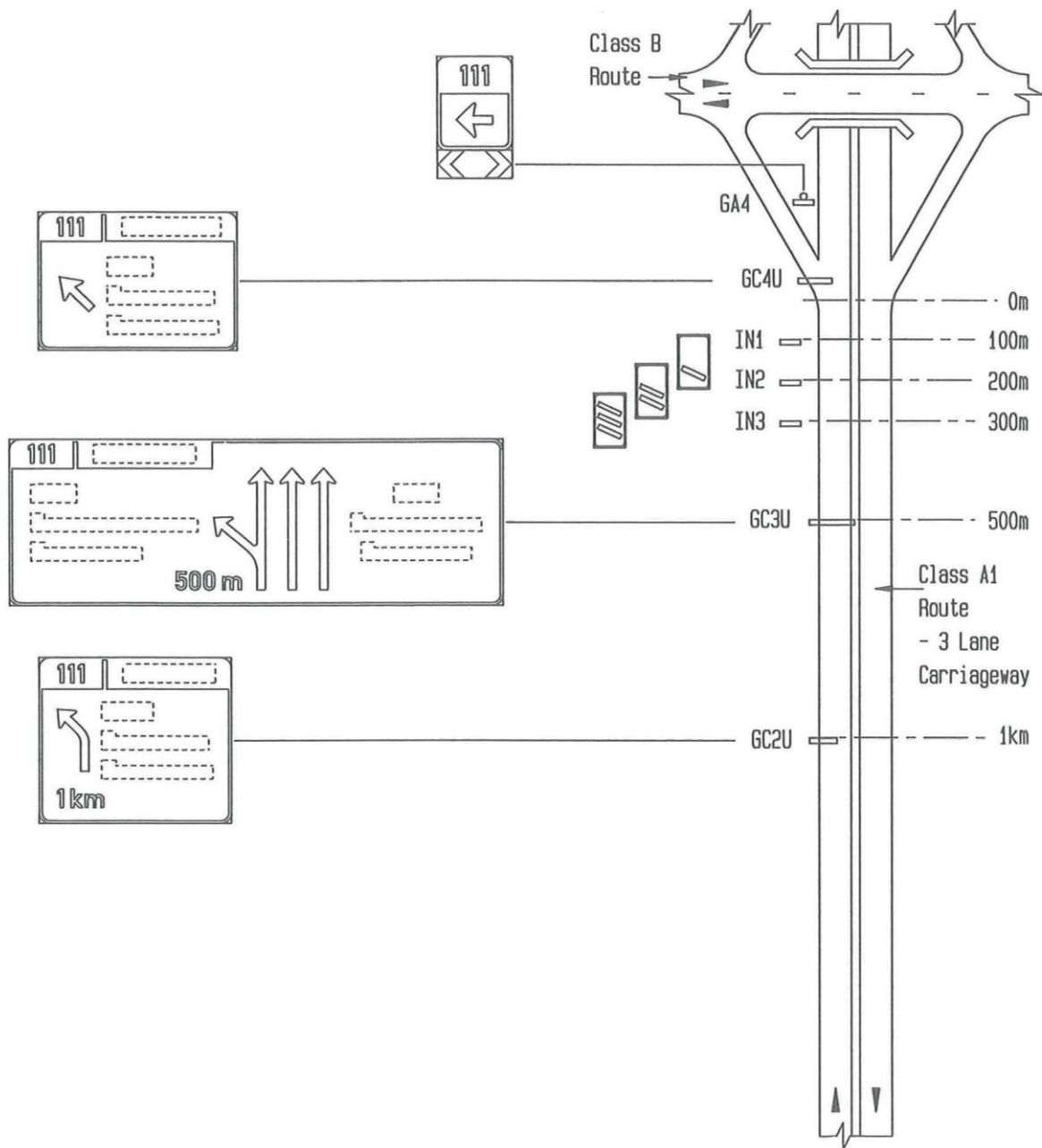

NOTES:

- (1) Figure 9.17 shows the basic guidance sign sequence applicable to an urban Class A1 freeway at an access interchange when the freeway carriageways have 3 or more lanes. A number of additional FREEWAY DIRECTION signs may be used to supplement this basic display. For further details see Figures 9.44 to 9.48 in Section 9.6.
- (2) Warrants for the use of overhead FREEWAY DIRECTION signs are described in Subsection 9.6.9.
- (3) The function and application details of urban overhead FREEWAY DIRECTION signs are described in full in Volume 1, Chapter 4, Sections 4.1, 4.2 and 4.9.
- (4) For dimensional details see Volume 4, Chapter 6.

Rf

Fig 9.17

**Basic Urban Guidance Signing Sequence – Freeway Class A1
Access Interchange – 3 Lane Carriageway**

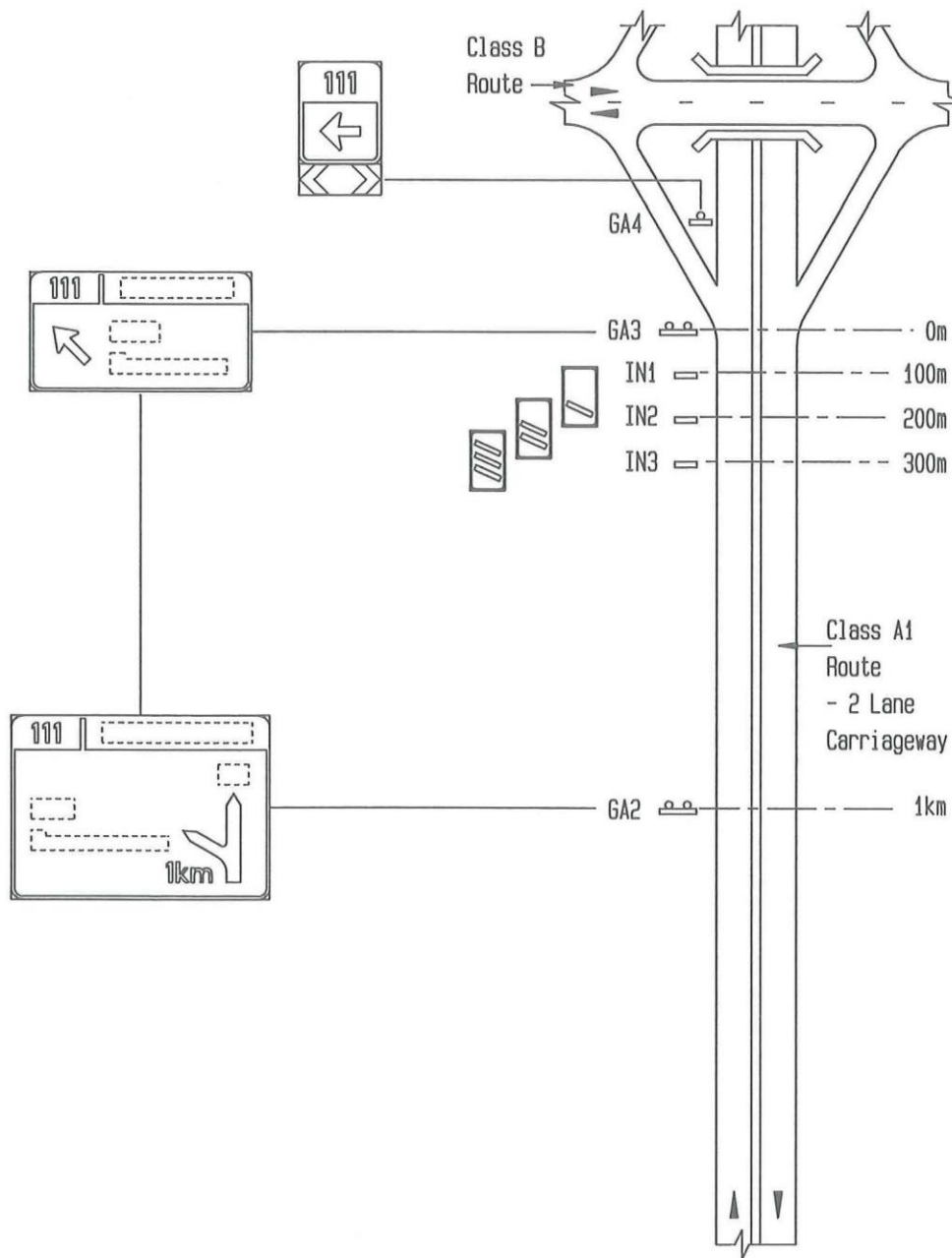

NOTES:

- (1) Figure 9.18 shows the basic guidance sign sequence applicable to an urban Class A1 freeway at an access interchange when the freeway carriageways have 2 lanes. A number of additional ground-mounted FREEWAY DIRECTION signs may be used to supplement this basic sequence. For further details see Figures 9.44 to 9.48 in Section 9.6.
- (2) The function and application details of urban overhead FREEWAY DIRECTION signs are described in full in Volume 1, Chapter 4, Section 4.1, 4.2 and 4.9. For dimensional details see Volume 4, Chapter 6.
- (3) For dimensional details see Volume 4, Chapter 6.
- (4) This same basic sign sequence is appropriate for an urban Class 2 freeway (only one carriageway with no median island). For a Class A2 freeway application the signface background colour is changed from blue to green.

Fig 9.18 Basic Urban Guidance Signing Sequence – Freeway Class A1 Access Interchange – 2 Lane Carriageway

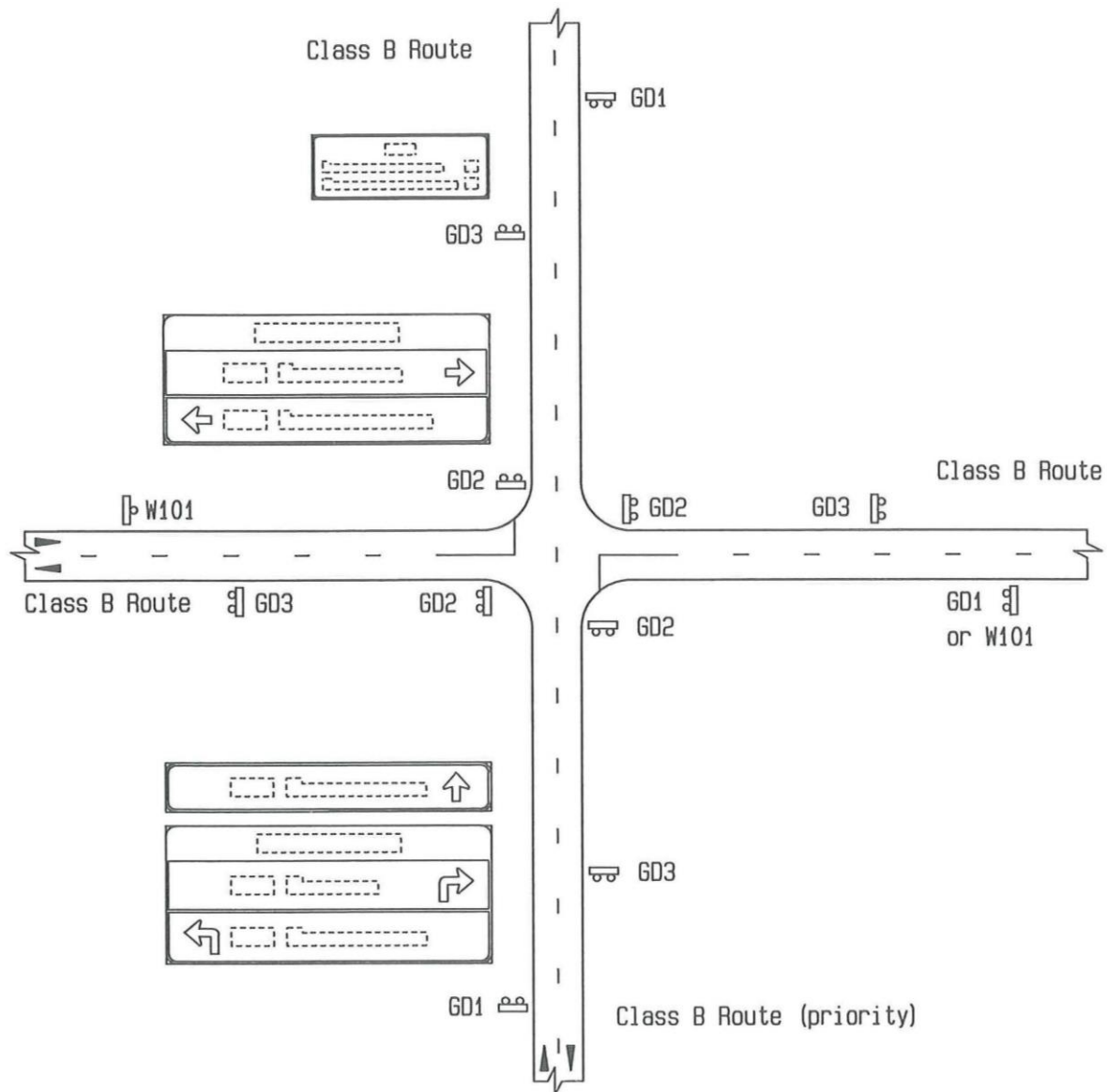

NOTES:

- (1) Figure 9.19 shows the preferred basic guidance sign sequence applicable at a junction between two urban Class B routes whether these are designated as N, R or M numbered routes.
- (2) LOCAL DIRECTION and/or TOURIST DIRECTION signs may be added to such sequence. For details of the use of these classes of sign in urban areas refer to Section 9.4 and 9.5.
- (3) According to a number of factors described in Section 9.6 this sequence may be varied to reduce sign-face area (and cost) and/or to fit signs into limited available space. For further details see Figures 9.49 to 9.52.
- (4) The function and application details of urban DIRECTION signs are described in full in Volume 1, Chapter 4, Section 4.8.
- (5) Figure 9.20 shows the minimum guidance signing level appropriate to this category of junction (B/B).

Fig 9.19

Basic Urban Guidance Signing Sequence – At-Grade Class B Junction – Preferred Signing Level

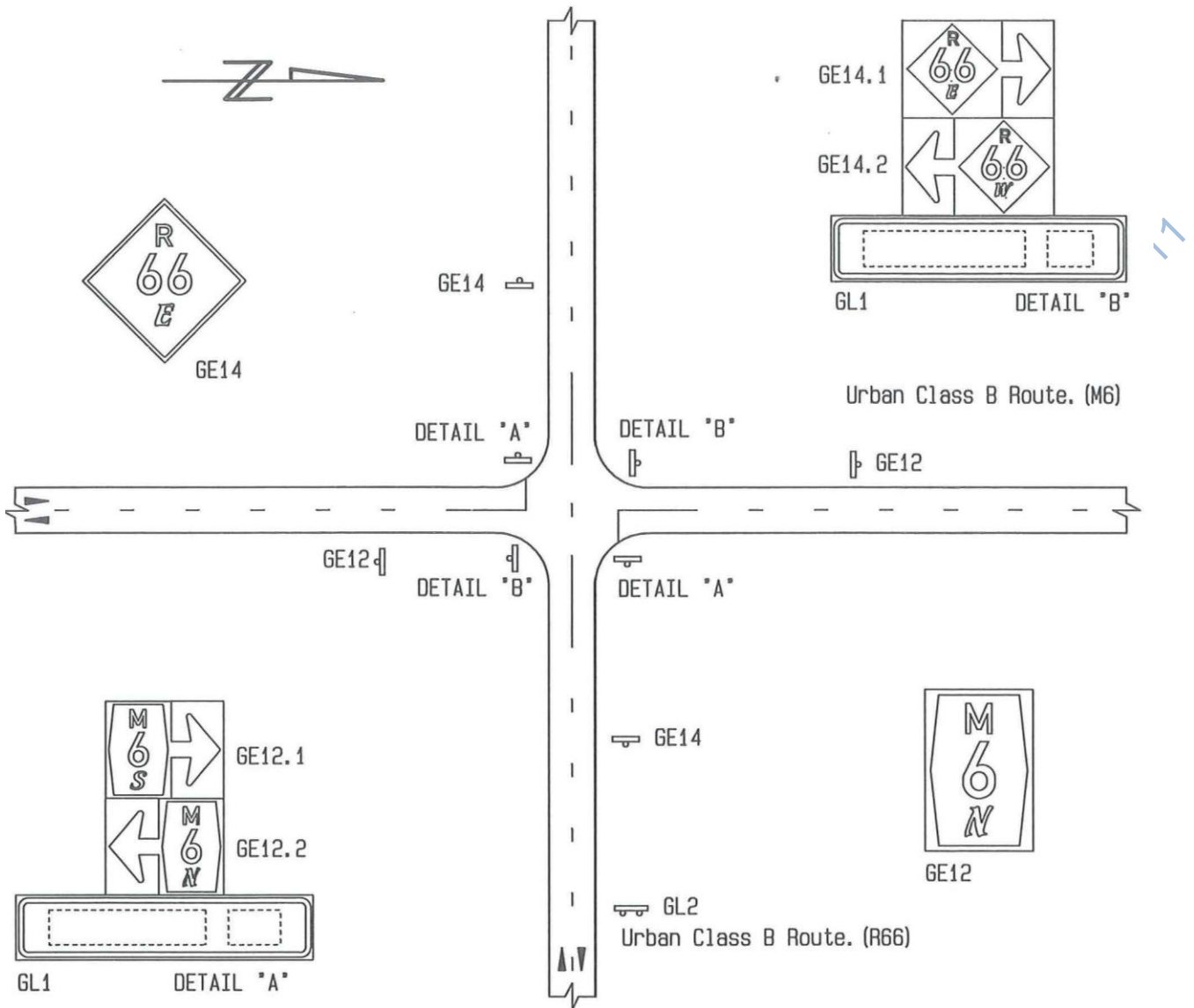

NOTES:

- (1) Figure 9.20 shows the minimum basic guidance signing level applicable at a junction between two urban Class B routes, whether these are designate as N, R or M numbered routes.
- (2) LOCAL DIRECTION and/or TOURIST DIRECTION signs may be added when appropriate. For details of these classes of sign in urban areas refer to Sections 9.4 and 9.5.
- (3) The function and application details of urban LOCATION (STREET NAME) signs and ROUTE-MARKER signs are described in full in Volume 1, Chapter 4, in Sections 4.6 and 4.7 respectively.
- (4) For dimensional details see Volume 4, Chapter 4.
- (5) Figure 9.19 shows the preferred guidance signing level appropriate to this category of junction (B/B).
- (6) Figures 9.49 to 9.52 in Section 9.6 illustrate a range of other options for signing Class B junctions.

Reprc

Fig 9.20 Basic Urban Guidance Signing – At-Grade Class B Junction – Minimum Signing Level

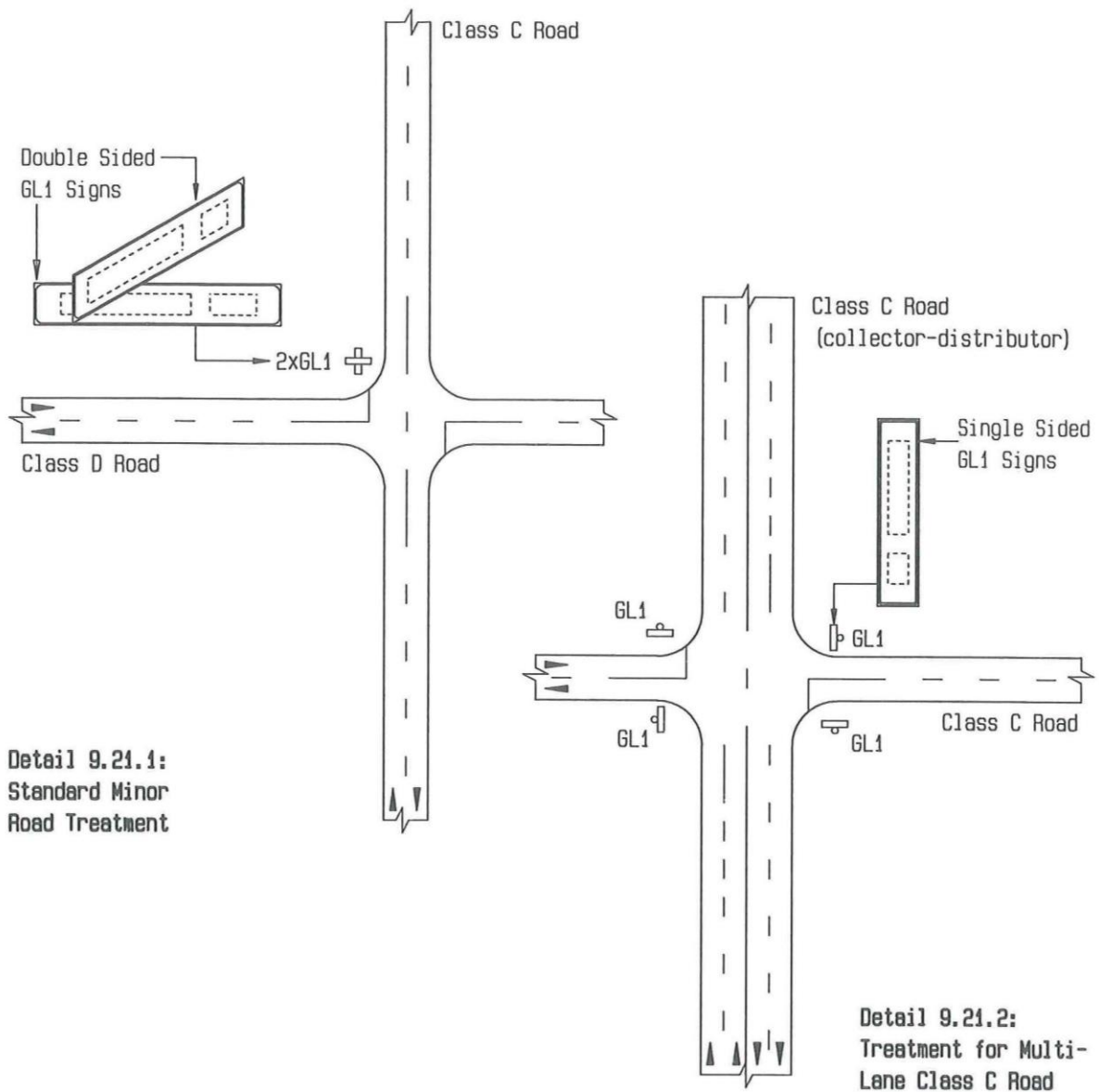

NOTES:

- (1) Detail 9.21.1 shows the absolute minimum guidance signing which must be provided at all urban junctions. This comprises two double sided STREET NAME signs GL1, commonly located on a single support. These signs should be located on one of the far side left corners for the priority road.
- (2) Detail 9.21.2 shows the preferred STREET NAME signing treatment when one of the intersecting streets has more than two lanes. This signing level requires four single-sided STREET NAME signs, all located on the far side left corners of the junction (for each approach).
- (3) Figures 9.53 and 9.54 in Section 9.6 illustrate a range of other options for signing minor urban junctions.

Fig 9.21

**Basic Minimum Urban Guidance Signing -
Class C and Class D Junctions**

Reproduced under Government Printers Authorization No. 11542 dated 7th July 2017

9.4 URBAN LOCAL DESTINATION SIGNING

9.4.1 General

- 1 Figure 9.8 in Section 9.3 describes the information given by guidance signs in diagrammatic form. The illustration develops the information given by the different classes of guidance sign into "Primary", "Secondary" and "Tertiary" layers. Tertiary information is non-orientational and as such can be supplementary to the "Secondary" (orientational) level signs, or it can be used at a lower level in the road network on its own. The "Tertiary" layer of information is provided by both LOCAL DIRECTION signs and TOURISM DIRECTION signs. There are many similarities between the two classes of direction sign. Figure 9.22 shows the relationship between LOCAL and TOURIST DESTINATIONS (for further information on urban TOURISM DIRECTION signs see Section 9.5).
- 2 The class of LOCAL DIRECTION sign has been provided to supplement the normal direction signing provided in terms of the Navigational Aids policy (see Volume 1, Chapter 8). LOCAL DIRECTION signs are therefore often supplementary to DIRECTION signs. The DIRECTION sign system, which is recommended on all Class "B" routes in urban areas, primarily provides navigational and orientational information. This information is given in the form of route numbers (Class "B" routes are numbered routes), and important destination names. The importance of a destination, in the context of its ability to provide orientation, is recognised by its designation as "familiar" "control" or "service". "Local destinations" are outside the framework of providing system navigation or orientation, but are considered to generate sufficient traffic interest to warrant the provision of LOCAL DIRECTION signs.
- 3 The provision of supplementary LOCAL DIRECTION signs on Urban Class "B" routes in addition to DIRECTION signs **must be carried out with care. It is not difficult, in a busy urban street environment, to overload drivers with information to the extent that they are unable to take all the information in.** The ultimate result of such a situation could be confusion leading to an accident, but at the very least the result is a waste of financial resources in providing the ineffective signs (see Subsection 9.4.7). **LOCAL DIRECTION signs shall not be used on freeways.**
- 4 **An optional application of LOCAL DIRECTION signs may be to use them exclusively on the more important un-numbered or tertiary arterial routes in urban areas instead of DIRECTION signs. If used in this manner they should provide an exit destination for each leg of the junction to which they apply.** Such a practice will ultimately reinforce the road network hierarchy to road users, due to the different signface colour codes (in a similar way in which freeway arterials are identified as higher in the road hierarchy by their blue background colour code). Examples of signs appropriate to this function are given in Volume 1, Chapter 4, Section 4.11 as individual sign types, and in Volume 4, Chapter 13.
- 5 Since the TOURISM DIRECTION and LOCAL DIRECTION sign sub-classes tend to deal with similar types of non-orientational destinations it can be difficult or confusing trying to allocate a particular type of destination to one or other sub-class. A detailed classification of tourist destination types has been developed and is given in Table 9.2. A more simple classification has been used for local destinations, which is recorded in Table 9.1 (see Subsection 9.4.3). In an urban environment it can be argued that it is probably more important to have uniformity of sign appearance rather than to be concerned about the strictly correct allocation of a destination to a class, particularly when considering low level-of-use destinations. The normal differentiation between classification as a tourist destination or not, ultimately relates to the purpose of travel being for pleasure or recreation.
- 6 In certain areas it is quite possible that the overall demand for local direction and/or tourism direction signs may be greater than can reasonably be catered for by the provision of individual signs for candidate destinations. Local authorities should approach such potential problem areas in a pro-active manner. A signing plan for local and/or tourism destinations should be prepared as part of the Urban Guidance Signing Plan (see Section 9.3) and Figure 9.16, Steps 10 and 13). Factors such as the following should be taken into account:
 - (a) an established road user need for a sign;
 - (b) the availability of access to the destination by the general public (rather than exclusive access to member groups);
 - (d) proximity of destinations to each other;
 - (e) traffic safety;
 - (f) competitive advertising;
 - (g) any other relevant factor.

Part of a pro-active plan for an area with a potential for an over demand for signs should be the centralisation of information at INFORMATION CENTRES, BUREAUX or LAYBYS (see Section 9.5). **A well organised approach to this level of guidance signing is to be preferred over the permitting of uncontrolled, informal signs to local or tourism destinations by the operators of the facilities at the destinations.**
- 7 LOCAL DIRECTION signs are very similar in principle to TOURISM DIRECTION signs (see Subsections 9.4.2, 9.4.4 and 9.4.5). Wide use is made of symbols to achieve message transfer to drivers. This is intended to reduce the need for text on signfaces to a minimum, wherever possible. The symbols used on LOCAL DIRECTION signs must be approved, and aesthetically acceptable.
- 8 LOCAL DIRECTION signs are either STACK-TYPE signs or FINGERBOARD type signs. ADVANCE LOCAL DIRECTION sign GDL1 and LOCAL DIRECTION sign GDL2 are STACK-type signs. They will most commonly be used as single stack signs but multiple stack-type signs may be used when appropriate. ADVANCE LOCAL DIRECTION signs GDL1 shall be located in advance of the turn to which they apply, and, unless this is the final turn towards the destination, they will not normally be followed by a LOCAL DIRECTION sign GDL2. Sign GDL2 is normally used at the final turn towards the destination, which may be the actual access point to a property. When used in addition to DIRECTION

- signs or ROUTE MARKER signs on a Class "B" route, sign GDL1 should be located approximately 2/3 of the distance from the turn that ADVANCE DIRECTION sign GD1 is located (see Figure 9.19). If ADVANCE LOCAL DIRECTION sign GDL1 and LOCAL DIRECTION sign GDL2 are both to be used, as a systematic provision of destination information on urban un-numbered but important traffic carrying routes, they should be positioned as indicated in Figure 9.19 for normal DIRECTION signs. Figures 9.23 to 9.26 illustrate various applications of LOCAL DIRECTION signs.
- 9 FINGERBOARD signs GDL3 may be used in a similar manner to either sign GDL1 or sign GDL2, but at a lower level in the urban street network, or to lower level of use destinations (see Subsection 9.4.3). If a local authority chooses to use sign GDL3 in significant numbers it is recommended that an assessment of likely destination types be made and a standard length of sign be used. This can result in an attractive and ordered appearance, particularly if many signs are to be provided.
 - 10 If multi-stack LOCAL DIRECTION signs are required a local authority may opt to use COMPOSITE LOCAL DIRECTION signs GDL1/GDL2 (see Detail 9.26.2). This sign type permits the combination of elements of the ADVANCE LOCAL DIRECTION sign GDL1 and the LOCAL DIRECTION sign GDL2.
 - 11 When a local authority uses LOCAL DIRECTION signs in place of DIRECTION signs, as described in paragraph 9.4.1, a street name may be combined with sign GDL2 as illustrated in Figure 9.26 (see Volume 1, Chapter 4, Subsection 4.11.10 and Volume 4, Chapter 13).
 - 12 LOCAL DIRECTION signs may incorporate tourism information in an insert panel and local direction information may be incorporated into DIRECTION signs as an insert panel, or as a complete stack (see Volume 1, Chapter 4, Subsection 4.11.10 and Volume 4, Chapter 13).
- ### 9.4.2 Local Direction Signing Principles
- 1 LOCAL DIRECTION signs, as a sub-class of the guidance sign class, perform a function similar to DIRECTION signs but tend to embody many of the principles developed for TOURISM DIRECTION signs.
 - 2 LOCAL DIRECTION signs provide tertiary level information (see Figure 9.22). As a group they should not be seen as providing a medium to carry an overload of information from the DIRECTION sign system. In a similar sense the information they do provide must be considered in the context of the level of information also provided by DIRECTION and TOURISM DIRECTION signs at specific sites. **It is not good practice to exceed the design criteria for the transfer of information (see Volume 1, Chapter 4, Section 4.4).**
 - 3 For orientational DIRECTION signs to function effectively, it is recommended that a stack should be provided for each exit path from a junction i.e. for a crossroad junction this means a stack for the straight-on direction and one each for the right and left turn directions. **Since local direction signs do not have an orientational function stacks should only be provided for those directions serving warranted local destinations** (however, see paragraph 9.4.1.4). This principle is the same as that used for tourist direction signs.
 - 4 On the approaches to a Class "B" junction, ADVANCE TURN tourism signs GF2 and ADVANCE LOCAL DIRECTION signs GDL1 may be located at two-thirds and one-third of the distance from the junction which would be appropriate for an ADVANCE DIRECTION sign GD1, respectively. Alternatively the two types of sign may be mounted on common supports, one above the other, or they may be designed as a single composite sign, either of which types of sign should be located at "two-thirds GD1" distance from the junction (see Figures 9.23 to 9.26).
 - 5 LOCAL DIRECTION signs GDL2 or FINGERBOARD signs GDL3 should normally only be located at the final turn towards, or at or opposite the point of access, to the local destination (see Figures 9.24 and 9.25).
 - 6 If an urban authority wishes to provide local direction signs for the lower categories of local destination (see Table 9.1), mainly on Class "C" and "D" streets, then a system using only LOCAL FINGERBOARD signs GDL3 may be adopted.
 - 7 It is likely that there will be a demand for both local direction and tourist direction signs at many junctions. **This will add to driver workload when all signs are required, and this aspect must be taken into account in the design (see Volume 1, Chapters 1 and 4).** Therefore, if local AND tourism direction signs are warranted at a junction, signs should preferably be provided in one of the ways indicated in paragraphs 9.4.2.4 and 9.4.2.5, namely:
 - (a) by combining the two signs on common supports so that the total sign message of the tourist and local destination signs is within the limits stated for a single sign; OR
 - (b) by designing a composite sign with the tourism message displayed as an "insert" panel on the ADVANCE LOCAL DIRECTION sign GDL1; PROVIDED that if the GD1 sign is not already in place, the position allocated for it from the junction should be increased by 50% if at all possible, and the distances of the supplementary sign be increased accordingly (see Figure 9.23).
 - 8 If local destinations require to be signed in more than one direction the resultant sign should conform to normal stack-type sign rules SUBJECT to any other provisions given below. This rule applies whether the sign concerned is a local sign, a tourism direction sign or a sign combining both destination types.
 - 9 If a numbered route carrying high volumes of traffic generated by local destinations intersects another numbered route which leads to several local destinations an attempt must be made to find group descriptions for the destinations to reduce the display demand. This may take the form of symbols plus SINGLE identifying names. (NOTE: the most likely solution to this problem should be the display of the appropriate collective name as a destination on the normal direction sign system, since, by virtue of its importance or familiarity it is likely to have orientational value - such a name may commonly be the name of the suburb in which all the local destinations are located.)

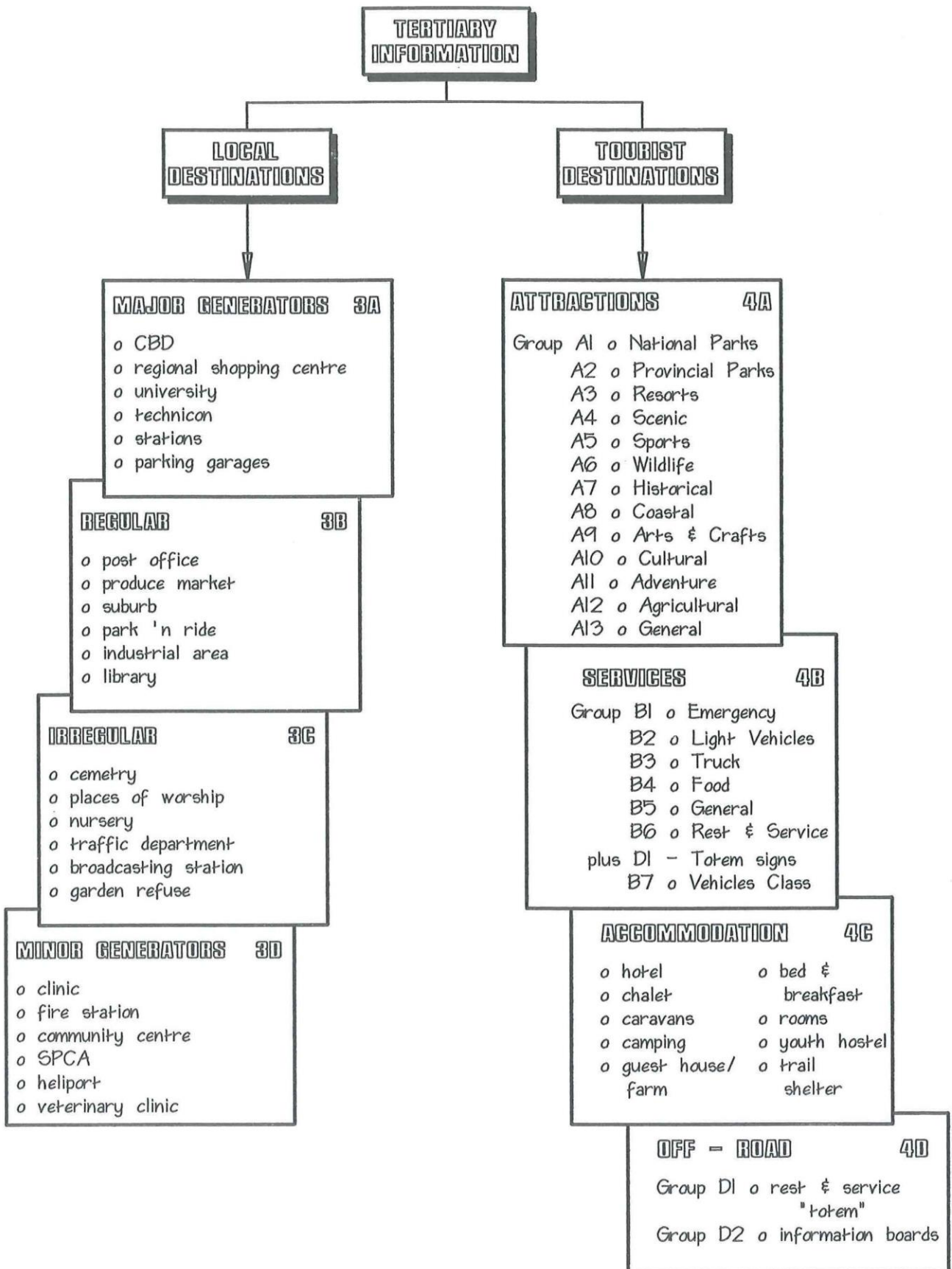

Re.

Fig 9.22

Tertiary Level Guidance Information

- 10 Once a local destination has been signed the principle of message continuity shall be applied so that it is signed through subsequent changes of direction until the destination is reached (NOTE: for this reason straight-on local direction stacks are not normally recommended.)
- 11 A LOCAL DIRECTION sign, as with any other road sign, shall be legible. However, the principle used in the tourism signing system of using one letter size smaller than used on the normal DIRECTION signs should be considered for LOCAL DIRECTION signs if the amount of information displayed is limited. For urban applications this rule should be subject to a normal minimum letter size of 175 mm /125 mm. A letter size less than 140 mm / 100 mm shall not be used.
- 12 **A limit of 8 "bits" of information should be applied to any combined local/tourism direction sign. If separate signs are used each should be limited to 6 "bits" of information (NOTE: This provision will, particularly in combination with normal direction signs, potentially allow very high levels of information to be displayed. Such high levels of information should not be permitted if all other relevant design factors are not of the highest order i.e. if sub-standard letter sizes are being used - see Volume 1, Chapter 4).**
- 13 **Subject to the limitation on the number of "bits" of information given above, the maximum number of destination names which may be displayed on any local direction sign or combined local/tourist direction sign shall be four names.**
- 14 Correctly colour coded route trailblazer panels may be incorporated in the form of "insert" panels, subject to other rule requirements. Such route trailblazer information could be appropriate for drivers wishing to move upwards in the street hierarchy from the local level. It should be noted that if a TRAILBLAZER sign in the GE series is required at a junction it is normally located in the same position as that recommended above for LOCAL DIRECTION signs.
- 15 If more than one destination name is to be provided on a local direction sign stack, it is recommended that, where possible, the order of appearance of the destination names should such that the name requiring a driver response first be placed above any name in the stack requiring a later response i.e. if one destination is reached before another it should be above the other, OR if a turn comes up first which leads to one destination, that destination should appear above the other.
- 16 **The LOCAL DIRECTION signing system should not be seen as an overflow system for the primary and secondary systems.**

9.4.3 Classification of Local Destinations

- 1 The scope for a destination to qualify for inclusion on a LOCAL DIRECTION sign is vast. Subsections 9.4.7 and 9.4.8 deal with warrants for local destinations.
- 2 Local destination types, which have been identified to date, have been classified into four groups based largely on the level of traffic which the destination generates, or may be likely to generate in the future. A selection of these destination types

is illustrated in "layers" 3A to 3D in Figure 9.22. A more complete list is given in Table 9.1 but it is likely that local authorities will need to consider additional types of destination for classification from time-to-time. **The level of traffic generation used to classify local destinations is not precise.** This is because in one local authority area a specific destination type may generate far more traffic than the same type of destination in another local authority area. The boundaries between the different classes need not therefore be considered to be rigid. The classes of local destination are described as follows:

- major traffic generator - major use - traffic has significant daily peaks and continues all day long;
 - major traffic generator - regular use - traffic does not peak significantly but there is all day use for five or six days of the week;
 - minor traffic generators - irregular use - traffic may be quite high on one or two days of the week but at a much lower level on other days;
 - minor traffic generators - minor use - low traffic levels but still reflecting a public demand.
- 3 It should be noted that although transport terminal destinations such as railway station, airport, bus station, harbour and heliport, and CBD's, industrial areas and power stations are listed as local destination types at a local level, they may also appear on primary (Class "A" routes) and secondary (Class "B" routes) DIRECTION signs, if they are large generators of traffic.

9.4.4 Signface Design Principles

- The general principles relating to guidance signface design and layout are covered in Volume 1, Chapters 1 and 4.
- The signface design principles for LOCAL DIRECTION signs are essentially the same as those developed for TOURISM DIRECTION signs. LOCAL DIRECTION signs are likely to be generally simpler in layout than TOURISM DIRECTION signs due to the lesser need to display multiple symbols (tourist services) and the relatively rare likelihood of more than one local destination in one direction. LOCAL DIRECTION signs **do not** have the cut-back vertical side used on TOURISM DIRECTION signs and are therefore rectangular. The use of these standards means that the internal spaces are 20% to 30% less than on DIRECTION signs which is considered acceptable in terms of the supplementary role of LOCAL DIRECTION signs.
- The use of DIN 1451 Style "B" lettering is recommended. Consideration may be given to the use of DIN 1451 Style "A" lettering in low speed urban environments.
- LOCAL DIRECTION signface design places a high reliance on bold SYMBOLS to transfer the main part of the message to road users. When the PRIMARY name of a destination is also used it is used to qualify the reference of the symbol.** The vertical signface dimensioning is related to these symbols rather than the text. The height of each symbol is capable of supporting two lines of text without increasing the vertical height of a sign or

TABLE 9.1

LOCAL DESTINATION CLASSIFICATION

TABLE 9.1

Grouping According to Traffic Generation			
Group 3A	Group 3B	Group 3C	Group 3D
MAJOR USE	MAJOR GENERATORS REGULAR USE	IRREGULAR USE	MINOR GENERATORS MINOR USE
Central Business Area ⁽¹⁾⁽²⁾ Regional Shopping Centre ⁽³⁾ Railway Station ⁽¹⁾ Airport ⁽¹⁾ Bus Station ⁽¹⁾ Harbour ⁽¹⁾ Mine Parking Garage Modal Transfer Station	Information Layby Post Office Automatic Teller Industrial Area Park 'n Ride Waste Disposal Site Produce Market Conference Facilities Educational Establishment Swimming Pool Civic Centre Licencing Offices	Cemetery Garden Refuse Places of Worship Sports Club Traffic Department Electricity Department Testing Grounds	Clinic Fire Station Community Centre Heliport Bicycle Route ⁽⁴⁾ SPCA/AACL

NOTES:

- (1) These destination Types may also be used within the primary and secondary direction signing systems.
- (2) Central Business Area can also be signed in smaller towns at a lower level of warrant.
- (3) Shopping centres (or business areas) may be signed in smaller towns at a lower level of warrant.
- (4) A bicycle route should be signed within the route using BICYCLE ROUTE MARKER signs GE17 – see Volume 1.

GENERAL NOTES:

- (1) The signing of all local destination types is subject to warrants (see Subsections 9.4.7 and 9.4.8)

sign stack. Two techniques are therefore recommended to further contain LOCAL DIRECTION sign sizes when text is involved. These techniques are:

- (a) if the PRIMARY name is a two or more part name-
e.g. "Durban Deep" (mine)
then the name could be placed in two lines in a right-justified form -
e.g.

Durban		Deep
--------	--	------
- (b) if the PRIMARY name is long and can be satisfactorily hyphenated without risk of loss of meaning or readability then the primary name should be hyphenated and placed in two lines in a right justified form -
e.g.

Mwananya-	or	Chaman-
mala		culo

When, for ease of the arrangement of words, the lower line of text becomes longer than the top line, then the text should be left justified. Two or more lines of text referring

to two or more destinations of a common type (i.e. two schools) should be left justified.

- 5 LOCAL DIRECTION signs also **do not** use the multiple-panel layout of TOURISM DIRECTION signs. If one stack of a multiple-stack sign needs to display two local destinations they should appear in one stack, with the closer one above the further away one. If the two destinations are of the same type only one symbol need be displayed. If the two destinations are of different types then both relevant symbols should be displayed.
- 6 Since LOCAL DIRECTION signs are commonly used in supplement to DIRECTION signs on which route numbers are displayed, **route numbers shall not be displayed on LOCAL DIRECTION signs even if they are provided on a numbered route.**
- 7 The fact that route numbers are not used on LOCAL DIRECTION signs, together with the normal use of a symbol preceding the text, means that vertical justification between adjacent stacks is not normally worth providing. However, an improved aesthetic effect will result when two symbols are

required in one stack, if the symbols are centred over one another, and the following primary names are also left justified.

- 8 If a destination is located same distance beyond the final turn towards it, a distance may be included on the GDL2 or GDL3 sign. This treatment is not likely to be common in urban areas but can occur fairly frequently in "peri-urban" areas. The distance, given to the nearest 100 m, should be located below the destination name and right justified on it. The distance numerals should be followed by the letters "m" or "km" as appropriate.
- 9 When the local destination is at the end of the road and it is the only public destination, such a destination may be included in the stack of a DIRECTION sign, provided for the junction in question, within a white "insert panel" (see Volume 1, Chapter 4, Subsection 4.11.10).
- 10 The various signface design principles described in this section are specifically dimensioned for LOCAL DIRECTION signs in Volume 4, Chapter 13.

9.4.5 Symbols

- 1 The PRIMARY name of the local destination shall be preceded by an appropriate symbol when one is available. Only one symbol shall be used with one PRIMARY name.
- 2 If, for whatever reason, the use of a primary name is not considered necessary, a symbol may be used on its own in a LOCAL DIRECTION sign. Such a display may also include a distance in accordance with paragraph 9.4.4.8. This type of symbol-only LOCAL DIRECTION sign may be used as a "follow-up" sign for one or two turns after the first turn towards the destination, provided the same symbol appeared with the destination name as a GDL1 sign at the first turn.
- 3 LOCAL DIRECTION symbols are sized according to the same dimensional criteria as TOURISM DIRECTION symbols with a nominal design height and width of 15"d" where "d" is the letter stroke width used on the sign (and the letter height is 7"d"). LOCAL DIRECTION symbols may include symbols used on tourism signs, and those used on direction signs provided they are correctly sized.
- 4 If a symbol should need to be used with three PRIMARY names of three destinations, of the same type in the same direction, then the symbol size should be increased by one standard increment in the value of "d" i.e. from 20 mm to 25 mm, or 30 mm to 40 mm.

9.4.6 Shape, Size and Colours

- 1 LOCAL DIRECTION signs shall be rectangular in shape, with the exception of the FINGERBOARD type sign which shall have one side shaped to a point. All signs shall be provided with a border of a colour which contrasts with the sign background colour. PERMANENT direction signs have a horizontal format. TEMPORARY local direction signs used within construction sites should, where possible, minimise the horizontal dimension to reduce side space requirements.
- 2 The size of LOCAL DIRECTION signs is dependent on the symbol and destination messages to be displayed and the choice of letter size to be used (see Volume 1, Chapter 4, Section 4.3).

- 3 PERMANENT local direction signs shall have a white background colour with black legend and arrows and **blue border**. TEMPORARY local direction signs shall have a yellow background with all other signface details in black.
- 4 Special colour variations are permitted. A brown "insert" panel may be provided to display a tourist destination or in blue to include a freeway trailblazer message.

9.4.7 Warrants - General

- 1 Since LOCAL DIRECTION signs are supplementary to primary and secondary level direction signs, **the most important warrant to be satisfied in any specific urban guidance signing situation, involving the possible provision of LOCAL DIRECTION signs, is the ability of drivers to take in the proposed additional information in terms of their driving environment and workload. Therefore, if DIRECTION signs, and/or existing LOCAL or TOURIST DIRECTION signs, contain information in excess of the limits given in Volume 1, Chapter 4, Section 4.4, additional LOCAL DIRECTION signs shall not be provided.**
- 2 **As with supplementary tourism signs it is a basic hypothesis that, with the aid of map, brochures, verbal directions etc. the existing hierarchy of numbered routes, orientational destinations given on DIRECTION signs, and an adequate system of street name signs, drivers should be able to reach a point in relatively close proximity to their intended urban local destination, before supplementary local direction signs may be considered necessary.**
- 3 From this hypothesis the provision of LOCAL DIRECTION signs in urban areas should, **irrespective of any individual warrants applicable to the type of local destination**, conform to the following principles:
 - (a) **LOCAL DIRECTION signs are not warranted when the location of the destination concerned is obvious to road users**, PROVIDED that even if the location of the destination is obvious, if the access to it is not obvious, an appropriate LOCAL DIRECTION sign may be used to identify the point of access;
 - (b) **the provision of LOCAL DIRECTION signs should not commence further from the destination than the nearest numbered route;**
 - (c) the facilities available at the local destination must be of a **standard which is acceptable** to a reasonable road user;
 - (d) when a number of local destinations can be reached in one direction, from a particular junction, an attempt must be made to determine some **single collective name** which will adequately guide road users in the correct direction e.g. a suburb name may be more appropriate than the names of four or five local destinations within, or close to, such a suburb;
 - (e) in extreme cases where many local destinations (and indeed tourist destinations as well) occur, consideration must be given to providing a suitable **information layby or bureau** with enough local detailed information to simplify the local navigation process; the need for such a facility is

likely to have arisen from requests for signs from the relevant community or communities; in such a case a special effort will have to be made regarding the funding of the layby or bureau and its facilities, which in all probability will require direct involvement of the community.

- 4 When considering the application of warrants for local destinations it is very likely that the apparent need for a LOCAL DIRECTION sign will result either from a public need noted by the relevant urban authority based on observed problems or complaints received, OR from applications received from owners or operators of the local facility, who seek to ensure that the public can find their facility. **A very important reason for urban authorities to approach the provision of tertiary level supplementary direction signs with care is the question of precedence. Once one type of destination has been signed, it becomes very difficult to deny further applications to sign similar facilities particularly if the warrant or motivation for the original sign is in any way suspect.** Whilst it is necessary to approach the provision of guidance signs based on an application from a party representing a specific destination, in the fairest and most unbiased way, since there are very definite limits to the accumulation of road-side information which drivers can be expected to take in, **setting a precedent should be done with the full knowledge of its future implications.** Wherever possible any application for local direction signs should be assessed in terms of the real or perceived need for road users to find the facility concerned **and should not be seen simply as a means to promote competitive or commercial interests. It is not a requirement of road traffic signs that they should perform such functions.**
- 5 Detailed warrants relating to the provision of LOCAL DIRECTION signs in urban areas are given in Subsection 9.4.8. In deriving the warrants, the general provisions described in paragraph 9.4.3.2 relating to traffic generation characteristics have been used as a starting point. The following factors have been considered the most significant in developing further warrant criteria:
 - (a) traffic generation or attraction;
 - (b) frequency of use i.e. regularly or irregularly;
 - (c) the number and quality of facilities or destinations with due regard to the function and likely users of the facility;
 - (d) the distance from which the local destination may be considered for signing.
- 6 In order to qualify for the provision of LOCAL DIRECTION signs from the nearest numbered route a local destination must be classified in either Group 3A or Group 3B.
- 7 Local destinations in Groups 3C or 3D should normally only be signed at a local level on Class "C" or Class "D" roads and normally within a local traffic area. An authority may use discretion to upgrade a specific local destination classified in Groups 3C or 3D if it generates traffic commensurate with the requirements of Group 3A or 3B so that it may be signed from the nearest numbered route.
- 8 Authorities may also exercise discretion, particularly in upgrading the distance from which a local destination may be

signed, including the possibility of signing from one numbered route to another. The following conditions should be considered relevant:

- (a) if it can be demonstrated that a significant percentage of those travelling to a local destination travel from outside the region within which the destination is located the following factors may warrant discretionary relaxation of the distance at which the first sign may be located:
 - (i) the number of users from outside the region are at least 25% to 33% of all users, AND
 - (ii) the region can be considered to have a "catchment" of 5 km radius for towns or metropolitan areas with populations of less than 100 000 and of 10 km radius for towns or metropolitan areas with populations of 100 000 or more;
- NOTE: the onus to satisfy the relevant road authority with regard to the above requirements should rest with an applicant;
- (b) if there are several possible approach routes to the facility and the urban authority wishes to:
 - (i) influence the route used by drivers for whatever reason, or
 - (ii) avoid wasteful travel due to the possibility of incorrect choice of route, then discretion may be exercised;
 - (c) if the facility is located on a route (numbered), or street, close to and parallel to another numbered route, then discretion may be used when locating signs;
 - (d) if the road for which a sign is being considered is a by-pass.
- 9 If an urban authority decides to use discretion with regard to the norms governing sign positioning, the reasons for this action should be recorded to assist in resolving similar cases in the future, and to maintain consistent and defensible policies.

9.4.8 Warrants for Specific Urban Local Destination Types

- 1 The classification of local destination types into four groups, as described in Subsection 9.4.3 and as listed in Table 9.1, has been carried out to assist in developing a structured approach to the provision of warrants for signing local destinations. The warrants given in the following paragraphs are subject to review once they have been in the use for sufficient time to access their effectiveness. The warrants developed for destination types in groups 3A and 3B are more rigorous, and more difficult to comply with, than those for group 3C and 3D type destinations.
- 2 The warrants given below are provided in an attempt to assist urban authorities approach local destination signing in urban areas in a consistent and structured manner. Some urban authorities may well feel that they have to adopt a more relaxed or stringent warrant than that stated, due to their specific circumstances. There is no reason why different authorities may not adopt different warrants, but it will help if they are related to those developed in this Chapter. It is important, therefore, that reasons for varying warrants are recorded for input to future reviews, and for the development training of new staff dealing with the provision of urban guidance signs. As has

been indicated in Figure 9.16, the provision of LOCAL DESTINATION signs can be planned on a pro-active basis as part of the Urban Guidance Signing Plan (see Steps 10 and 13 in Figure 9.16). Applications for LOCAL DESTINATION signs will also be received from road users and those operating from local destinations. In the event of a dispute over the provision (or not) of LOCAL DIRECTION signs, it is important that applicants be made aware of the environmental and road safety aspects of an over-supply of information. Any dispute should be processed on the basis of consultation with the role-player representatives identified during the development of the Urban Guidance Signing Plan.

3 Subject to all other provisions mentioned above the warrants for the provision of local direction signs for Group 3A facilities are as follows:

(a) regional shopping centre:

- (i) may be signed when the factor – "gross leasable shopping area (m²)/distance (km) from the nearest numbered route by the shortest practical route agreed to by all involved authorities" $\geq 40\ 000$ subject to a minimum glsa of 40 000; AND
- (ii) there are at least 1 000 surfaced and marked parking bays;

(b) university, technicon, educational college:

- (i) may be signed when the factor - "on-site daily student population/distance (km) from the nearest numbered route $\geq 5\ 000$ subject to a minimum factor of 5000;

NOTE: separate campuses of one educational institution shall be assessed separately.

(c) central business area (particularly for towns with a population of 100 000 or less):

- (i) may be signed from the nearest numbered route irrespective of distance;

(d) airport, railway station, bus station, harbour, or modal transfer facility:

- (i) the destination name may be included on primary and/or secondary direction signs as an orientational destination when the transport terminal is of national or provincial significance - follow-up signing should remain part of the secondary direction sign system or utilise ADVANCE TRANSPORT TRAILBLAZER signs GE9;
- (ii) the destination name may be signed on local direction signs from the nearest numbered route irrespective of distance when the transport terminal is of regional significance, PROVIDED the terminal caters for 3 000 or more passengers per day;
- (iii) the destination may be signed by a maximum of three local direction signs located up to 1km from the facility or on the nearest numbered route, whichever is the shorter distance, when the transport terminal is of local significance, PROVIDED the terminal caters for 500 or more passengers per day and/or large quantities of freight;

(e) mine within an urban area (operational):

- (i) may be signed from the nearest numbered route irrespective of distance PROVIDED the mine "community" comprises 20 000 or more people;

(f) parking garage or surface parking lot:

- (i) may be signed from the nearest numbered route irrespective of distance, PROVIDED parking is normally available for most of the day on a casual basis and the garage or parking lot has at least 100 bays - in a major urban area a comprehensive signing system may be required to indicate parking availability - local direction signs may be an integral part of such a system.

NOTE: distance parameters given in this paragraph apply between the point at which a sign is being considered and the point of access to the facility.

4 The local destinations listed in Group 3B may be signed from the nearest numbered route, provided this falls within the distance parameter indicated for each type of facility below. If a distance warrant permits signing from a specific distance, and a numbered route does lie within that distance, the warrant does not extend to signing from one numbered route to another up to the distance indicated in the warrant. Subject to all other provisions mentioned in this subsection the warrants for the provision of local direction signs for Group 3B facilities are as follows:

(a) conference facility, research organisation:

- (i) may be signed when the facility has auditorium or lecture space for at least 500 delegates, AND
- (ii) there are on-site parking spaces for all delegates;

NOTE: if conference facilities are part of the facilities offered by some other type of identified local destination such as a research organisation then only one local direction sign may be provided at the warranted distance - local direction signs may, however, subsequently be used for individual facilities, within a campus area, even if this includes public streets.

(b) suburb:

- (i) may be signed at the most significant access points (normally indicated by classified collector-distributor streets) when the suburb has 100 or more erven;

(c) industrial area:

- (i) may be signed at the most significant access points and from a distance of up to 2 km from such access point when the area is known to cater for traffic from outside the region;

(d) produce market, abattoir, power station:

- (i) may be signed, when the facility is of regional or greater significance, from a distance of up to 2 km;

(e) waste disposal site:

- (i) may be signed, when the facility is of regional or greater significance, from a distance of up to 5 km, OR

- (ii) if the facility caters for members of the public from a distance of up to 10 km or the nearest numbered route whichever is the closest;
- (f) park 'n ride:
- (i) may be signed from a distance of up to 1 km, PROVIDED there are more than 20 parking bays and that there are bays available on a regular basis;
- (g) school:
- (i) may be signed from the nearest collector-distributor street by a maximum of three local direction signs, PROVIDED that if the school has over 500 pupils, and hosts visitors from outside the immediate community, on a regular basis, such signs may commence from the nearest numbered route;
- (h) library:
- (i) may be signed from the nearest numbered route by a maximum of three local direction signs, subject to a maximum distance of 1 km - if a numbered route does not fall within such a range the facility should be signed, if required, from the nearest collector-distributor street;
- (i) post office:
- (i) may be signed by a maximum of three local direction signs subject to a maximum distance of 1 km, PROVIDED the post office offers a 24-hour telephone service;
- (j) layby (industrial or general information ie. not tourist):
- (i) may be signed from the nearest numbered route subject to a maximum distance of 1 km;
- (k) automatic teller:
- (i) may be signed in a central business area subject to a maximum distance of 500 m to 1 km, PROVIDED it is the only facility of its type in the area and a 24-hour service is available.
- 5 The main difference between Group 3C destination types and Group 3B destination types is the manner in which they are used. Any facility which is deemed to have a level of use which is more in line with the regular use prescribed for Group 3B destinations, may be considered for signing in terms of the most appropriate destination type in Group 3B i.e. places of worship may well have a level of activity similar to a medium sized school (approximately 500 pupils). Otherwise all the destination types in Group 3C may be signed by a maximum of three local direction signs so that the furthest sign is no more than 1 km from the facility, or is on the nearest collector-distributor street, whichever is the nearer, PROVIDED the facility has adequate on-site or adjacent parking for the local congregation who attend an "event" at the facility.
- NOTE: an "event" may include a funeral, a church service, a sports meeting, a concert or similar activity.
- 6 Group 3D destinations may be signed by a maximum of two local direction signs so that the furthest sign is no more than 500 m from the facility, or is on the nearest collector-distributor street, whichever is the nearer, PROVIDED the facility has adequate on-site or adjacent parking, where appropriate, and that visitors do not cause any annoyance or hardship to neighbouring residents.
- 7 Several of the local destination types listed may cover a large area and may, in themselves, include "sub"-facilities which may warrant signing. Such facilities should only be signed within the immediate environs of the original destination. Such signs may even include a mixture of local destination signs and tourist destination signs. For example, a working harbour may well have internal destinations which can be considered for local direction signing, and others which warrant tourist signs.
- 8 One-off events, or very irregular events, which do not warrant the provision of permanent local direction signs, may be signed using temporary LOCAL FINGERBOARD sign TGDL3. An urban authority may erect these temporary signs for the duration of the event, or they may authorise a suitable service organisation, such as the Automobile Association, to act on their behalf. The warrant for the provision of sign TGDL3 should be similar to that applicable to the most comparable type of local destination, without the application of any long-term criteria.

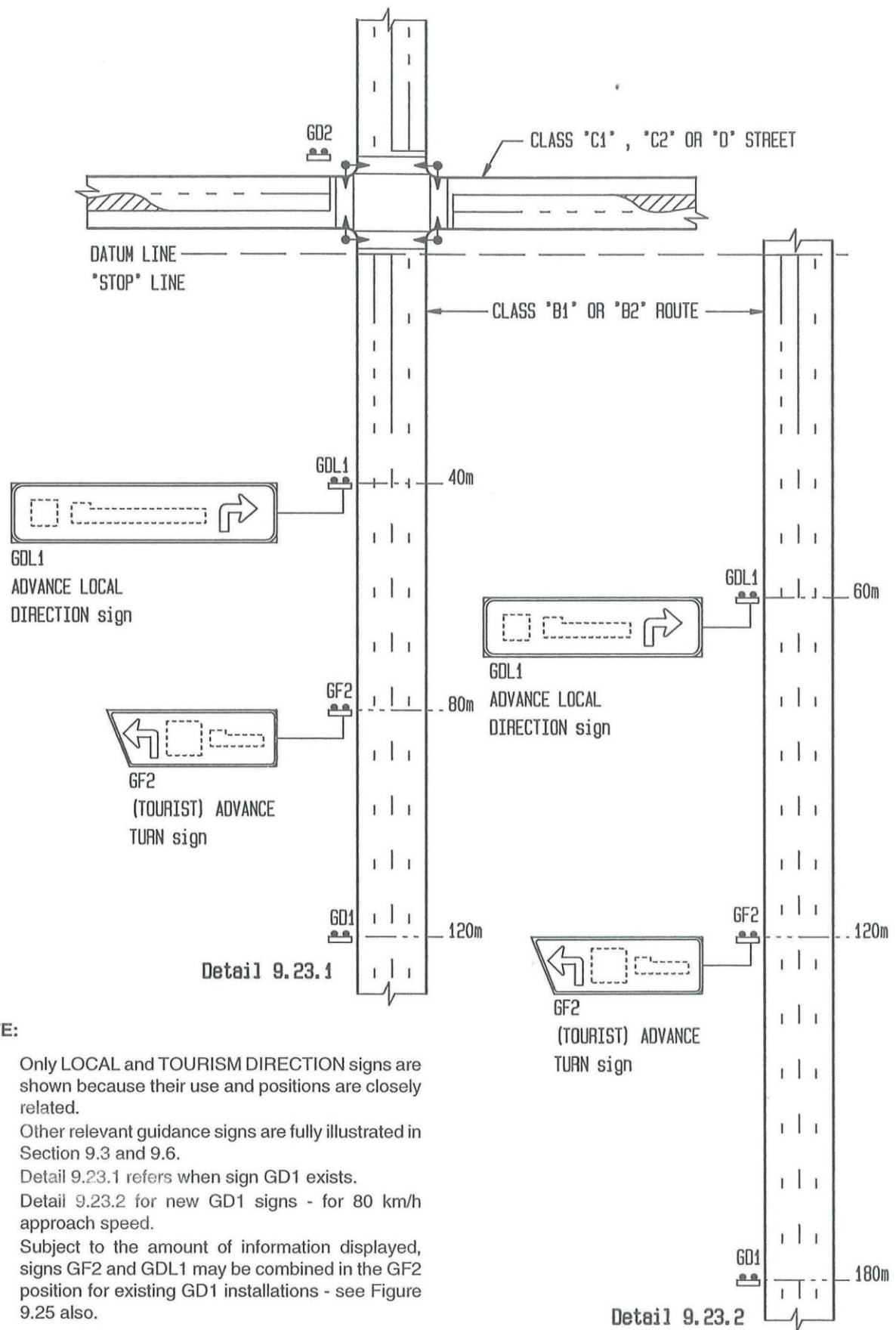

NOTE:

- (1) Only LOCAL and TOURISM DIRECTION signs are shown because their use and positions are closely related.
- (2) Other relevant guidance signs are fully illustrated in Section 9.3 and 9.6.
- (3) Detail 9.23.1 refers when sign GD1 exists.
- (4) Detail 9.23.2 for new GD1 signs - for 80 km/h approach speed.
- (5) Subject to the amount of information displayed, signs GF2 and GD1 may be combined in the GF2 position for existing GD1 installations - see Figure 9.25 also.

Fig 9.23 Supplementary Local Direction Signing – Class "B" Route

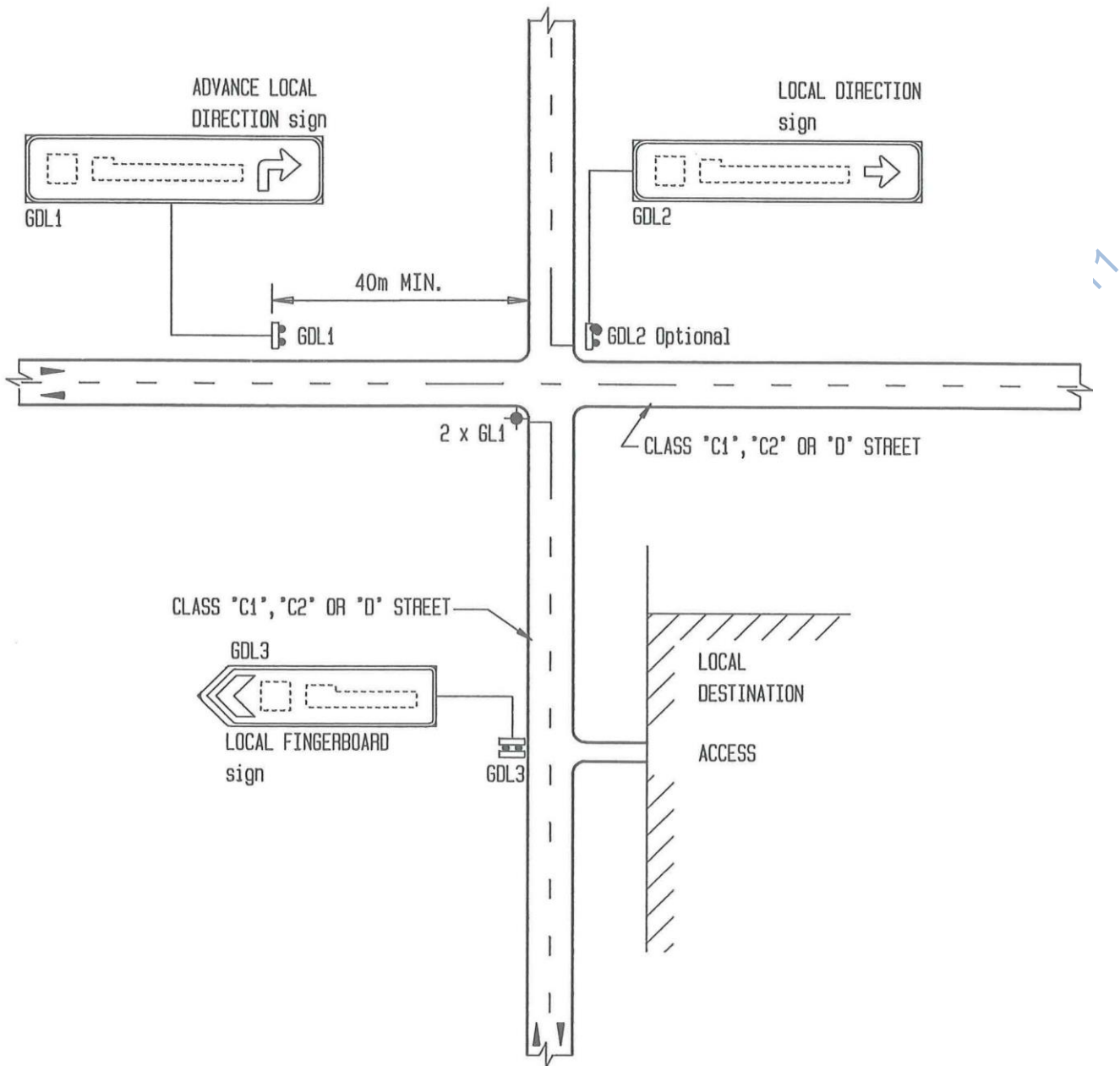

NOTE:

- (1) The LOCAL DIRECTION signs shown can be follow-up signs to the signs in Figure 9.23 or they may be the only signs used from a lower class of street (where DIRECTION signs are not warranted).
- (2) Arrangement may also be used from Class "B" routes using ROUTE MARKER signs.
- (3) The two GDL3 signs shown at the access allow for both directions of approach - this is optional.

Fig 9.24

Local Direction Signing – NO Standard Direction Signs

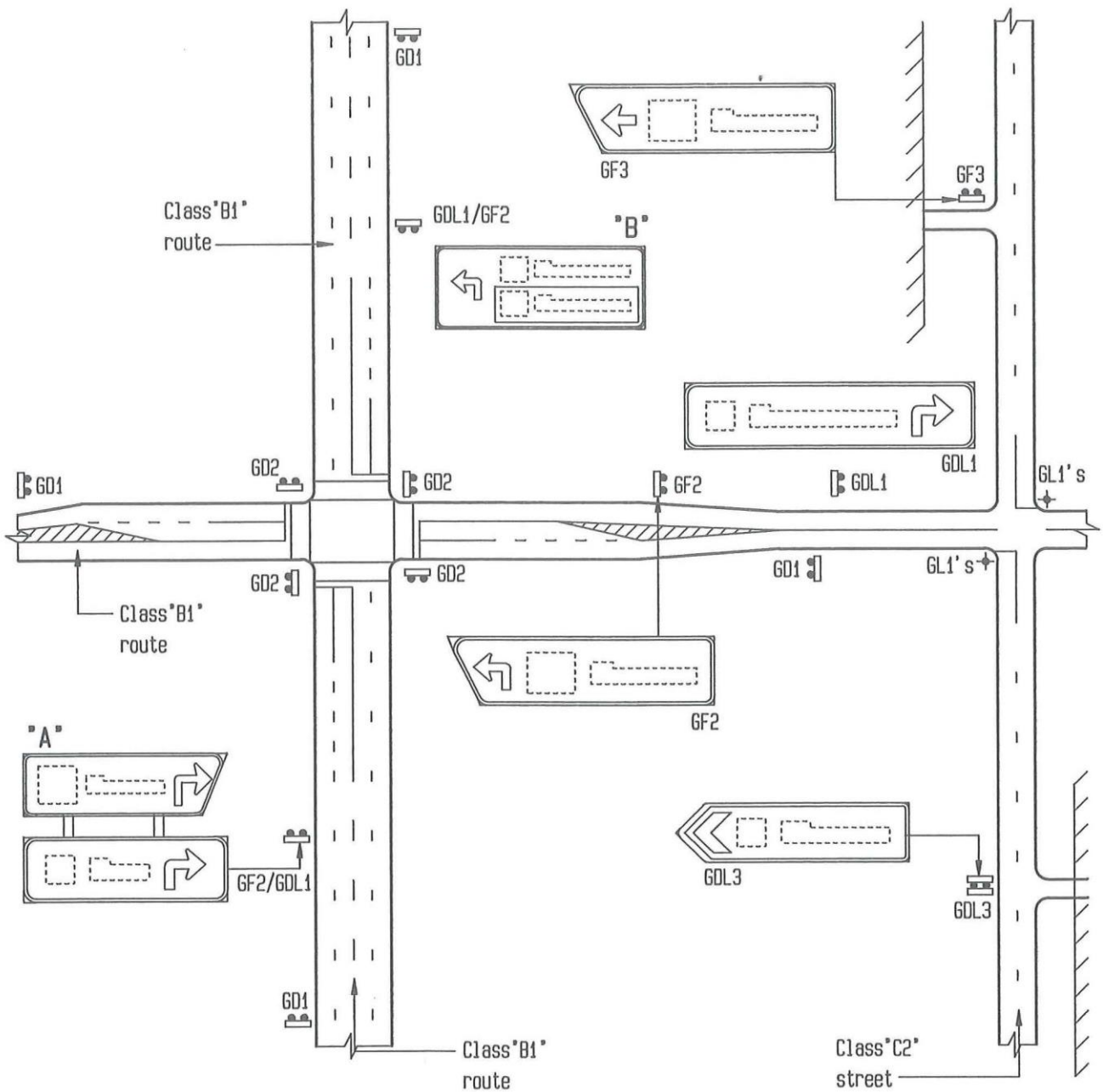

NOTE:

- (1) Only LOCAL DIRECTION signs are shown because their use and positions are closely related.
- (2) Other relevant guidance signs are fully illustrated in Sections 9.3 and 9.6.
- (3) Subject to the amount of information displayed, signs GF2 and GDL1 may be combined in the GF2 position for existing GD1 installations. The signs may be combined on a single signface at "B".

R6,

Fig 9.25

Local/Tourist Direction Sign Combinations

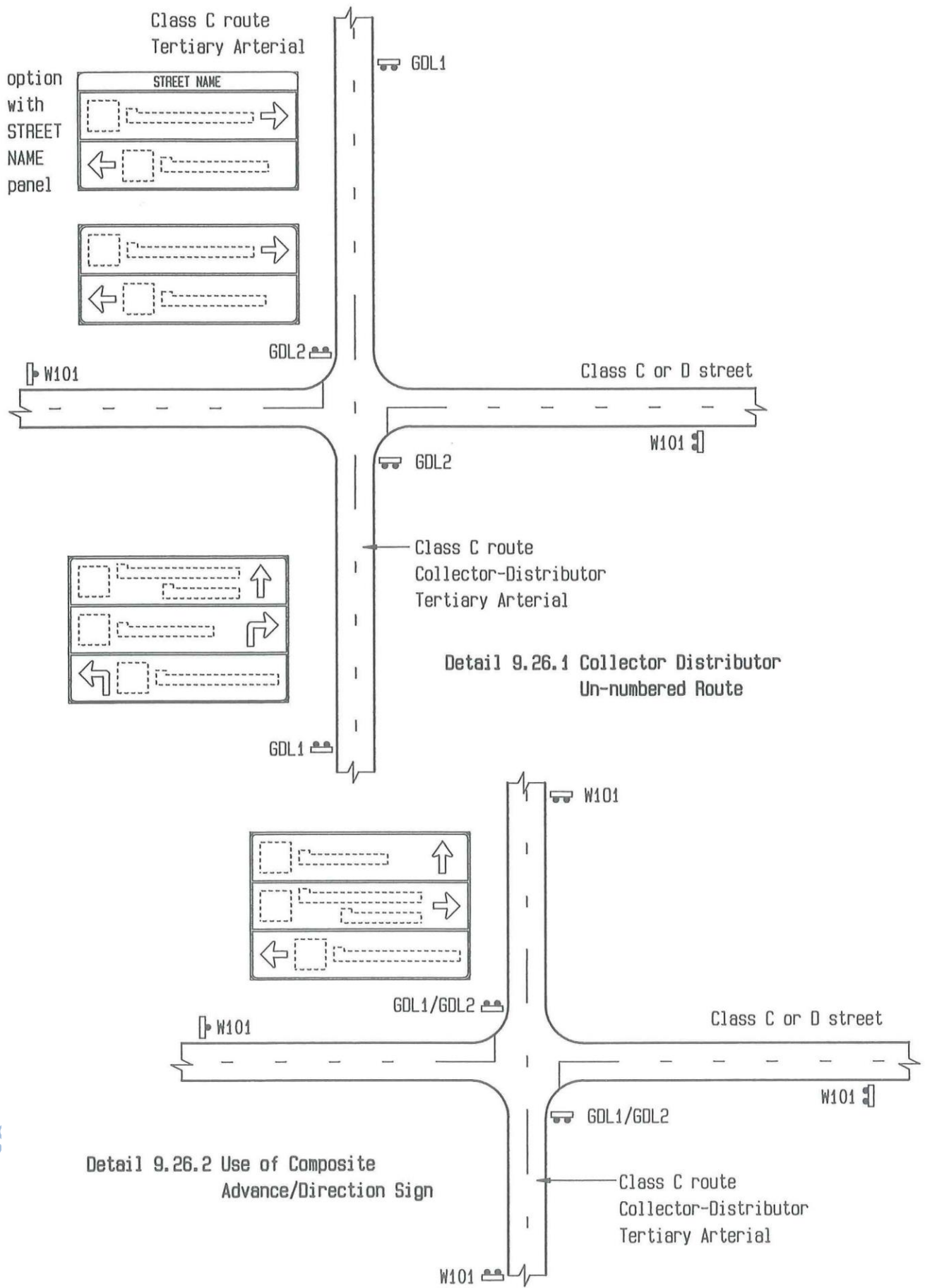

Rev

Fig 9.26

Local Direction Signing – Tertiary Arterial

Reproduced under Government Printers Authorization No. 11542 dated 7th July 2017

9.5 URBAN TOURIST DESTINATION SIGNING

9.5.1 General

- 1 This section is provided to complement the material given in Section 9.4 on the similar supplementary local destination signing with which tourist destination signs in urban areas will commonly have to be co-ordinated. In an urban environment the functional differences between the types of destination classified as *A*tourist^o and *A*local^o may be quite difficult to determine. In general terms an urban road authority can follow the classifications given in this chapter and is not likely to encounter much opposition from facility operators (regarding classification!). However, if an urban road authority wishes to exercise discretionary powers there is no strong reason why this cannot be done. For example, warrants are given in Subsections 9.5.10 and 9.5.11 which cannot be considered as obligatory. If an urban authority considers that there is good reason for applying a different, but similarly derived warrant, there is no reason why it should not do so. It is recommended that in such instances the authority record the warrant used, and the reasons why it is different. It is also recommended that authorities consult with adjacent authorities in this regard so that similar standards are ultimately applied in similar or adjacent areas.
- 2 It is a particular feature of tourism signing that the demand for signs is driven by tourist *A*destination^o owners or operators. This makes the role of the urban road authorities particularly onerous, because demand is always likely to exceed the ability to satisfy it, whether due to adherence to warrants, information display constraints, spatial constraints, or cost constraints. **A fundamental principle relating to the provision of tourism signs is that their function is to assist motorists reach their destination, and they should not be seen as advertising signs** (see Section 9.7).
- 3 In a general sense the approach taken in this chapter in differentiating between local and tourist destination types involves the following principles:
 - (a) local destinations tend to attract or generate traffic from within the urban community, although there will always be *A*tourists^o who seek these destinations as well;
 - (b) local destinations tend to occur as individual entities;
 - (c) tourist destinations, by virtue of their tourist attraction or service, tend to have a grouped attraction within a particular environment - to the extent that the concept of high density tourist areas has developed;
 - (d) tourist destinations tend to attract strangers or visitors from outside the urban community in which they occur.
- 4 Figure 9.8 in Section 9.3 describes the information given by guidance signs in a diagrammatic form. The illustration develops the information given by the different classes of guidance sign into *A*Primary^o, *A*Secondary^o and *A*Tertiary^o layers. Tertiary information is non-orientational and as such can be supplementary to the *A*Secondary^o (orientational) level signs, or it can be used at a lower level in the road network without other types of guidance sign. Figure 9.22 in Section 9.4 shows the relationship between TOURIST and LOCAL DESTINATIONS (for further information on LOCAL DIRECTION signs see Section 9.4).
- 5 The provision of supplementary TOURIST DIRECTION signs on urban Class *AB*^o routes in addition to DIRECTION signs must be carried out with care. It is not difficult, in a busy urban street environment, to overload drivers with information to the extent that they are unable to take all the information in. The ultimate result of such a situation could be confusion leading to an accident, but at the very least the result is a waste of financial resources in providing ineffective signs.
- 6 In certain areas it is quite possible that the overall demand for TOURIST DIRECTION and/or LOCAL DIRECTION signs may be greater than can reasonably be catered for by the provision of individual signs for candidate destinations. Local authorities should approach such potential problem areas in a pro-active manner. A signing plan for tourist and local destinations should be prepared as part of the Urban Guidance Signing Plan (see Section 9.3 and Figure 9.16, Steps 10 and 13). Factors such as the following should be taken into account:
 - (a) an established road-user need for a sign;
 - (b) the availability of access to the destination by the general public (rather than exclusive access to member groups);
 - (c) proximity of destinations to each other;
 - (d) traffic safety;
 - (e) competitive advertising;
 - (f) any other relevant factor.

Part of a pro-active plan for an area, with a potential for an over demand for signs, should be the centralisation of information at INFORMATION CENTRES, BUREAUX or LAYBYES. A well organised approach to this level of guidance signing is to be preferred over the permitting of uncontrolled, informal signs to tourism or local destinations by the operators of the facilities at the destinations.
- 7 Chapter 4: *Tourism Signing* deals in depth with all aspects of tourism signing including all facets of tourism signface design and tourism symbols. Chapter 4 has developed largely from the need to provide tourism signing in rural environments. However, the majority of the coverage of Chapter 4 is also relevant to urban, metropolitan and particularly peri-urban environments. Material given in Chapter 4 will not generally be repeated in this chapter. **Readers are therefore recommended to familiarise themselves with Chapter 4 if tourism signing is of specific interest to them.**
- 8 Chapter 4 also introduces the concept of *A*high density tourism areas^o. Such areas are particularly likely to develop in peri-urban environments. The signing of high density tourism areas is therefore covered in some detail from the urban perspective in Subsection 9.5.8.
- 9 A specific aspect of tourism signing which has proven to be a problem in the past, and which results from inadequate co-operation between road authorities with abutting areas of responsibility, is that of *A*follow-up^o signing. The problem has traditionally resulted from one road authority providing signs on its road network, for a facility within another road authority's

network. This tends to put an obligation on the latter authority to provide 'follow-up' signs leading to the facility, or negotiate with the facility representatives to do so, when the provision of the signs may be contrary to the specific signing policies of the latter authority. This problem may commonly arise in a by-pass situation. It is considered bad signing practice not to follow-up on the first sign towards a facility, through subsequent changes in direction, until the final turn towards the facility.

9.5.2 Structure of Tourist Organisations

- 1 Chapter 4: *Tourism Signing* recommends that tourism signing be approached in a structured way with high levels of co-operation and co-ordination between the various road and tourism authorities and organisations. Figures 4.1 and 4.2 in Chapter 4 illustrate a possible approach to such structures from Provincial to local levels. Figure 9.27 expands upon the urban elements of the Chapter 4 figures. Chapter 4 also provides an organisational flow-chart for the processing of requests from tourist facility owners or operators for tourism signs (Figure 4.4). Whilst the range of authorities catered for in this flow-chart is much greater than will be involved in an urban area, the principles covered by the chart are recommended for use in urban areas.
- 2 In order to achieve an adequate structure to handle tourism information, including that provided by tourism signs, the various levels of tourism organisation must manage, market and co-ordinate this information **for the benefit of tourists**. In doing so, they will inherently promote the welfare and development of tourism in the area. In an urban context this management of information will take a number of forms, largely dictated by the size of the urban area and its proximity to other urban areas. Figure 9.27 illustrates a typical structure appropriate to large cities and metropolitan areas, and to small to medium sized towns. Ultimately, whatever the size of the specific urban area, its Local Tourism Organisations (LTO's) will have a place in the line of communication to a Regional Tourism Organisation (RTO) and the Regional Tourism Liaison Committee (RTLCL). Urban tourism organisations, commonly publicity associations, should rely on their association with the RTO and RTLCL for assistance and guidance on facility standards, consistent application of warrants etc. The functions of these organisations differ within the different organisational levels, but as far as tourism signing is concerned, common functions of each organisation include:
 - (a) liaison with all role players to identify the need for tourism signing in the relevant area of jurisdiction;
 - (b) development of an understanding of guidance signing principles and the incorporation of these into criteria developed for the signing of facilities;
 - (c) the preparation of a tourism signing plan for the area under their jurisdiction;
 - (d) active participation, at appropriate levels, in tourism communities comprising tourism, roads and other officials, to consider and process applications for tourism signs.
- 3 Membership of the various tourism organisations is split between public and private sectors, although the tendency is for this type of activity to become a privatised activity under the

jurisdiction of agencies. Traditionally, representation on the national and provincial NTO and PTO's, comes from the public sector. The activity of the NTO and PTO's are primarily directed at protecting the public, and thereby tourists interests, by specifying quality standards for facilities and seeing that these are adhered to.

- 4 RTO's and LTO's are most commonly operated by the private sector. Their activities therefore tend to be directed for the benefit of tourist facility operators, which is not to say that the interests of tourists are ignored. In some instances an RTO may be a public run organisation but such instances are likely to decrease with time. In an urban environment RTO's, and LTO's in particular, are likely to be provided, supported and sponsored by the town's or city's Chamber of Commerce. As such, LTO's will commonly function broadly as publicity associations. The terms of reference of a publicity association are much wider than the promotion of tourism, since the associations deal with all facets of business promotion in the town or local council area. It is also likely that the skills of the personnel involved in LTO's may be limited with specific regard to tourism signing. It is therefore recommended that the public sector NTO and PTO representatives make a specific effort to develop awareness of the relevant criteria through the activities of the Regional Tourism Liaison Committee's and through workshops and seminars if necessary. The Regional Tourism Liaison Committee, by virtue of its representation (see Figure 9.27), includes members from both the public and private sectors of the tourism industry. As such it can offer an ideal forum to resolve differences and foster high quality tourism signing practices.

9.5.3 Urban Tourism Direction Signing Principles

- 1 **The signing of tourist destinations in urban or metropolitan areas should be strictly controlled simply because of the size of the demand and the practical difficulties in satisfying it, and because of the potentially degrading effect on the urban environment of a proliferation of signs, road traffic signs or otherwise.** These difficulties are much more prevalent in metropolitan areas than in smaller urban centres. Tourists do still, however, need to access all levels of tourist attraction, emergency service, and accommodation facilities in almost all urban areas, large or small. **More so than ever, the principle that a facility which is clearly visible does not warrant the provision of a sign, should apply to tourist facilities in urban areas. For instance in a suburban or an arterial environment filling station advertising displays are perfectly adequate to indicate the position of this service facility.** In terms of developing the tourism signing component of an Urban Signing Plan (see Figures 9.12 and 9.16) the philosophy of the following basic principles should be maintained:
 - (a) large metropolitan areas and other larger towns, which are by-passed by national and the major provincial routes, should co-operate with the national and provincial road authorities in the provision of a basic network of tourism signs, including any necessary follow-up signs, relating to **emergency and basic service facilities** to serve long distance travellers whose need

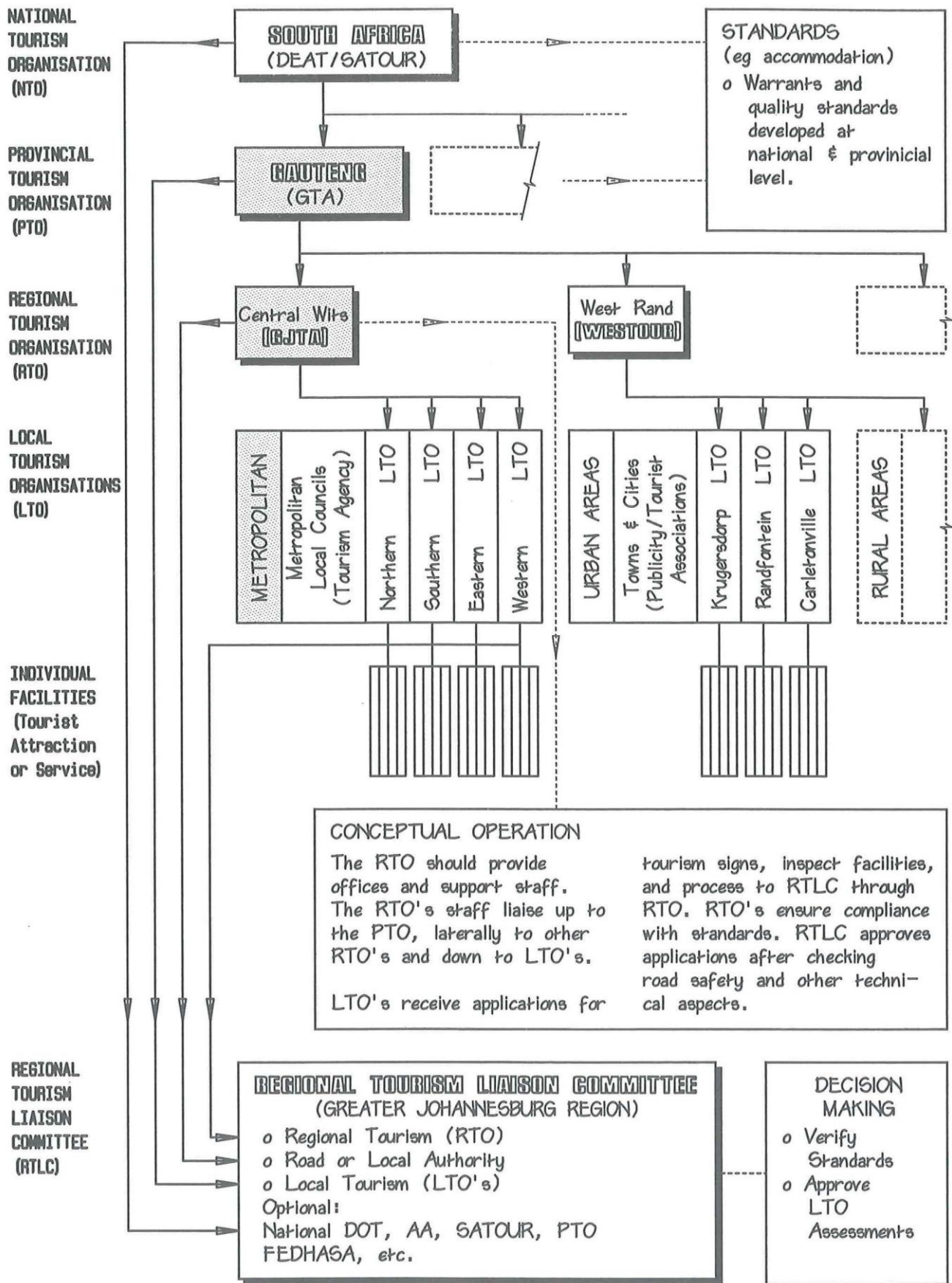

Fig 9.27

Structure of Urban Tourism Organisations and Committees

is either urgent or just in passing;

- (b) otherwise the needs of tourists within large metropolitan areas, and other larger towns should preferably be catered for by a **strategically planned and co-ordinated network of tourist information centres, bureaux or laybys AND the other standard guidance signing components such as numbered routes, orientation destinations and street names;**
- (c) other tourist destinations in metropolitan areas, not covered in terms of paragraph (a), should therefore preferably be dealt with at more remote distances, by tourist information facilities of one sort or another (see Subsection 9.5.9) dealing with regions or areas, and should only be signed, **in accordance with the relevant urban tourism signing warrants, at a local level in the final stages of an approach journey.**
- 2 The effect of the provisions of paragraph 9.5.3.1(a), presuming a national or provincial freeway by-pass route without direct access to service facilities, **should be that the most convenient access for drivers to the desired type of service facility ONLY, are signed.** An ideal arrangement, when a network of urban freeways exists, is that such signs should be located in advance of the first suitable access interchange AFTER passing through a freeway system-to-system interchange. Such a policy should be adopted for each basic direction of travel in the system. The use of SERVICE EXIT SEQUENCE sign GF8 is recommended in such complex freeway circumstances. The availability of direct access rest-and-service areas is likely to increase within metropolitan environs on freeway networks, and these obviously offer passing drivers the best option in terms of convenience and speed of service.
- 3 The effect of the provisions of paragraph 9.5.3.1(b) should therefore be a reliance on the use of brown background tourist signs displaying the tourist "i" symbol GFS B5-8. These should be provided in co-ordination with the National and/or Provincial Tourism Organisations who will have guidelines for the provision of adequate tourist information and will inspect and approve appropriate facilities.
- 4 The effect of the provisions of paragraph 9.5.3.1(c) should result in the provision of specific tourist destination signing at a consistent level in the urban street hierarchy, namely a local level, irrespective of the size of the urban area.
- 5 TOURIST DIRECTION signs provide tertiary level information (see Figure 9.22). As a group, the information they provide must be considered in the context of the level of information also provided by DIRECTION and LOCAL DIRECTION signs at specific sites. **It is not good practice to exceed the design criteria for the transfer of information** (see Volume 1, Chapter 4, Section 4.4). For orientational ADVANCE DIRECTION signs to function effectively, it is recommended that a sign stack should be provided for each exit path from a junction i.e. for a crossroad junction this means a stack for the straight-on direction and one each for the right and left turn directions. **Since TOURIST DIRECTION signs do not have an orientational function, stacks should only be provided for those directions serving warranted tourist destinations.**
- This principle is the same as that used for LOCAL DIRECTION signs.
- 6 On the approaches to a Class "B" junction, ADVANCE TURN tourism signs GF2 and ADVANCE LOCAL DIRECTION signs GDL1 may be located at two-thirds and one-third of the distance from the junction respectively, which would be appropriate for an ADVANCE DIRECTION sign GD1.
- 7 TOURIST FINAL TURN signs GF3 should normally only be located at the final turn towards, or at or opposite the point of access, to the tourist destination (see Figures 9.34 to 9.36).
- 8 It is likely that there will be a demand for both TOURIST DIRECTION and LOCAL DIRECTION signs at many junctions. **This will add to driver workload when all signs are required, and this aspect must be taken into account in the design** (see Volume 1, Chapters 1 and 4). Therefore, if tourist AND local direction signs are warranted at a junction, signs may preferably be provided in one of the ways indicated below, namely:
- (a) by combining the two sign types on common supports so that the total sign message of the tourist and local destination signs is within the limits stated for a single sign, and locating the combined signs at "two-thirds GD1" distance from the junction; OR
- (b) by designing a composite sign with the tourism message displayed as an "insert" panel on the ADVANCE LOCAL DIRECTION sign GDL1, also located at "two-thirds GD1" distance;
- PROVIDED that if the GD1 sign is not already in place, the position allocated for it from the junction should be increased by 50% if at all possible, and the distances of the supplementary sign be increased accordingly (see Figures 9.23 and 9.25).
- 9 If tourist destinations require to be signed at a junction in more than one direction the messages applicable to each direction shall be given in sign stacks, each mounted as a separate stack on common support poles so that a right turn stack sits above a left turn stack. **This principle of the separation of stacks is unique to TOURIST DIRECTION signs** (for signface display rules see Subsection 9.5.5 and Chapter 4: *Tourism Signing*, Section 4.3, Figures 4.11 to 4.15).
- 10 If a street carrying high volumes of traffic generated by tourist destinations intersects another street which leads to several tourist destinations an attempt must be made to find group descriptions for the destinations to reduce the display demand. This may take the form of symbols plus SINGLE identifying names. (NOTE: the most likely solution to this problem should be the display of the appropriate collective name as a destination on the normal DIRECTION sign system, since, by virtue of its importance or familiarity it is likely to have orientational value - such a name may commonly be the name of the suburb in which all the tourist destinations are located.)
- 11 Once a tourist destination has been signed, the principle of message continuity shall be applied so that it is signed through subsequent changes of direction until the destination is reached. (NOTE: for this reason straight-on tourist direction stacks are not normally recommended unless the street concerned is lengthy and/or is a cul-de-sac.)

- 12 A limit of 8 "bits" of information should be applied to any combined TOURIST/LOCAL DIRECTION sign. If separate signs are used each should be limited to 6 "bits" of information (NOTE: This provision will, particularly in combination with DIRECTION signs, potentially allow very high levels of information to be displayed. Such high levels of information should not be permitted if all other relevant design factors are not of the highest order i.e. a sub-standard letter size is specified - see Volume 1, Chapter 4).
- 13 Subject to the limitation on the number of "bits" of information given above, the maximum number of destination names which may be displayed on any TOURIST DIRECTION sign or combined TOURIST/LOCAL DIRECTION sign shall be four names.
- 14 If more than one destination name is to be placed on a TOURIST DIRECTION sign stack, it is recommended that, where possible, the order of appearance of the destination names should be such that if one destination is reached before another it should be above the other, OR if a turn comes up first which leads to one destination, that destination should appear above the other.

9.5.4 Classification

- 1 In order to successfully implement urban tourism signs it is recommended that a disciplined approach be followed. It is necessary, in order to work in a disciplined way, to have available a well-structured classification of tourist destinations, so that applications from facility operators can be assessed in a standard way in terms of a range of recognised types of activity, attraction or service. Classifying applications in this way, according to destination type, will also make it possible for the relevant RTLC, on which the road authority is represented, to allocate the appropriate symbol for use on approved signs.
- 2 It is possible that an applicant, or the assessing official, may feel that there is more than one option for classification. In general it is recommended that, wherever possible, the most generic classification be used since this is likely to result in the use of a more easily recognisable tourism symbol on the sign. In this context, if a facility offers more than one activity, attraction or service the applicant should be required to choose which one is most appropriate for classification purposes (see Subsection 9.5.33).
- 3 To assist the classification process tourist attractions have been organised into generic or "family" groupings. Table 9.2 illustrates this classification and each symbol is illustrated with the appropriate warrants in Subsections 9.5.15 to 9.5.32.

9.5.5 Signface Design Principles

- 1 The general principles relating to guidance signface design and layout are covered in Volume 1, Chapters 1 and 4. TOURIST DIRECTION signface design rules have been summarised in diagrammatic form in Chapter 4: *Tourism Signing*, in Figures 4.11 to 4.16. Only the most basic principles are therefore repeated here.
- 2 The signface design principles for TOURIST DIRECTION signs are essentially the same as those developed for LOCAL DIRECTION signs. TOURIST DIRECTION signface design places a high reliance on bold SYMBOLS to transfer the main

part of the message to road users. When the PRIMARY name of a destination is also used it is used to qualify the reference of the symbol. The vertical signface dimensioning is related to these symbols rather than the text. The height of each symbol is capable of supporting two lines of text without increasing the vertical height of a sign or sign stack. Two techniques are therefore recommended to further contain TOURIST DIRECTION sign sizes when text is involved. These techniques are:

(a) if the PRIMARY name is a two or more part name-

e.g. "Gold Reef City" (mine)

then the name could be placed in two lines in a right-justified form -

e.g. **Gold Reef
City**

(b) if the PRIMARY name is long and can be satisfactorily hyphenated without risk of loss of meaning or readability, then the primary name should be hyphenated and placed in two lines in a right justified form -

e.g. **Suikerbos-
rand** or **Makgadi-
kgadi**

When, for ease of the arrangement of words, the lower line of text becomes longer than the top line, then the text should be left justified. Two or more lines of text referring to two or more destinations of a common type (i.e. two hotels) should be left justified.

- 3 The preferred signface display comprises a SYMBOL indicating the category of tourist facility (see Table 9.2). According to warrants, certain facility types may also display the PRIMARY name of the destination, always to the right of the symbol irrespective of the direction in which the sign is pointing (this combination of symbol and primary name is mainly reserved for tourist attraction and accommodation facilities). Details of the warrants are given from Subsection 9.5.10 onwards. The principles behind this type of display are:
- (a) to provide early recognition of the facility type by means of the symbol (generally, tourist service destinations and Afollow-up@ signs display a symbol, or symbols, only);
- (b) to limit the size of a text message;
- (c) to limit the total message display the primary name is that part of the name of the facility, which when combined with a Ageneric@ category symbol describes the specific facility being signed - avoiding the use of additional common terminology such as museum, stadium, dam, park etc.
- Text only messages may be used if it is felt that there is no suitable symbol, however, this situation should rarely arise due to the availability of the family or Ageneric@ class symbols, use of which is encouraged.
- 4 A TOURIST DIRECTION sign, as with any other road sign, shall be legible. However, the principle used in the tourism signing system is to, generally, use one letter size smaller than

used on the normal DIRECTION signs in the same environment. For urban applications this rule should be subject to a normal minimum letter size on TOURIST DIRECTION signs of 175 mm /125 mm. A letter size less than 140 mm / 100 mm shall not be used. Internal spatial dimensions are also reduced compared to those used on DIRECTION signs. The use of these standards means that signs are commonly 20% to 30% more compact than DIRECTION signs, which is considered acceptable in terms of the supplementary role of TOURIST DIRECTION signs.

- 5 The use of DIN 1451 Style "B" lettering is recommended. Consideration may be given to the use of DIN 1451 Style "A" lettering in low speed urban environments.
- 6 TOURIST DIRECTION signs may include straight-on, right-turn and/or left-turn stacks, although the use of straight-on stacks is not common (see paragraph 9.5.3.11). An individual stack may be divided into up to three panels by internal border lines, subject to a total display not exceeding three stacks or a combination of four stacks/panels i.e. two stacks, one with three panels is acceptable, subject to the total amount of information (see paragraph 9.5.3.12). For right-turn and left-turn stacks the right and left sides of the respective signs are cut-back to slope inwards from top to bottom at a rate of 2 horizontal to 5 vertical (for examples of tourism signface designs see Figures 9.2 and 9.3).
- 7 Since TOURIST DIRECTION signs are commonly used in supplement to DIRECTION signs on which navigational route numbers are displayed, such route numbers shall not normally be displayed on TOURIST DIRECTION signs, unless the only destination in the direction in question is a tourist destination, and the road is a numbered route. The display of a route number is only likely to occur in an urban environment if the route has been numbered as a tourist route.
- 8 Aesthetic signface design rules include the requirement that the lengths of right-turn and left-turn stacks (and a straight-on stack, if used) mounted on common supports shall be such that all stacks shall be of equal length irrespective of stack or panel message length. To further enhance signface aesthetic treatment, where possible, it is recommended that symbols in different stacks or panels be aligned vertically on the centre lines of the symbols and that the first letters of any primary names be left justified (subject to the effects of any two line displays - see paragraph 9.5.5.2).
- 9 If a destination is located same distance beyond the final turn towards it, a distance may be included on the GF2 or GF3 sign. This treatment is not likely to be common in urban areas but can occur fairly frequently in "peri-urban" areas. The distance, given to the nearest 100 m, should be located below the destination name and right justified on it. The distance numerals should be followed by the letters "m" or "km" as appropriate.
- 10 When the tourist destination is at the end of the road and it is the only public destination, such a destination may be included in the stack of a DIRECTION sign provided for the junction in question, either within a brown "insert panel" or a brown stack (see Volume 1, Chapter 4, Subsection 4.11.10).

- 11 The various signface design principles described in this section are specifically dimensioned for TOURIST DIRECTION signs in Volume 4, Chapter 7.

9.5.6 Symbols

- 1 TOURIST DIRECTION sign symbols are sized according to the same dimensional criteria as LOCAL DIRECTION sign symbols, with a nominal design height and width of 15"d", where "d" is the letter stroke width used on the sign (and the letter height is 7"d"). The length of a symbol should not exceed 25"d and the height should not exceed 15"d.
- 2 A tourism symbol is sized so that it may, if necessary support two lines of text within a stack or panel without a need to further increase the height of the stack or panel. When a symbol is used with text it shall always be located to the left of the text. The text may comprise any of the following options:
 - (a) a single PRIMARY name in one line centred vertically to the right of the symbol;
 - (b) a single PRIMARY name in two lines to the right of the symbol (see paragraph 9.5.5.2);
 - (c) two PRIMARY destination names of the same type (in the same direction) to the right of the symbol;
 - (d) three PRIMARY destination names of the same type (in the same direction) to the right of the symbol.
- 3 If a symbol should need to be used with three PRIMARY names representing three destinations of the same type in the same direction, then the symbol size should be made "oversize" by one standard increment in the value of "d" i.e. from 20 mm to 25 mm, or 30 mm to 40 mm.
- 4 Symbols shall not be used on TEMPORARY FACILITY tourist sign TGF17.
- 5 Wherever possible, sign designers should try to use the generic family symbols identified for the sub-groups of tourist attractions (see Table 9.2 and Chapter 4, Section 4.3, Subsection 4.3.10). Adherence to this recommendation will make the learning of the more important symbols more effective. If the need arises for a symbol which is not documented, or cannot be covered by the principle indicated above, the designer or manufacturer shall make this need known, with a sketch proposal, to:

The Secretary
Route Numbering and Road Traffic Signs Sub-Committee
c/o Department of Transport
Private Bag X193
Pretoria
0001.

9.5.7 Shape, Size and Colours

- 1 TOURIST DIRECTION signs shall be rectangular in shape, horizontal in format and with a cut-back vertical side in the direction of turn, with the exception of the part-time facility FINGERBOARD type sign which shall have one side shaped to a point.

PERMANENT TOURISM SIGNS

TOURIST ATTRACTIONS - GF1/GF2/GF3 Signs

Group A1 National Parks <ul style="list-style-type: none"> National Parks 	Group A2 Provincial Parks <ul style="list-style-type: none"> Gauteng Free State Western Cape Kwazulu Natal Eastern Cape Northern Cape North West Northern Province Mpumalanga 	Group A3 Resorts <ul style="list-style-type: none"> Country Club Hot Springs Inland Water Seaside/ Beach Berg/ Mountain 	Group A4 Scenic <ul style="list-style-type: none"> Nature Reserve Natural Heritage Botanical Gardens Gardens (flower) Waterfall Lake or Dam (no water-sport) Caves Viewpoint Forest (natural) State Forest Mountain/ Berg 	Group A5 Sports <ul style="list-style-type: none"> Motor Racing Golf Course Equestrian Fishing Cricket Field Swimming Pool Sports Stadium 	Group A6 Wildlife <ul style="list-style-type: none"> Conservancy Area Game/Farm Reserve Bird Park Zoo Snake Park Crocodile Park Rhino Park Lion Park 	Group A7 Historical <ul style="list-style-type: none"> National Monument Museum Historic Mine Historic House Historic Railway Historic Battlefield Historic Cemetery Geological Site 	Group A8 Coastal <ul style="list-style-type: none"> Marine Reserve Maritime Museum Aquarium Whales Dolphins Light House Dockyard Boat Launch Fishing Crayfish Oceanarium Beach 	Group A9 Arts & Crafts <ul style="list-style-type: none"> Painting & Drawing Pottery Jewellery Weaving & Knitting Leatherwork African Arts and Crafts Woodwork Metalwork 	Group A10 Cultural <ul style="list-style-type: none"> Theatre Amphitheatre 	Group A11 Adventure <ul style="list-style-type: none"> Hiking Trail Horse Trail 4x4 Trail Bike Trail River Rafting Scuba Diving Ballooning 	Group A12 Agricultural <ul style="list-style-type: none"> Wine Cellar Wine Route/ Estate Showground Cherry Farm Ostrich Farm with riding Ostrich Farm Fish Farm Butterfly Farm 	Group A13 General <p>Any attraction not covered by an individual attraction in Group A1 to A12.</p> <ul style="list-style-type: none"> Animal Theme Park
---	---	---	---	---	---	---	---	---	---	--	---	--

SERVICES - GF1/GF2/GF3 Signs

Group B1 - Emergency Services <ul style="list-style-type: none"> Telephone Police Hospital First Aid SOS Phone NSRI Ambulance Fire Station Cell Phone 	Group B2 - Light Vehicle Services <ul style="list-style-type: none"> Filling station & Workshop Filling Station Workshop Tow-in Service 	Group B3 - Truck Rest & Service <ul style="list-style-type: none"> Truck Service Area 	Group B4 - Food Services <ul style="list-style-type: none"> Restaurant Refreshments Take-away 	Group B5 - General Services <ul style="list-style-type: none"> Parking Area Toilets Shower Drinking Water Fireplace Cooking Facility Picnic Area Tourist Information Handicapped Person Facility Roadside/ Curio Stall Post Office Rural Shop 	Group B6 - Rest & Service Areas <ul style="list-style-type: none"> Rest Area - Class 1 Rest Area - Class 2 Service Area - Class 3 <p>PLUS D1 - "Totem Signs"</p> <ul style="list-style-type: none"> Motor Cars Caravans Buses Trucks Motor Cycles Take-away Restaurant Refreshments Shop Facility for Handicapped Persons Toilets Straight-on Arrow Left/Right Arrow Diagonal Left/Right Arrow Advance Left/Right Arrow Exit (Route Number) Parking Filling Station & Workshop Filling Station Picnic Area Tourist Information Motor Car Wash Truck Wash Drinking Water Fireplace Cooking Facilities Shower 	Group B7 - Vehicle Class <ul style="list-style-type: none"> Motor Cars Caravans Buses Trucks Delivery Vehicles Motor Cycles
---	--	---	---	--	---	--

ACCOMMODATION - GF1/GF2/GF3 Signs

Group C1 - Accommodation	
<ul style="list-style-type: none"> Hotel, Motel, Inn Chalet Caravan Site Camp Site Guest House 	<ul style="list-style-type: none"> Bed & Breakfast Rooms Youth Hostel Trail Shelter Guest Farm

PART-TIME ATTRACTIONS - GF17 Signs

REGULAR EVENTS / FIXED VENUE			IRREGULAR EVENTS
SEASONAL	MONTHLY	WEEKLY	PERMANENT VENUES
eg. Flower show	eg. Rambles Flea Markets	eg. Flea Markets	eg. Conferences Training Courses

TEMPORARY TOURISM SIGNS

SPECIAL EVENTS - TGF17 Signs

- Sport
- Shows
- Conferences
- Auctions
- Open Days
- Tournaments
- Festivals
- Galas
- Fetes
- Rallies
- Projects

NOTES:

(1) From time to time additional tourist destination types may be added. This table illustrates the approved groupings with typical examples but will not be updated regularly.

(2) The order of facilities in these lists does NOT imply any priority or importance. If space for a sign, or on a signface, is limited, the indication of Emergency Services should take priority over all other options.

Table 9.2
Classification of Tourism Destinations for Signing Purposes

- 2 The size of TOURIST DIRECTION signs is dependent on the symbol and destination messages to be displayed and the choice of letter size to be used (see Volume 1, Chapter 4, Section 4.3 and Volume 4, Chapter 7).
- 3 TOURIST DIRECTION signs shall have a brown background colour with white symbols, text, arrows and border. A limited number of symbols, primarily in the emergency service class, are multi-colour symbols. TOURIST DIRECTION signs are not provided in temporary colours, with the exception of TEMPORARY FACILITY sign TGF17 used for signing short term tourist attractions. The colours of TGF17 signs shall be a black background with yellow text and border.

9.5.8 High Density Tourism Areas/Tourist Routes

- 1 HIGH DENSITY TOURISM AREAS (HDTA) have commonly, to date, tended to develop in peri-urban areas around the greater metropolitan areas in South Africa, although this does not mean that the conditions relevant to the development of an HTDA cannot occur in the vicinity of smaller urban areas. A summary of the signing criteria for the creation of an HDTA is therefore included in this chapter (for greater detail see Chapter 4). During the development of the Guidance Signing Plan the potential for one or more areas to be treated as HDTA's may be identified. Due to the relative complexity of such areas, identification of the scope and limits of an area will normally require a specific study. A HIGH DENSITY TOURISM AREA can be defined by the following statement :<R>the complexity of multiple routes and the proliferation of demand for individual tourism signs exceeds the capability to supply signs conforming to agreed guidance signing principles within a definable area@.<R>In terms of the normal rules applicable to the provision of supplementary TOURIST DIRECTION signs, the sort of complexity which could exist in an HDTA could mean that any attempt to deal with the demand conventionally, would, almost certainly result in a chaotic number of signs, at considerable expense, and in such a way that by their very numbers, the signs would be ineffective. The challenge therefore is to design a systematic guidance signing scheme for a specific area which can satisfy the demands, without incurring high costs or creating a chaotic situation.
- 2 TOURIST ROUTES are formally numbered routes. As such they effectively take the "nearest" numbered route closer in the road hierarchy to many tourist facilities. The principle effect of numbering a TOURIST ROUTE is that, at the turn off from a numbered navigational route, i.e. R44, **it is only necessary to provide a TOURISM sign identifying the route.** This sign will normally display the tourist route number in yellow, a theme symbol (e.g. scenic, mountains, coastal etc.) and the route name which may be unique or be the same as the theme. This will be significantly less information for drivers to absorb than individual signs to all facilities along the route. This approach may be relaxed if emergency facilities exist on the route. The information relating to any emergency facilities should be given in a separate panel below the route description. TOURIST ROUTES may commonly be warranted within a HIGH DENSITY TOURISM AREA. Additional signing may be necessary to provide route continuity or where two TOURIST ROUTES intersect. It is also

anticipated that the manner in which many identified HDTA's will be used by the public is in a very informal meandering way. It is quite likely under these circumstances that tourists may lose their bearings and require relatively frequent reassurance as to where they are. Consistent with the objective of limiting total sign area within the system, whenever practical, the concept of utilising compact TOURIST ROUTE MARKER guidance signs, GE18, is worth considering. Since certain roads within a high density tourist area could be recommended to be designated as tourist routes, it becomes relevant to consider using TOURIST ROUTE MARKER signs. Such signs should display the tourist route number and the theme symbol for the area, and can be used for route confirmation purposes. They can also be used instead of the much larger GF2 or GF3 signs at junctions of two tourist routes (see Figures 9.2, and 9.28 to 9.30).

- 3 A TOURIST ROUTE can also be established over an existing numbered navigational route. In this case a tourist route number is not allocated. The route is identified by supplementary TOURISM signs giving the route theme symbol and route name. TOURIST ROUTE MARKER signs may also be used for such an application. This type of tourist route is less likely to occur within an urban area, but the criteria remain relevant if a potential need is identified.
- 4 In any area concerned with developing tourism, there will be a maturing process as facility owners become more and more commercial and they seek new ways of attracting visitors. One of these ways will be the request for tourism signs, and the Regional Tourism Liaison Committee, which includes representation from the road authority, must manage those applications effectively (see Subsection 9.5.2). The following list describes how a tourist area might develop:
 - (a) seasonal - once per year;
 - (b) restricted hours - variable or limited opening times;
 - (c) low density - isolated clusters of attractions;
 - (d) medium density - groups of clusters of attractions;
 - (e) high density - area-wide attractions.
- 5 The preparation of a Guidance Signing Plan will have already established a consultative process with role-players of influence. When considering the possibility of establishing a HIGH DENSITY TOURISM AREA or a TOURIST ROUTE the consultative process must be extended to role-players specific to the area in question. In a similar way to the development of the Guidance Signing Plan (see Figures 9.12 and 9.16), it is essential to explain the signing principles and constraints to the role-players. As part of the subsequent study the following information should be gathered (details of the existing guidance signs, and any deficiencies these may have, will already have been recorded as part of the work on the Guidance Signing Plan):
 - (a) an inventory of existing tourism facilities and services;
 - (b) a quality assessment of the facilities;
 - (c) classification of the facilities as full-time or part-time;
 - (d) classification of facilities according to Table 9.2;
 - (e) determine the potential for growth in tourism activity;
 (continued on page 9.5.12)

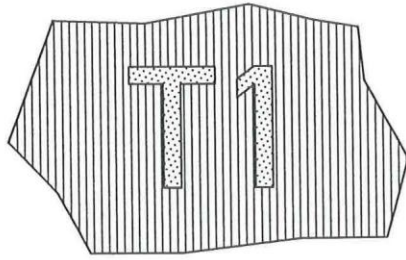

Detail 9.28.1 Tourist Route Number Indication

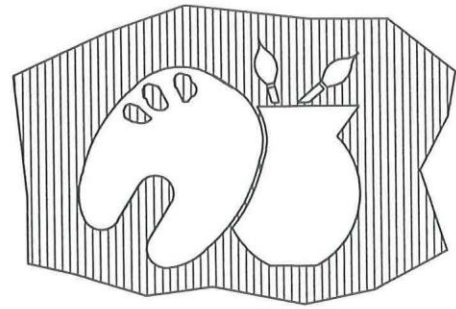

Detail 9.28.2 Generic Theme Symbol for Area

Crocodile River Ramble

Detail 9.28.3 Unique Collective or Theme Name (Maximum of 3 words)

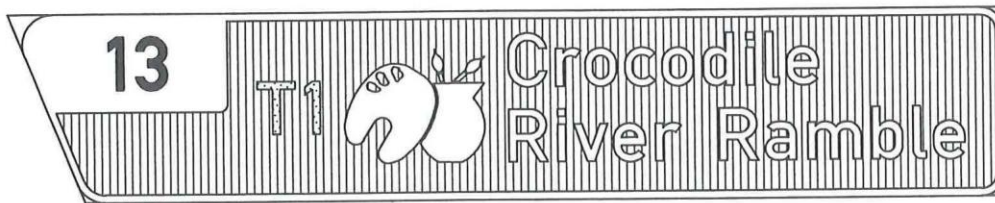

Detail 9.28.4 Typical Sign at Main Point of Entry to Tourist Area (GF1 example being from a freeway to an entering crossroad)



Detail 9.28.5 Typical Sign GF2 Indicating a Numbered Tourist Route From a Numbered Navigational Route



Detail 9.28.6 Typical GL6 Location at Gateway to Tourist Area

R

Fig 9.28

Tourist Route or Area Signing Signface Elements and Typical Signs Used at Entry Points or Gateways

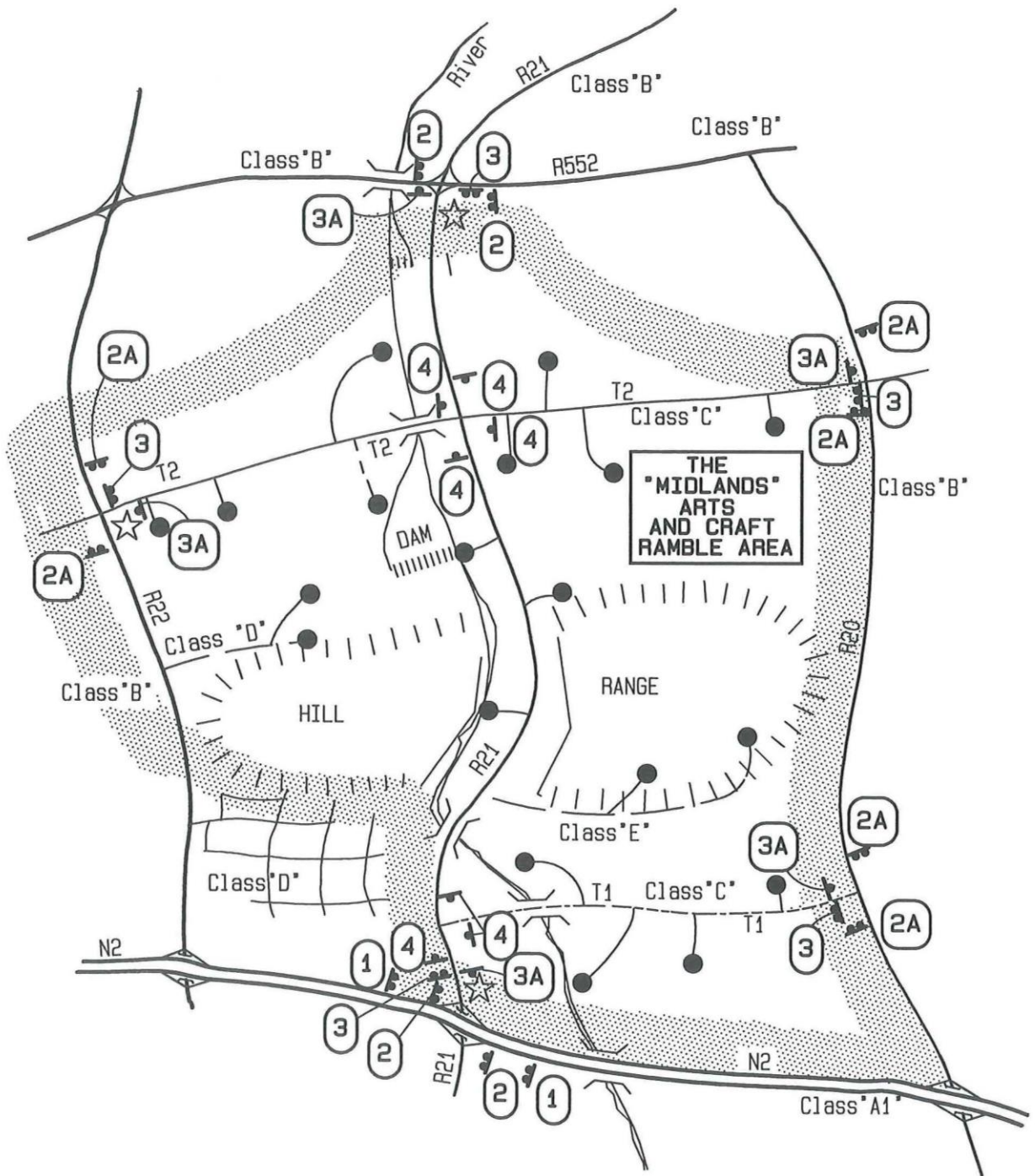

KEY:

- Surfaced Roads.
- - - Gravel Roads.
- Tourist Facility or Attraction.
- ☆ Possible Information Agent or Layby.

- N2 Numbered Roads.
- R20 (NATIONAL, PROVINCIAL, REGIONAL, METROPOLITAN)
- T1, T2 Tourist Routes (Un-numbered Routes)

Note:

Direction signs may also be required/provided at certain Junctions.

Fig 9.29

Signing a High Density Tourist Area with Similar Theme Tourist Routes (see Figure 9.30)

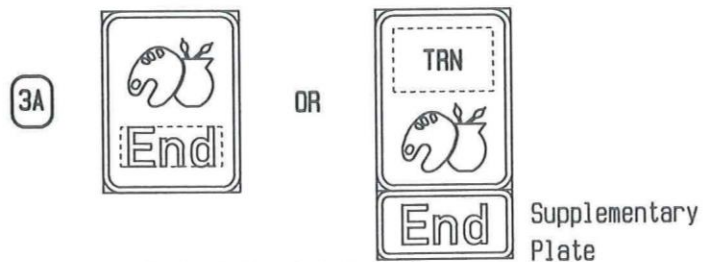
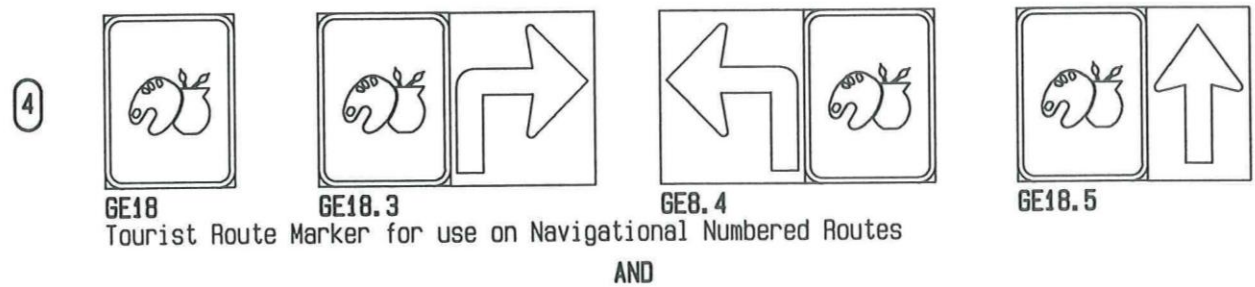
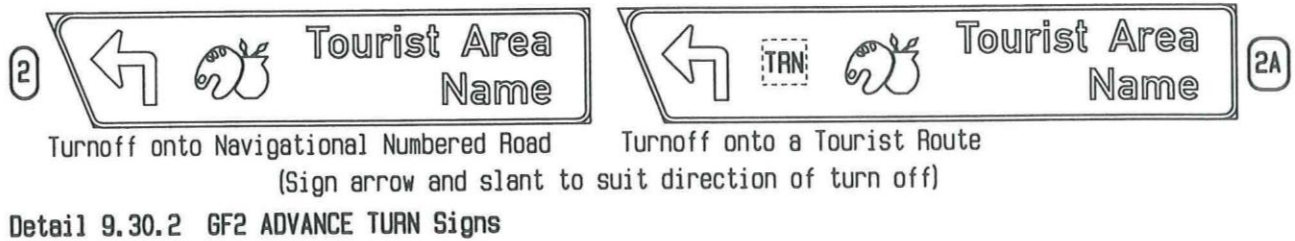
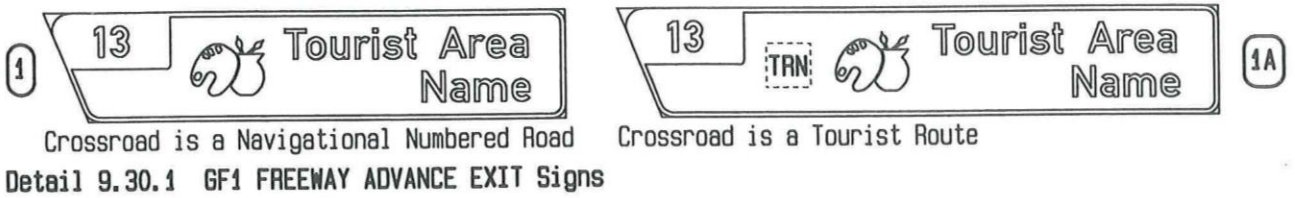

NOTES :

1 TRN = Tourist Route Number.

2 4 = Sign no.- refer to Figure 9.29.

3 • = T-numbers will only be assigned to otherwise un-numbered roads.

Fig 9.30 Tourist Signs Used to Identify a High Density Tourist Area and Tourist Routes (see Figure 9.29)

(continued from page 9.5.8)

- (f) definition of appropriate boundaries to the area;
- (g) assess the need for tourist routes within and/or abutting the area - this has the potential to significantly reduce the overall signing required to achieve a cost-effective plan.
- 6 It is very probable that candidate HDTA's will include significant numbers of part-time facilities. It is normally a prerequisite for the signing of tourist facilities that they are open to the public on a full-time basis (or very nearly full-time). The relevant warrant commonly requires the facility to be open for 12 hours a day for 365 days a year. Part-time facilities can, however, represent the core of tourism activity in an area. A special class of PART-TIME FACILITY sign, GF17, has been allocated for use in signing this class of facility (subject to compliance with certain criteria). This sign has a FINGERBOARD shape, but otherwise follows the same signface rules as other TOURIST DIRECTION signs. It is desirable that part-time facility operators display an additional sign, within their property but clearly visible from the approaching roadway, which should be a changeable sign capable of indicating when the facility is "OPEN" or "CLOSED". The sign may include any unique "Emblem" or "Logo" adopted by the area for "branding" purposes.
- 7 Temporary events are, in essence, one-off part-time tourist attractions, although many of them may be regular annual events. These may be signed using TEMPORARY FACILITY sign TGF17, and the signs are commonly erected and removed by a service organisation such as the Automobile Association. These signs should be truly temporary signs and conform to the black-and-yellow temporary sign colour code. Typical temporary events include (a TGF17 sign is illustrated in Figure 9.2):
- (a) auctions;
 - (b) festivals;
 - (c) fetes;
 - (d) gymkhanas (and other infrequent sporting occasions, etc.).
- 8 There is a general trend towards the provision of multi-function venues. These may have a significant potential to attract visitors, and from a very wide catchment area. Many of these visitors will be unfamiliar with the location of the venue. Consideration may be given to providing such facilities with part-time tourism signs, GF17, because the facilities are not operating all the time, and relying on such signs to guide visitors rather than providing regular TGF17 signs. An alternative to such an approach, in an urban or peri-urban area might be to use a LOCAL DIRECTION sign. The latter would particularly be the case if the events being staged are directed at commercial participation rather than as tourist attractions, although at this level there is no strong argument for one type of sign over the other.
- 9 **One of the main objectives of the planning and development of a tourism signing plan for an area should be to develop some concept which will offer an adequate compromise solution to the various conflicting problems which exist.** In most cases, the possible solution will be at two levels, namely:
- (a) the signing treatment of the whole area; and
 - (b) the signing treatment of individual facilities.
- 10 Throughout the preparation of a tourism signing plan for an HDTA, close attention should be paid to finding ways of reducing the need for large signs or large numbers of signs. The motivation for this approach is to achieve the most effective signing reasonably possible by means of the least possible total sign area, and this for two basic reasons:
- (a) to limit the overall environmental intrusion of the signs (but still have enough impact for them to achieve their purpose); and
 - (b) to limit the total cost of the signs.
- 11 It is an established principle, covered in Volume 1, that signing for an area can be kept within reasonable limits if the area has a uniqueness of identity which can be used on tourism signs (see Figure 9.28), involving:
- (a) a Unique Collective Name - the need for alternative means of displaying tourism information will usually arise due to an "overload of information" at an existing intersection or on an existing tourism sign; in this instance, a pro-active approach is recommended whereby a collective "name" or "identity" is used to replace a number of separate tourism facilities; this option is clearly cheaper than an information lay-by, requiring the usual brown tourism signs only, but it should be facilitated through the local or regional tourism organisations, in consultation with the appropriate tourism stakeholders; the existence of such a tourism body will therefore expedite any discussions and final proposals; to keep sign area down a "collective" name for an area should be kept concise, but should certainly not exceed 2 to 3 words; the name allocated to a tourism area should either be unique to a geographic area or unique to some theme such as historical mining ("Old Digger's Route") or scenery ("Namaqualand Flower Route");
 - (b) Collective Route or Area Symbol - in the context of tourism signing, the other method by which a tourism area should be collectively identified, as "an area", is by means of an appropriate symbol; the symbol can relate to a descriptive representation of the area, e.g. a "mountain" symbol for an area in the Drakensberg, or to an established theme for the principal activities of the area, e.g. a symbol representing "wine", or "arts and crafts" symbol for an area such as the Crocodile River Ramble Area; the symbol should be used together with the full name of the high density tourism area;
 - (c) even if generic tourism symbol(s) can be used with a unique or collective name to describe a high density tourism area, it may still be desirable to identify the area with a unique "Emblem" or "Logo" - such an emblem or logo may be used on an off-road information sign at a layby at the gateway to the area, and at the entrances to individual facilities.
- 12 The use of generic theme symbols such as "arts and crafts", "historic", "wildlife" or "scenic" also has the potential to keep within controllable limits the total numbers of symbols available for use on tourism signs (see Table 9.2). The larger the number of symbols, the greater will be the difficulty experienced by drivers in interpreting them correctly and also in sign

manufacturers supplying the correct symbol. The function of the symbol to allow early recognition of the associated destination, with a minimised need to read words on a sign, will also be eroded by large numbers of symbols, many with distinct similarities.

- 13 Once the limits of an high density tourism area, the road network within the area (including minor roads), and an inventory of candidate tourism facilities and services have been established, consideration should be given as to how to limit the number of tourist signs required at the more important or busy junctions. Many of the minor roads in an area could provide access to three or more facilities or services. It should, therefore, be natural to consider some of the minor roads as "tourist routes".
- 14 In order to keep the system as simple as possible and for such routes to form a logical extension of the existing numbered route system, the use of the designatory uppercase letter "T" is allowed, e.g. "T1" , "T2", etc. A very significant benefit of this approach is that the signs on, for example, a provincial numbered route on the approach to a junction with a numbered tourist route, would display a tourist route number, a generic symbol and the unique collective name. Many such junctions may end up being signed in this manner. In this way, the alternative need to try to indicate a multitude of specific tourism destinations, at such junctions, is avoided at no disadvantage to the driver, or to the facility. This is because an awareness of the tourist route number required to reach a specific facility is a very simple piece of information to promote and acquire. Once on the tourist route, drivers will now expect to see a sign to the specific tourism destination they are seeking. The signface elements for the Crocodile Ramble Area are illustrated in Figure 9.28 as an example of specific signs indicating a tourist route as opposed to a tourism facility.
- 15 In principle, the signs described above should be provided by the road authority as part of the basic navigational Guidance Signing Plan for a high density tourism area.
- 16 The allocation of tourist route numbers and the signing described in paragraph 9.5.8.11 is intended to enable tourists to make what amounts to a "final" turn from a numbered route towards the tourism destination they seek. It is a criterion of the route design process that the number of tourist destinations on such a route should be three or more. This limit is dictated by the norms applicable to tourism signface design.
- 17 It should be noted that, in terms of this criterion, signing of specific tourism facilities or services may still be provided directly from navigational numbered routes, numbered tourist routes and other roads which have not been allocated a number. For most high density tourism areas it is possible to classify tourism destinations into three groups, as follows:
- full-time attractions or services;
 - part-time attractions or services; and
 - temporary attractions or services.

The level of signing should be different for each group and the provision of signs in all cases should be subject to approval after formal application.

- 18 Figure 9.29 shows an area in which two numbered tourist routes have been created, in addition to five navigational numbered routes, four of the latter of which create the majority of the perimeter of the theme area. The signing for this example has been developed according to a concept known as the "Gateway Perimeter" method. This concept involves a significant concentration of the information and signing effort at the main points of entry to the area. Signing at internal junctions between numbered routes, including numbered tourist routes, is limited to TOURIST ROUTE MARKER signs GE18. Because of the likely high number of facilities in the area the "Gateway" method also recommends the establishment of tourist information centres or laybys at the "Gateways". This can be a costly process and requires a high measure of commitment from the tourist operators in the area. The "Gateway" concept is therefore recommended for the most highly developed or concentrated tourist areas.
- 19 In Figures 9.29 and 9.30 the signs shown by number are of the following types:
- (1) - GF1 FREEWAY ADVANCE EXIT signs displaying an interchange number, the tourist area theme symbol and the tourist area theme name (if the route to which the freeway exit leads is a numbered tourist route then the tourist route number should be displayed in front of the symbol);
 - (2) - GF2 ADVANCE TURN DIRECTION signs displaying the tourist area theme symbol and the tourist area theme name (these lead to a numbered navigational route within the tourist area);
 - (2A) - GF2 ADVANCE TURN DIRECTION signs displaying the tourist route number, the tourist area theme symbol and the tourist area theme name;
 - (3) - optional - GL6.3 (TOURIST AREA NAME) GEOGRAPHICAL LOCATION sign to identify the start of the tourist area - see Volume 1, Chapter 4, Section 4.6, Subsection 4.6.9;
 - (3A) - optional - GE18 END OF TOURIST ROUTE/AREA signs;
 - (4) - GE18 TOURIST ROUTE MARKER signs.

9.5.9 Tourist Information Centres, Bureaux or Laybys

- The provision of tourist information about and within an urban or high density tourist area is very important to the overall effectiveness of the signing and operation of the area. Tourist information can be provided in one or all of three ways (see Figures 9.31 and 9.32):
 - (gateway) information centres;
 - information bureaux or agents; and
 - information laybys.
- Gateway information centres may be situated at the entrances to larger tourism areas. These are likely to be major facilities, often (continued on page 9.5.16)

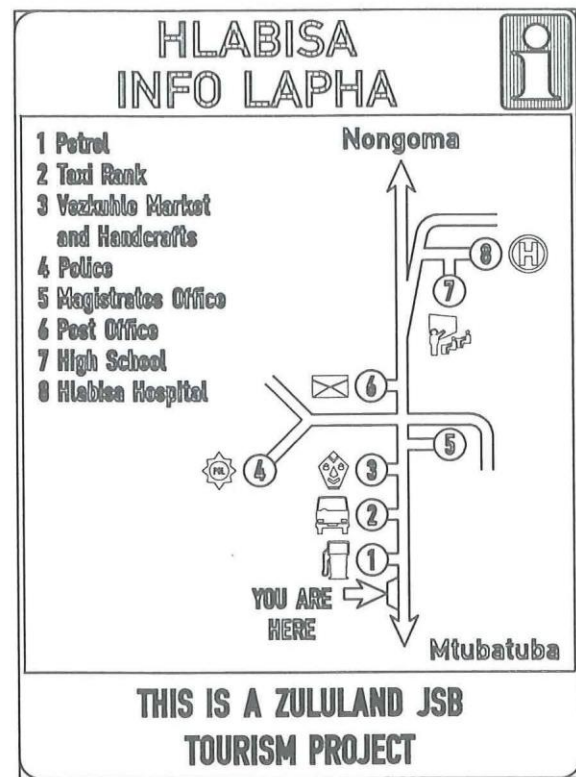

Detail 9.31.1
Conceptual Layout of an Information Board Appropriate to a Small Country Town

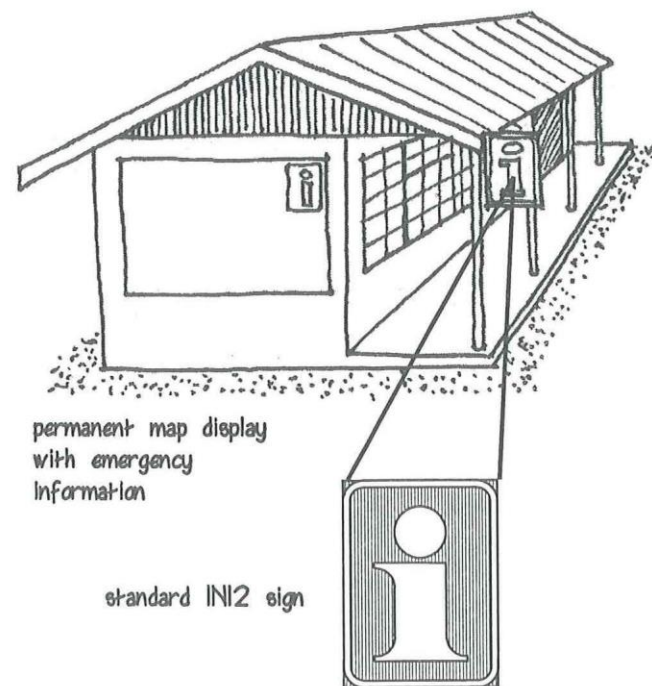

Detail 9.31.2
Small Peri-Urban Store Used to Provide Tourist Information

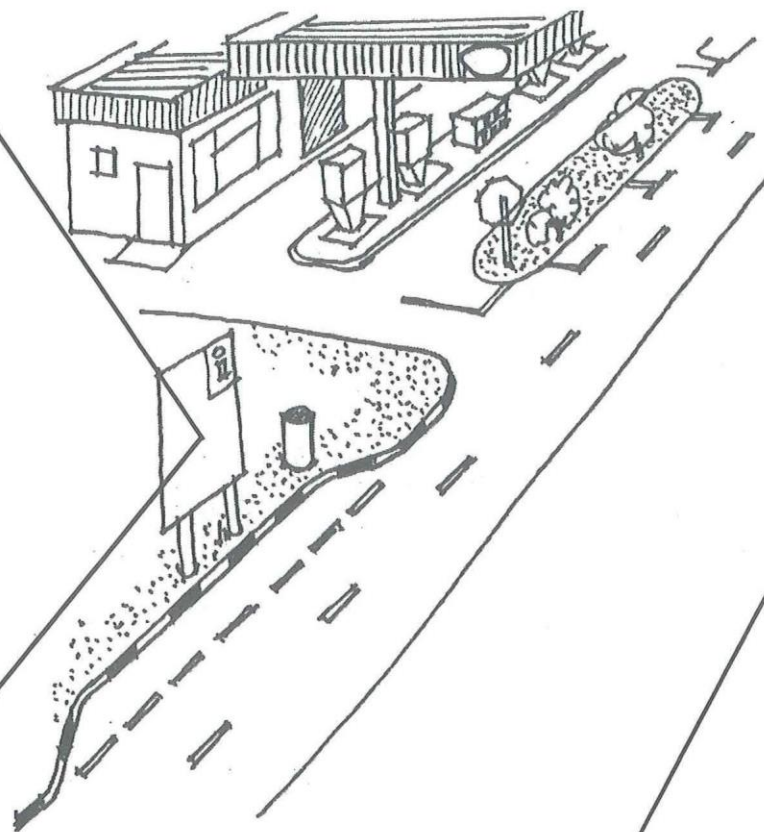

Detail 9.31.3
Basic "Gateway" Information Centre in a Peri-Urban High Density Tourist Area

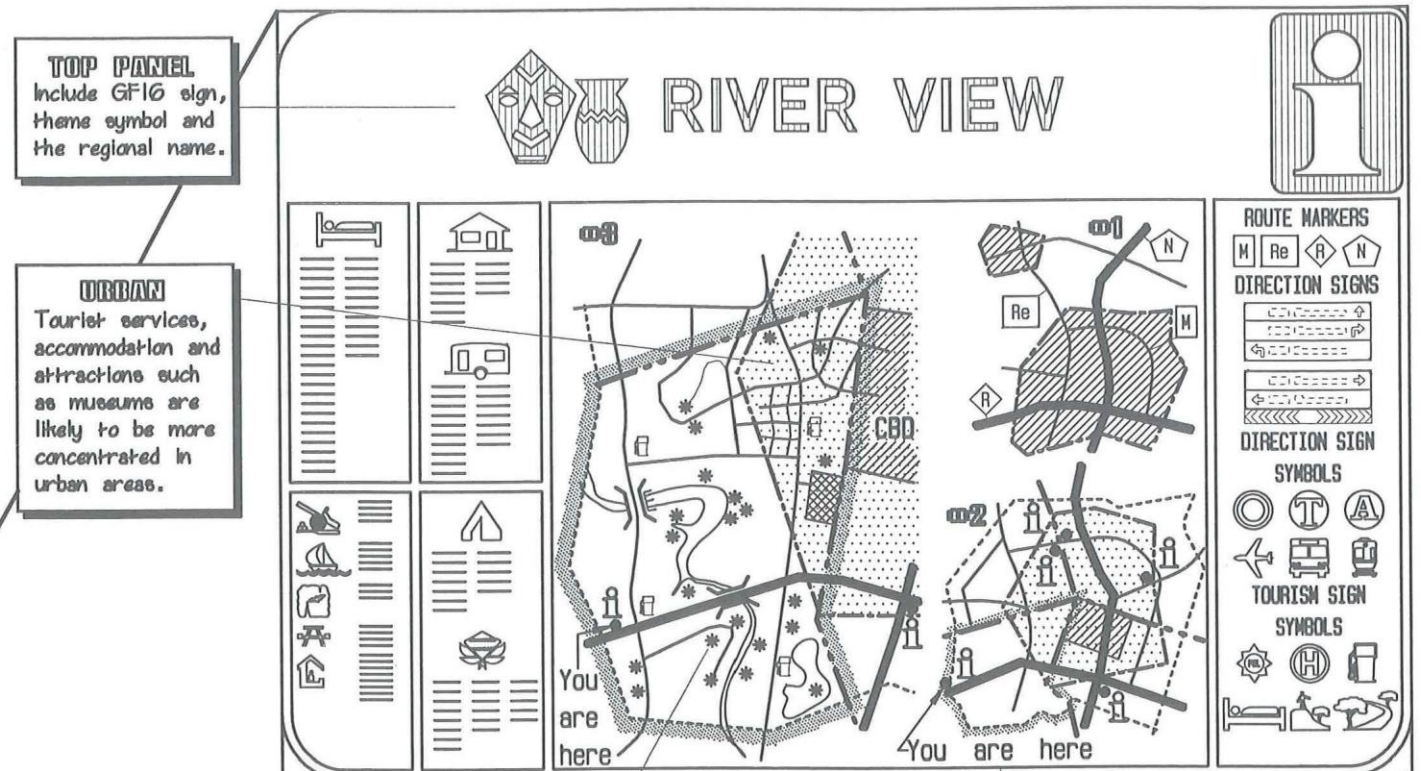
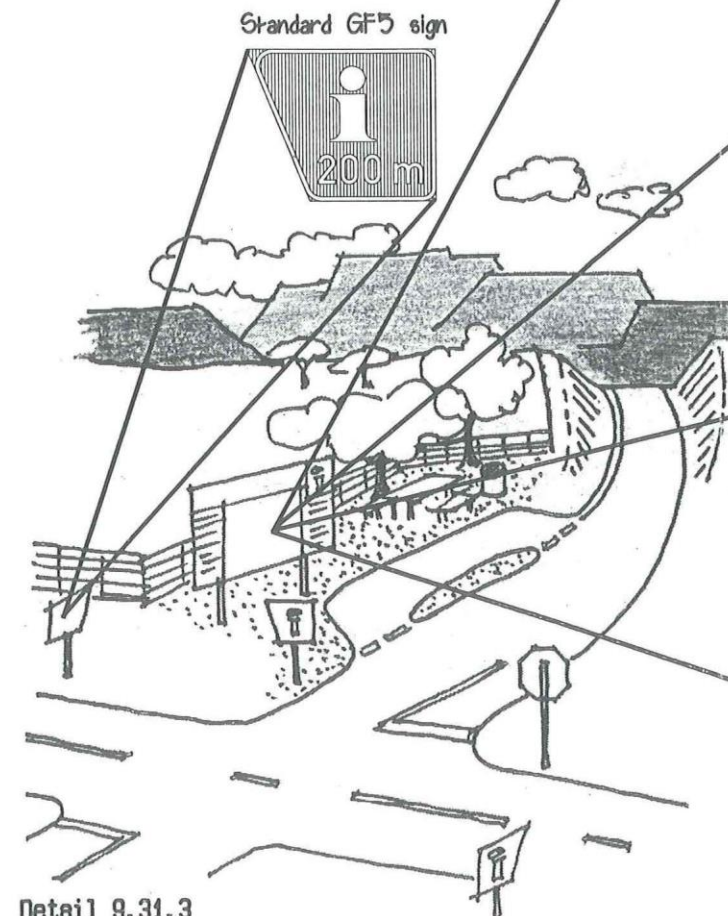

Detail 9.31.4
Conceptual Layout of a Large Information Board Map Shows One Region of a Large Metropolitan Area

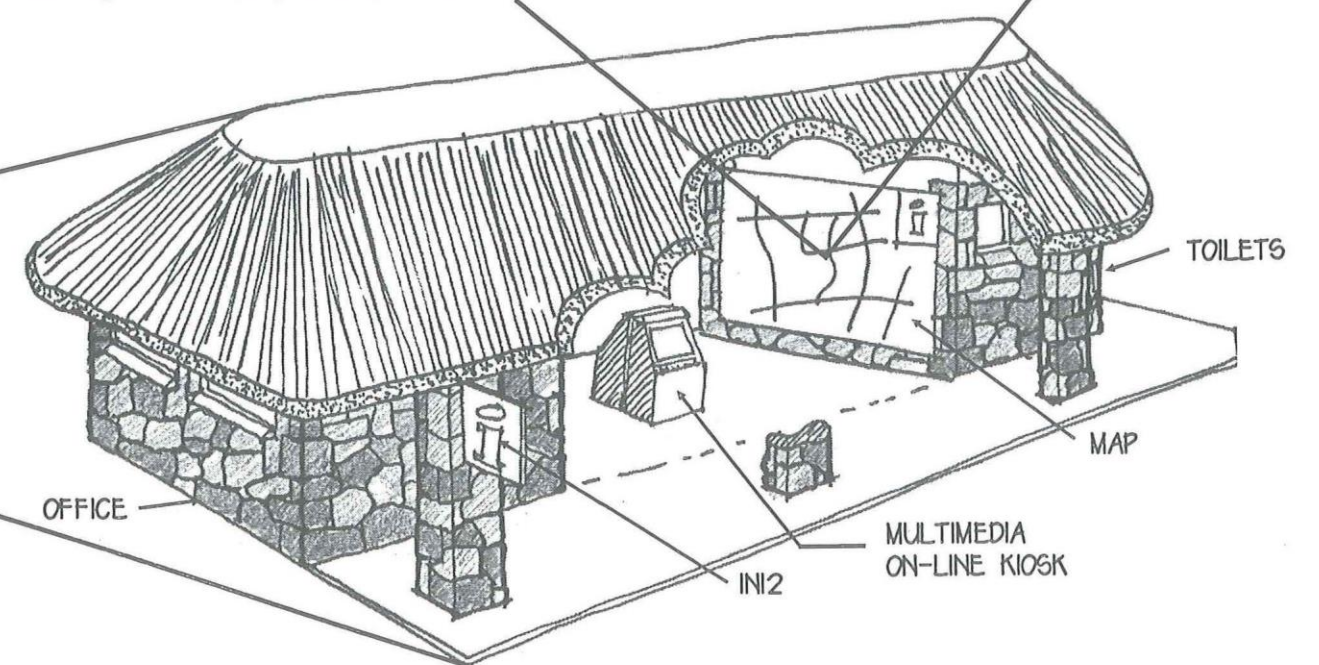

Detail 9.31.5
High Standard Tourist Information Centre Appropriate to a "Gateway" Facility for an Important Tourist Area

Fig 9.31
Urban Tourist Information Facilities - 1

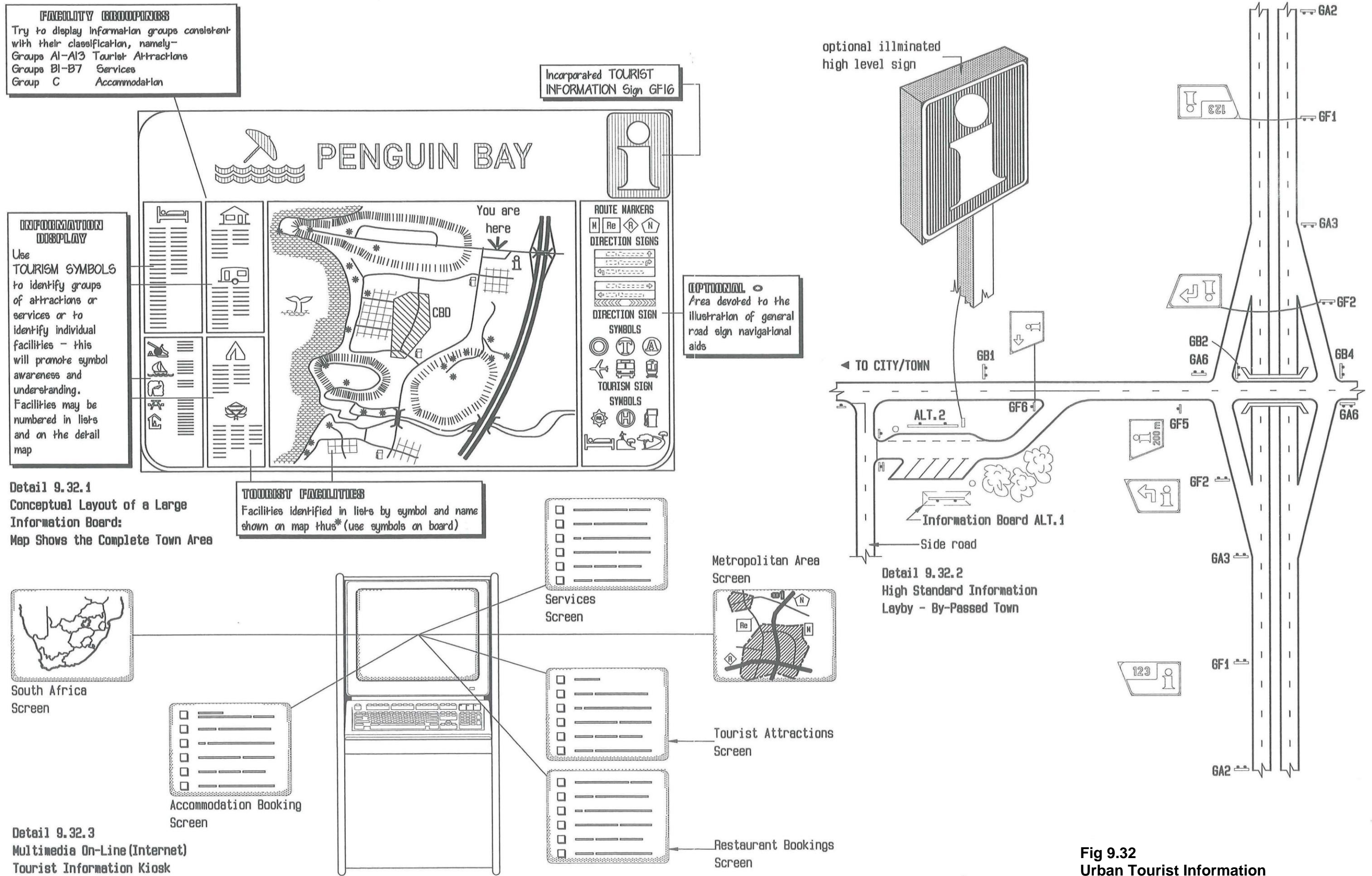

Detail 9.32.1
 Conceptual Layout of a Large Information Board:
 Map Shows the Complete Town Area

Detail 9.32.2
 High Standard Information Layby - By-Passed Town

Detail 9.32.3
 Multimedia On-Line (Internet)
 Tourist Information Kiosk

Fig 9.32
 Urban Tourist Information Facilities - 2

(continued from page 9.5.13)

manned, and for this reason can normally only be provided for on a limited basis. The whole approach to signing a large high density tourism area can, however, be developed around the provision of high quality gateway information centres.

- 3 A whole city or town area can be provided with a network of tourist information centres in a similar way to the "gateway" technique. Opportunities may not always exist, however, to locate the tourist information centres at true "gateways" to the city or town. Larger cities and towns may also require strategically located "in-fill" information centres. This type of approach will limit the number of tourism signs that need to be provided, more or less, to "final turn" type signs, because drivers will be able to navigate adequately until they are relatively close to their final destination, as a result of the information obtained at the centres. The number, size and sophistication of this type of information centre will depend entirely on whether the city or town has a tourism appeal which is:
 - (a) spread evenly throughout the city; or
 - (b) limited to one or two definable areas; or
 - (c) not very highly developed at all.
- 4 A city or town which owes much of its development to tourism appeal is recommended to provide a network of quality tourist information centres, even if the tourism is of seasonal nature. This will limit the demand for individual tourist facility signs. When there are only scattered areas, within or adjacent to the city or town, of tourism appeal, a signing process similar to that used for high density tourist areas is recommended. At the other end of the scale, if tourism is not a significant factor in a town, any tourist information which is relevant can be provided through the local publicity association office or by strategically located layby / tourist information board. It will significantly improve the effectiveness of any tourist information centre or publicity association which is only manned during normal working hours, if it also incorporates a Tourist Information Board, or at least a tourist notice board in the window. These facilities can thereby provide basic information outside working hours.
- 5 It is recommended that the tourism management committee establish a co-ordinated network of information agents by utilising existing service stations, cafes and shops in the area. Such centres of information should be indicated by tourist sign GF17 displaying the TOURIST INFORMATION symbol GFS B5-8. This concept will only be effective if the agents are enthusiastic about their role. If they are only open for limited hours, it will be beneficial if they make sure that basic information, such as emergency contact telephone numbers and a map of the area, are available to view on a 24-hour basis.
- 6 It is also within the of responsibility of the tourism management committee to see that each and every facility in the area acts as a mini information agent, prepared to promote the area as a whole.
- 7 Subject to affordability, the technology exists whereby the centres of information could be fully automated by utilising electronic media tourist information booths which operate in a manner similar to an ATM at a bank.

- 8 Information laybys with map signs of the area may be strategically located so that tourists entering the area can obtain an overview of the area. As an unmanned facility, an information layby can represent a liability of sorts since the information is likely to require regular updating, and such facilities are prone to vandalism.
- 9 It is likely that information lay-byes will need to be self-supporting, i.e. responsibility for updating and maintenance will be for the local/area publicity or tourism body and/or the local authority concerned. However, such facilities, if combined with existing service facilities such as strategically located service stations, or picnic sites or scenic viewpoints, can offer an excellent means to disseminate tourist information.
- 10 The following functions of Tourist Information Boards in an urban environment have been identified:
 - (a) to indicate to road users that they are entering a tourism area of interest;
 - (b) to provide road users with a schematic map of the area so that they may orientate themselves should they be uncertain of their exact location;
 - (c) to indicate where other tourist information offices are in the area;
 - (d) to indicate the locality of the regional tourism office;
 - (e) to promote tourism by creating an increased tourism culture in the area amongst the inhabitants and role players.
- 11 Tourism Information Boards should include:
 - (a) design and detail in a variety of forms; the information board should be colourful and attractive and should utilise the same details as those appearing on the tourism signs, such as symbols;
 - (b) the following information:
 - (i) the Ai@ symbol;
 - (ii) an orientational insert map of the specific area and surrounding areas;
 - (iii) legend describing tourist facilities;
 - (iv) if possible a distance table showing distances between other towns in the region;
 - (v) the "branding" logo of the tourism association or area;
 - (vi) legend A>Welcome to..." with the area name or area.
- 12 The positioning of information boards is one of the most critical elements in order to derive the maximum value and lifespan from such boards. The following factors are relevant and must be considered in the assessment of likely positions:
 - (a) if practical, a favourable background promoting the area – e.g. a scenic view;
 - (b) adequate sight distance before the sign so that there is a sufficient safe stopping distance in order to gain access to the site;
 - (c) favourable gradient for vehicles pulling away from the site;
 - (d) an existing service station or similar site is preferable because of the costs involved in building a dedicated layby, and the time to become operational;

- (e) an undeveloped site with trees is ideal in order to provide shade;
 - (f) vandalism must be borne in mind, and areas where people wait for public transport should be avoided;
 - (g) positions close to intersections should be avoided because of conflicting traffic manoeuvres, which increase the risk of an accident.
- 13 Subject to the layout of any site or layby provided (see Figures 9.31 and 9.32), information boards should be placed, just like normal road signs, at a height of 2 m above ground level and in front of the site. Allowance should be made for at least three cars to be parked at a particular site or layby at any time. This would require approximately 100 m² of parking area. The area should preferably be tarred so that a muddy surface does not deter drivers from parking.
- 14 The positions of tourist information laybys should be clearly indicated using adequately sized LAYBY ADVANCE signs GF5 and LAYBY TURN-IN signs GF6.
- 15 Tourist information boards may be designed to be read either by drivers sitting in their vehicles or by persons outside their vehicles standing in front of the board (or both circumstances). The following guidelines may be of assistance in the detailed design of tourist information boards. (Figures 9.31 and 9.32 show typical information boards that may be used at information centres and laybys):
- (a) letter style - whilst the style of lettering need not be prescribed, the use of clean, uncluttered letter styles is recommended - a typical such style is Helvetica or the DIN 1451 Part 2 letter style; it is recommended that text be displayed primarily in lower case letters, as in normal written text;
 - (b) lower case letter height:
 - (i) 3 mm per metre of viewing distance under good lighting conditions;
 - (ii) 6 mm per metre of viewing distance under a wider range of lighting conditions;
 - (iii) 8 mm or above per metre of viewing distance for greater visual impact or to establish an information hierarchy (i.e. for titles);
 - (iv) the ratio of lower case letter height to uppercase letter height varies from 2:3 to 3:4 according to letter style, the ratio for DIN 1451 Part 2 style lettering is 5:7;
 - (c) symbols - subject to the complexity of symbols involved these should range between 10:7 and 15:7 times the size of upper case letters used on the board (whilst all symbols may not be uniform height, tourism signs symbols have a nominal ratio of 15:7 and guidance sign symbols have a nominal ratio of 10:7 in relation to DIN 1451 Part 2 upper case letters).

9.5.10 Warrants for Signing Urban Tourist Destinations

- 1 Chapter 4: *Tourism Signing* deals with the management of tourism signing applications in Section 4.2. It is recommended that urban authorities familiarise themselves with this topic. Having done so, it is then relevant for the personnel involved to decide how warrants are to be used in the management process. If knowledge and skills regarding tourism signing are limited it is recommended that warrants be applied as firm policy. If a city or town has well developed guidance signing skills, however, then warrants may be considered as not being binding or mandatory procedures, but rather as structured guidelines to simplify the work of the personnel involved. The personnel may even adapt the warrants given below to suite their specific environment. It is recommended that policies and individual variations in practice be documented for training and consistency purposes.
- 2 The details given in Subsections 9.5.10 and 9.5.11 are provided to assist urban personnel, Provincial, Regional and Local Tourism Organisations (see Figure 9.27) and members of Regional Tourism Liaison Committees, with the processing of applications for TOURIST DIRECTION signs in urban and peri-urban areas. However, it is recommended that the application of warrants in an urban environment be subject to the adoption of a policy to implement tourism information centres, bureaux and/or laybys, either singly or as a co-ordinated network of such centres. Subject to the level of implementation of tourist information centres, warrants are applicable as follows to determine:
- (a) whether a facility should be included in the tourist information system; and
 - (b) whether a facility should be provided with FINAL TURN sign GF3 or PART-TIME FACILITY sign GF17, as appropriate; and
 - (c) what rules are applicable to individual signface layout designs; **OR**
 - (d) what TOURIST DIRECTION signs are applicable if information centres are not effectively provided.
- 3 The basic requirement to be complied with in the provision of urban TOURIST DIRECTION signs is that drivers shall have sufficient time, in terms of their environment and driving task demand, to safely take in the additional information being offered by the supplementary sign. **Therefore, if existing primary or secondary DIRECTION signs, and/or existing LOCAL or TOURIST DIRECTION signs require all the available attention of drivers, then the additional TOURIST DIRECTION sign under consideration shall NOT be warranted.**
- 4 **It is a basic hypothesis that, with the aid of tourist maps, brochures and information centres, the existing hierarchy of numbered routes and orientational destinations given on DIRECTION signs, and an adequate system of STREET NAME signs, drivers should be able to reach a point in relatively close proximity to their intended urban tourist destination before supplementary TOURIST DIRECTION signs may be considered necessary.**
- 5 From this hypothesis the provision of tourist direction signs in urban areas should, **irrespective of any individual warrants applicable to the type of tourist destination**, conform to the following principles:
- (a) **tourist direction signs will not be warranted when the location of the destination concerned is obvious to road users, PROVIDED** that, even if the location of the destination is obvious, **if the access to it is not obvious** an appropriate TOURIST DIRECTION sign may be used to identify the point of access;

- (b) the provision of **TOURIST DIRECTION** signs should not commence further from the destination than the nearest numbered route i.e. signing for an individual destination should not occur from one numbered route to another numbered route; however, when a tourist attraction may reasonably be approached from two different numbered routes, particularly two parallel or converging routes, signs may be provided on both routes if this is ultimately to the advantage of tourists (see Figure 9.34);
- (c) the facilities available at the tourist destination must be of a **standard which is acceptable** to a reasonable tourist;
- (d) when a number of tourist destinations can be reached in one direction, from a particular junction, an attempt shall be made to determine some **single collective name** which will adequately guide road users in the correct direction;
- (e) in extreme cases where many tourist destinations (and indeed local destinations as well) occur, consideration should be given to providing a suitable information facility (centre, bureau or layby) with enough local detailed information to simplify the local navigation process.
- 6 Tourist sign warrants for general use are provided in three levels as follows:
- (a) Level 1: general criteria relating to position and accessibility applicable to all groups of facility (see Subsection 9.5.11);
- (b) Level 2: criteria specific to each type of facility relating principally to hours of operation, distance from the approach road, and most important the quality rating of the facility (see Subsections 9.5.12 to 9.5.32);
- (c) Level 3: criteria specific to the design of the **TOURIST DIRECTION** sign to be provided with particular regard to (see Subsection 9.5.33):
- the use of a primary name;
 - supplementary tourist symbols;
 - a collective "area" symbol;
 - the distance to the facility;
 - a route number.
- 7 Level 1 and Level 3 warrants are applicable to all applications for **TOURIST DIRECTION** signs. Level 2 warrants, because they apply to individual facilities or facility groups, are listed separately in the group and type order given in Figure 9.22 and Table 9.2.
- 8 As has been noted previously, several generic, family or group symbols, and therefore warrants, are provided. Specific applicants for tourism signs may also not be aware of different symbol options available to them. More than one symbol, and therefore warrant, may, in fact, be permissible to represent their facility. LTO's and Regional Tourism Liaison Committee's should take pro-active action to:
- encourage the use of generic symbols as widely as possible (this applies particularly to the signing of High Density Tourism Areas);
 - otherwise guide applicants to choose **the single most appropriate symbol/warrant**, when options are available;
 - limit the use of supplementary symbols.

9 Subject to the principles given in paragraph 9.5.10.5 the tourist facility types listed in Table 9.2 may be signed in urban areas in accordance with the detailed requirements of the warrants given in subsequent subsections.

- 10 Special tourist related events, which occur on a one-off or irregular basis, may be signed using a temporary **SPECIAL EVENT** sign TGF17, commonly administered and erected by a service organisation such as the Automobile Association. Provision of sign TGF17 should adhere to the principle warrants laid down for similar full-time tourist facilities.

9.5.11 Level 1 Warrant Criteria:

- The following factors are taken into account for all tourist facilities, before continuing with the warrant investigation:
 - locational details:
 - (name of nearest town - rural only);
 - number of nearest numbered route (see paragraph 9.5.10.5(b));
 - is facility accessed directly or indirectly from this numbered route;
 - identification details of road from which access is obtained (when not a numbered route);
 - access warrants:
 - based on the locational details are tourism signs likely to be required or not;
 - even if facility is clearly visible from the road are tourism signs necessary to identify the point of access;
 - is the access road of an all-weather standard;
 - are internal roads of an adequate geometric standard to offer good mobility.

- The Level 2 warrants are detailed in the following subsections, in groups or individually, as appropriate. Where relevant, an illustration of the applicable tourism symbol is given. The subsections describe tourist attractions followed by emergency, vehicle, food, general and rest area services, and accommodation facilities.

9.5.12 Level 2 Warrant Criteria:

Tourist Attractions: All Groups

- The criteria listed in paragraph 9.5.12.2 are generic to all types of tourist attraction, identified in this Manual or in the future. If a specific criterion is appropriate to a facility type this will be noted in the relevant paragraph. Additional criteria are given for individual facility types in the subsequent subsections. All facility types are listed in these subsections even if they are unlikely to occur in urban areas, on the basis that almost any type of facility can occur in a peri-urban environment.
- The following generic warrants are applicable to all tourist attraction facilities:
 - shall be open to the public;
 - any on-site buildings shall comply with all statutory requirements of local and other authorities in terms of regulations such as Building Regulations SANS 10400:2011 or later, and if used for trading purposes shall legally be covered

by a current trading/operating licence;

- shall have a clean, attractive and well-kept appearance;
 - shall be in a good state of repair;
 - toilet facilities should be available (see paragraph 9.5.12.4):
 - for the public during open hours;
 - for both genders;
 - with adequate and suitable illumination;
 - with adequate natural and artificial ventilation;
 - subject to regular inspection for cleanliness and state of repair/maintenance;
 - shall be clearly signed;
 - shall have floor surfaces and levels that minimize any hazard;
 - shall have adequate safe parking for the highest anticipated visitor demand;
 - shall provide, or be mentioned in, an information brochure;
 - visitors shall be registered;
 - safety/medical response or contact information shall be provided;
 - shall provide an adequate number of rubbish/litter bins together with a regular rubbish removal service;
 - when a tourist attraction includes food and/or accommodation services these shall conform to the warrants for these services given in Subsections 9.5.28 and 9.5.32 respectively.
- 3 Wherever practical the following should also be provided:
- drinking water;
 - food services or picnic tables/braai facilities.
- 4 If a tourist attraction is in a completely natural state, with no built facilities, the requirement for toilets may be waived.
- 5 In the following subsections the first warrant criterion most commonly stated is a distance warrant. This distance warrant is a maximum distance and is always stated as being from the nearest numbered route. There is no reason why any urban authority may not adapt its own distance standards, but if it does these should be applied consistently. There is also no reason why a tourism symbol/sign cannot be warranted for use from a lesser road such as a tourism route or an un-numbered road. In particular, a lesser facility may be treated as a "sub-facility" off an already signed route to a more important facility i.e. an urban authority might decide to sign a lighthouse only from a road already signed to a destination such as a marine reserve, maritime museum or beach, any of which may have been signed from a nearest numbered route.
- 6 Certain types of tourist attraction, by virtue of their location and/or type of activity, may include hazards. It is recommended that this type of attraction should make the nature of such hazards known to entering members of the public, and that provision is made for the registration of entry within the facility by members of the public.

9.5.13 Level 2 Warrant Criteria: Tourist Attractions: Groups A1 and A2: National and Provincial Parks

- 1 Basic Requirements:
 - urban (peri-urban) - within 10 km of nearest numbered route;
 - reception shall be available 12 hours a day, 365 days per year, with provision to make prior reservations;
 - information shall be available from the reservations office;
 - shall exhibit indigenous flora and fauna.
- 2 Preferred requirements:
 - accommodation complying with appropriate warrants (see Subsection 9.5.32);
 - facilities such as restaurants, picnic tables, braai facilities and boat spillways, each complying with appropriate warrants.

9.5.14 Level 2 Warrant Criteria: Tourist Attractions: Group A3: Resort Attractions

- 1 Basic Requirements:
 - urban (peri-urban) - within 5 km of nearest numbered route;
 - accommodation shall be provided which complies with appropriate warrants (see Subsection 9.5.32);
 - reception shall be available 12 hours a day, 365 days per year, with provision to make prior reservations;
 - information to be available from the reservations office;
 - if water and/or shoreline activities are included these shall be safely and effectively co-ordinated and certified by the Departments of Environmental Affairs (DEA), Water Affairs(DWA), Tourism (DT) and/or Agriculture, Forestry & Fisheries (DAF&F), as appropriate or their appointed agents;
 - day visitors shall also be catered for;
 - when appropriate changing room facilities shall be provided;
 - food services in the form of restaurants, refreshments, take-away, picnic tables or braai facilities shall be available;
 - if sporting facilities are an integral part of the resort these shall be available to day visitors and residents, and shall comply with appropriate warrants (see Subsection 9.5.16 : Sports Attractions).
- 2 Other factors:
 - resorts with exclusive membership shall not fulfil the warrant requirements;
 - when appropriate, interpretive material may be provided within the resort;
 - if sporting facilities are provided, indoor and outdoor sports should preferably be catered for and should be available to all visitors.

9.5.15 Level 2 Warrant Criteria: Tourist Attractions: Group A4: Scenic Attractions

1 Scenic Route (and generic Scenic Attractions):



GFS A4

This symbol may be used either to indicate a Scenic Route (which may, or may not, be numbered as a Tourist Route), or to indicate a High Density Tourism Area with a "scenic" theme, subject to compliance with the applicable warrants for a tourist route or HDTA, or any of the individual scenic attractions within Group A4. In the latter two cases the applicable warrants will be those for a HDTA or those listed below.

Basic requirements for an urban Scenic Route are:

- shall involve primarily a natural and/or open and undeveloped environment with panoramic views;
- frequent, and adequately signposted and developed stopping/parking areas at specific View Points (see GFS A4-8), or other scenic attractions, shall be provided;
- may include sections in a built-up urban environment which offer wide vistas of the urban area, particularly including views of buildings of architectural and/or historical significance, but which are not **primarily** arterial routes.

2 Nature Reserve:



GFS A4-1

Basic requirements:

- urban and peri-urban - within 10 km of the nearest numbered route;
- shall be subject to environmental management as required by the DEA, DWA, DT and/or DAF&F, as appropriate, or their appointed agents;
- the site shall be open 365 days a year;
- there shall be adequate sign posting;
- drinking water shall be provided;
- a public telephone shall be provided;
- regular outdoor seating shall be provided;
- access to, and touring of the site, shall be disabled/elderly friendly;
- archaeological sites shall be identified, and protected by vehicular and pedestrian barriers;
- parking shall not be permitted within +/- 100 m of an archaeological site;

- camping shall not be permitted within +/- 1 km of an archaeological site.

Preferred requirements:

- if practical, a reception area with adequate information should be provided;
- interpretive information should be provided, when appropriate, within the site;
- the availability of picnic sites, wildlife viewing hides, viewpoints and hiking trails should be considered;
- the availability of refreshments should be considered.

Other factors:

- if, for whatever reason, the nature reserve is only available by appointment, or is kept locked, a guide should be available and clear instructions given for the collection and return of the key.

3 National Heritage:



GFS A4-2(RSA)

Basic requirements:

- urban and peri-urban - within 10 km of the nearest numbered route;
- the site shall be a registered South African National Heritage Site.

Preferred requirements:

- permanent indoor or outdoor exhibitions;
- permanent information/notice board.

4 Botanical Gardens:



GFS A4-3

Basic requirements:

- urban and peri-urban - within 5 km of the nearest numbered route;
- the gardens shall be registered with the Natural Botanical Gardens Society;
- the gardens shall be open 365 days a year;
- regular outdoor seating shall be provided;
- access to, and touring of, the gardens shall be disabled/elderly friendly;
- interpretive information shall be provided within the gardens.

5 Gardens (Flower):



GFS A4-4

Basic requirements:

- parking shall not be permitted within +/- 100 m of an archaeological site;
- urban and peri-urban - within 2 km of the nearest numbered route;
- the gardens shall be open 365 days a year;
- regular outdoor seating shall be provided;
- access to, and touring of, the gardens shall be disabled/elderly friendly;
- interpretive information shall be provided within the gardens.

6 Waterfall:



GFS A4-5

Basic requirements:

- urban and peri-urban - within 10 km of the nearest numbered route;
- shall be accessible by the public 365 days a year;
- visiting public shall be provided with effective protection measures if hazards exist.

7 Lake or Dam (no water-sport)



GFS A4-6

Basic requirements:

- urban and peri-urban - within 10 km of the nearest numbered route;
- shall be subject to environmental management as required by the DEA, DWA, DT and/or DAF&F, as appropriate, or their appointed agents;
- the site shall be accessible by the public 365 days a year;
- a public telephone shall be provided;
- access to, and touring of, the gardens shall be disabled/elderly friendly;
- regular outdoor seating shall be provided;
- there shall be adequate signposting.

Preferred requirements:

- interpretive information should be provided, when appropriate, within the site in addition to conventional visitor information;
- the availability of picnic sites, wildlife viewing hides, viewpoints and hiking trails should be considered;
- food services in the form of restaurants, refreshments, take-away, picnic tables, or braai facilities may be provided.

Other factors:

- if, for whatever reason, the lake or dam is only available by appointment, or is kept locked, a guide should be available and clear instructions given for the collection and return of the key.

8 Caves:



GFS A4-7

Basic requirements:

- urban and peri-urban - within 10 km of the nearest numbered route;
- shall be subject to environmental **and safety** management certification by the DEA, DWA, DT and/or DAF&F, as appropriate, or their appointed agents;
- any areas **not open** to the public shall be clearly identified;
- archaeological sites shall be identified and protected;
- the site shall be open for a minimum of 6 hours a day, 365 days a year;
- subject to the available open time a shaded waiting area shall be provided for the time period(s) when the caves are not open;
- basic and interpretative information shall be available on site.

Preferred requirements:

- drinking water should be available.

9 View Point



GFS A4-8

Basic requirements:

- urban and peri-urban - within 5 km of the nearest numbered route;
- should provide panoramic views of sea, mountain or general landscapes and/or an aesthetic urban scene;
- the site shall be accessible 365 days a year;
- the site shall be adequately provided with protective measures against any hazards;

- regular outdoor seating shall be provided.

Preferred Requirements:

- drinking water should be available;
- an information board detailing specific points of interest may be provided (this board may form part of an integrated urban tourist information system).

10 Natural Forest:



GFS A4-9

Basic requirements:

- urban and peri-urban - within 10 km of the nearest numbered route;
- shall be subject to environmental management as part of a primary conservation area as required by the DEA, DWA, DT and/or DAF&F, as appropriate, or their appointed agents;
- regular outdoor seating shall be provided;
- there shall be adequate sign posting;
- any areas **not open** to the public shall be clearly identified;
- visiting public shall be provided with effective protection measures if hazards exist.

Preferred requirements:

- drinking water should be available;
- if practical, a reception area with adequate information should be provided;
- interpretive information should be provided;
- at least some sections of the forest should be disabled/elderly friendly, if practical;
- the availability of picnic sites, wild life viewing areas, view-points and hiking trails should be considered.

11 State Forest:



GFS A4-10

The basic and preferred requirements should be as stated for Natural Forest (GFS A4-9) except that the environmental management shall be under the jurisdiction of the DEA, DWA, DT and/or DAF&F, as appropriate, or their appointed agents.

12 Mountain/Berg:



GFS A4-11

Basic requirements:

- urban and peri-urban - within 25 km of the nearest numbered route;
- shall include drives, walks, view-points and resting areas appropriate to the general mountain/berg environment or the specific nature of any unique features of the area;
- the area shall be adequately signposted.

Preferred requirements:

- subject to the size of the area adequate provision of drinking water, picnic sites/braai areas etc. should be made;
- strategically sited public telephones should be available.

9.5.16 Level 2 Warrant Criteria: Tourist Attractions: Group A5: Sports Attractions

1 Generic Sports Attractions:

Symbol design pending

This symbol may be used as a collective or generic symbol for any major attraction which caters for a wide range of sports. A road authority may alternatively or additionally adopt the symbol as a generic symbol for all sports attractions within Group A5, subject to the individual warrants given below.

Basic requirements for a major sports attraction complex are:

- urban and peri urban - within 2 km of the nearest numbered route;
- shall cater for several sports in one stadium, arena or other environment, or several sports in several integrated stadiums and/or arenas, at national and international level;
- shall cater for a minimum of 25 000 spectators with full compliance with all generic criteria identified in Subsection 9.5.12 in terms of any applicable local authority regulations or by-laws (this spectator requirement applies for the recognised metropolitan authority areas, a commensurate spectator requirement may be adopted for smaller urban authorities);
- shall provide adequate parking consistent with the permitted maximum number of spectators (this parking may be provided at remote locations subject to the local authority setting up an exclusive public transport service on the days of events, in which case additional signs shall be provided directing spectators to the remote parking areas).

2 **Motor Racing Track:**



GFS A5-1

Basic requirements:

- urban and peri-urban :
 - the nearest numbered route for tracks running national and international events;
 - tertiary arterial or collector-distributor road (Class AC@) for smaller venues;
- shall cater for either of the following to qualify for a sign from the nearest numbered route :
 - at least one nationally graded event a year; or
 - programme of local events over a season lasting several weeks;
- shall provide adequate points of access and egress to cater for the permitted spectator levels;
- shall provide adequate, secure on-site parking;
- if international events are held, a specific traffic management plan shall be available.

3 **Golf Course** (see also symbol GFS A3-1):



GFS A5-2

Basic requirements:

- urban and peri-urban:
 - within 2 km of the nearest numbered route, if the course is graded by the national golf organisation to hold national events;
 - within 1 km of a tertiary arterial or collector-distributor road (Class AC@) for smaller venues;
- shall make adequate provision to comply with the generic criteria identified in Subsection 9.5.12 in terms of any applicable local authority regulations or by-laws when spectators are present at an event.

4 **(Horse) Race Course:**



GFS A5-3

Basic requirements:

- urban and peri-urban:
 - within 2 km of the nearest numbered route, if the course is

graded by the national horse racing organisation to hold national events;

- within 1 km of a tertiary arterial or collector-distributor road (Class AC@) for smaller venues;
- shall provide adequate, secure on-site parking and/or exclusive public transport.

5 **Equestrian Events** (other than exclusive horse racing venues see GFS A5-3):



GFS A5-4

Basic requirements:

- urban and peri-urban - within 2 km of the nearest numbered route;
- shall hold equestrian events on at least a monthly basis (otherwise the venue should be considered some other more generic classification such as Ashow-ground@);
- shall make adequate provision to comply with the generic criteria identified in Subsection 9.5.12 in terms of any applicable local authority regulations or by-laws when spectators are present at an event.
- shall provide adequate, secure on-site parking.

6 **Fishing**



GFS A5-5

Basic requirements:

- urban and peri-urban - within 5 km of the nearest numbered route;
- shall be registered as a venue with a national or provincial angling organisation and shall be monitored by such organisation or by a registered angling club affiliated to the organisation.

Preferred requirements:

- drinking water should be available close by;
- picnic and/or braai facilities;
- adjacent accommodation (subject to appropriate warrants - see Subsection 9.5.32);
- shall be open to the public 365 days a year (subject to environmental constraints or review for specifically adverse circumstances);
- information on costs, rules and regulations shall be clearly displayed at the site.

7 **Cricket Field:**

GFS A5-6

Basic requirements:

- urban and peri-urban:
 - within 2 km of the nearest numbered route for cricket fields catering for national or international events;
 - within 1 km of a tertiary arterial or collector-distributor road (Class AC@) for smaller venues;
- shall provide adequate parking consistent with the permitted maximum number of spectators (this parking may be provided at remote locations subject to the local authority setting up an exclusive public transport service on the days of events, in which case additional signs shall be provided directing spectators to the remote parking areas);
- if international events are held, a specific traffic management plan shall be available;
- shall make adequate provision to comply with the generic criteria identified in Subsection 9.5.12 in terms of any applicable local authority regulations or by-laws when spectators are present at an event.

8 **Swimming Pool:**

GFS A5-7

Basic requirements:

- urban and peri-urban:
 - within 2 km of the nearest numbered route for swimming pools catering for national or international events;
 - within 1 km of a tertiary arterial or collector-distributor road (Class AC@) for smaller venues;
- shall provide adequate parking consistent with the permitted maximum number of spectators;
- shall make adequate provision to comply with the generic criteria identified in Subsection 9.5.12 in terms of any applicable local authority regulations or by-laws when spectators are present at an event.

9 **Sports Stadiums** (see also generic symbol GFS A5):

GFS A5-8

Basic requirements:

- urban and peri urban - within 2 km of the nearest numbered route;

- shall cater for a minimum of 25 000 spectators with full compliance with all generic criteria identified in Subsection 9.5.12 in terms of any applicable local authority regulations or by-laws (this spectator requirement applies for the recognised metropolitan authority areas, a commensurate spectator requirement may be adopted for smaller urban authorities);
- shall provide adequate parking consistent with the permitted maximum number of spectators (this parking may be provided at remote locations subject to the local authority setting up an exclusive public transport service on the days of events, in which case additional signs shall be provided directing spectators to the remote parking areas).

9.5.17 Level 2 Warrant Criteria: Tourist Attractions: Group A6: Wildlife Attractions

1 **Generic Wildlife Attractions:**

GFS A6

This symbol may be used as a collective or generic symbol for a Wildlife Route (which may, or may not, be numbered as a Tourist Route) or High Density Tourism Area with a Wildlife theme, subject to compliance with the applicable warrants for a tourist route or HDTA, or any of the individual wildlife attractions within Group A6, or those listed below for individual facilities.

2 **Conservancy Area:**

GFS A6-1

Basic requirements:

- urban and peri-urban - within 5 km of the nearest numbered route;
- environmental management principles, including responsible and sustained tourism development principles shall be fundamental to all activities pertaining to the use of the resources;
- the area shall include at least five tourist attractions that are co-ordinating their efforts in the interests of conserving natural assets of the area and which promote the principles of conservancy;
- a brochure/map identifying the area and the facilities within it shall be available;
- the individual facilities within the area, shall, if they include other aspects of tourist interest, conform to the warrants appropriate to these other aspects of interest;
- the individual facilities shall make adequate provision to comply with the generic criteria identified in Subsection 9.5.12.

3 **Game Reserve** (see also generic symbol GFS A6) :



GFS A6-2

Basic requirements:

- urban and peri-urban - within 5 km of the nearest numbered route;
- shall have approval to operate from a recognised animal protection group or the Zoological Society of Southern Africa, and shall be regularly inspected by such a group/society;
- environmental management principles, including responsible and sustained tourism development principles shall be fundamental to all activities pertaining to the use of the resources;
- shall be open to day visitors for at least 6 hours per day, during which a reception facility shall be available, for 365 days a year;
- shall have a clearly documented communication and emergency procedure to be followed by officials in the event of an incident;
- comprehensive visitor information, interpretive material, warnings against specific hazards, and procedures to be followed by the public in the event of an emergency shall be clearly displayed;
- shall provide a daily programme of awareness/ educational presentations.

Preferred requirements:

- permanent hides or other viewing areas in secure situations to permit visitors to leave their vehicles;
- any food service which conform to the warrants given in Subsection 9.5.28;
- secure areas in which visitors may leave their vehicles to picnic or braai - such areas shall be provided with drinking water;
- accommodation may be provided which conforms with to the warrants given in Subsection 9.5.32 - such attractions may alternatively apply for signing as a resort - see Subsection 9.5.14.

4 **Bird Park/Sanctuary:**



GFS A6-3

Basic requirements:

- urban and peri-urban - within 5 km of the nearest numbered route;
- shall have approval to operate from a recognised animal protection group or the Zoological Society of Southern Africa, and shall be regularly inspected by such a group/society;

- environmental management principles, including responsible and sustained tourism development principles shall be fundamental to all activities pertaining to the use of the resources;
- shall be open to day visitors for at least 6 hours per day, during which a reception facility shall be available, for 365 days a year;
- shall have a clearly documented communication and emergency procedure to be followed by officials in the event of an incident;
- comprehensive visitor information, interpretive material, warnings against specific hazards, and procedures to be followed by the public in the event of an emergency shall be clearly displayed;
- drinking water shall be available;
- provision shall be made specifically to cater for the disabled and elderly;
- shall provide a daily programme of awareness/ educational presentations.

Preferred requirements:

- any food service which conform to the warrants given in Subsection 9.5.28;
- areas suitable for a picnic or braai with drinking water.

5 **Zoo** (see also generic symbol GFS A6):



GFS A6-4

Basic requirements:

- urban and peri-urban - within 5 km of the nearest numbered route;
- shall have approval to operate from a recognised animal protection group or the Zoological Society of Southern Africa, and shall be regularly inspected by such a group/society;
- environmental management principles, including responsible and sustained tourism development principles shall be fundamental to all activities pertaining to the use of the resources;
- shall be open to day visitors for at least 6 hours per day, during which a reception facility shall be available, for 365 days a year;
- shall have a clearly documented communication and emergency procedure to be followed by officials in the event of an incident;
- comprehensive visitor information, interpretive material, warnings against specific hazards, and procedures to be followed by the public in the event of an emergency shall be clearly displayed;
- drinking water shall be available;

- provision shall be made specifically to cater for the disabled and elderly;
- shall provide a daily programme of awareness/ educational presentations.

Preferred requirements:

- any food service which conform to the warrants given in Subsection 9.5.28.

6 Snake Park:



GFS A6-5

Basic requirements:

- urban and peri-urban - within 5 km of the nearest numbered route;
- shall have approval to operate from a recognised animal protection group or the Zoological Society of Southern Africa, and shall be regularly inspected by such a group/society;
- environmental management principles, including responsible and sustained tourism development principles shall be fundamental to all activities pertaining to the use of the resources;
- shall be open to day visitors for at least 6 hours per day, during which a reception facility shall be available, for 365 days a year;
- shall have a clearly documented communication and emergency procedure to be followed by officials in the event of an incident;
- specific safety precautions shall include:
 - proper access control;
 - an impenetrable perimeter wall;
 - warnings to visitors of any specific risks or hazards;
- comprehensive visitor information, interpretive material, and procedures to be followed by the public in the event of an emergency shall be clearly displayed;
- drinking water shall be available;
- provision shall be made specifically to cater for the disabled and elderly;
- shall have on display a minimum of 20 different types of snake, of which at least half shall be indigenous types of snake;

- snakes shall be kept in secure, locked areas with no possibility of public contact;
- shall provide a daily programme of awareness/ educational presentations which shall be from within secure enclosures if snake handling is involved.

Preferred requirements:

- any food service which conform to the warrants given in Subsection 9.5.28.

7 Crocodile Park:



GFS A6-6

Basic requirements:

- urban and peri-urban - within 5 km of the nearest numbered route;
- shall have approval to operate from a recognised animal protection group or the Zoological Society of Southern Africa, and shall be regularly inspected by such a group/society;
- environmental management principles, including responsible and sustained tourism development principles shall be fundamental to all activities pertaining to the use of the resources;
- shall be open to day visitors for at least 6 hours per day, during which a reception facility shall be available, for 365 days a year;
- shall have a clearly documented communication and emergency procedure to be followed by officials in the event of an incident;
- comprehensive visitor information, interpretive material, warnings against specific hazards, and procedures to be followed by the public in the event of an emergency shall be clearly displayed;
- the main activities shall be crocodile related - other fauna/flora may also be featured;
- drinking water shall be available;
- provision shall be made specifically to cater for the disabled and elderly.
- shall provide a daily programme of awareness/ educational presentations.

Preferred requirements:

- any food service which conform to the warrants given in Subsection 9.5.28.

8 **Rhino Park** (see also generic symbol GFS A6):

GFS A6-7

Basic requirements:

- urban and peri-urban - within 5 km of the nearest numbered route;
- shall have approval to operate from a recognised animal protection group or the Zoological Society of Southern Africa, and shall be regularly inspected by such a group/society;
- environmental management principles, including responsible and sustained tourism development principles shall be fundamental to all activities pertaining to the use of the resources;
- shall be open to day visitors for at least 6 hours per day, during which a reception facility shall be available, for 365 days a year;
- shall have a clearly documented communication and emergency procedure to be followed by officials in the event of an incident;
- comprehensive visitor information, interpretive material, warnings against specific hazards, and procedures to be followed by the public in the event of an emergency shall be clearly displayed;
- the main activities shall be rhino related and a minimum of 10 rhino shall be on view to the public, within the park, at any time - other fauna/flora may also be featured;
- drinking water shall be available;
- provision shall be made specifically to cater for the disabled and elderly;
- shall provide a daily programme of awareness/ educational presentations.

Preferred requirements:

- guided tours may be provided;
- permanent hides or other viewing areas may be provided in secure situations to permit visitors to leave their vehicles;
- any food service which conform to the warrants given in Subsection 9.5.28;
- secure areas in which visitors may leave their vehicles to picnic or braai - such areas shall be provided with drinking water.

9 **Lion Park** (see also generic symbol GFS A6):

GFS A6-8

Basic requirements:

- urban and peri-urban - within 5 km of the nearest numbered route;
- shall have approval to operate from a recognised animal protection group or the Zoological Society of Southern Africa, and shall be regularly inspected by such a group/society;
- environmental management principles, including responsible and sustained tourism development principles shall be fundamental to all activities pertaining to the use of the resources;
- shall be open to day visitors for at least 6 hours per day, during which a reception facility shall be available, for 365 days a year;
- shall have a clearly documented communication and emergency procedure to be followed by officials in the event of an incident;
- comprehensive visitor information, interpretive material, warnings against specific hazards, and procedures to be followed by the public in the event of an emergency shall be clearly displayed;
- the main activities shall be lion related and a minimum of 10 lions shall be on view to the public, within the park, at any time - other fauna/flora may also be featured;
- drinking water shall be available;
- provision shall be made specifically to cater for the disabled and elderly;
- shall provide a daily programme of awareness/ educational presentations.

Preferred requirements:

- guided tours may be provided;
- permanent hides or other viewing areas may be provided in secure situations to permit visitors to leave their vehicles;
- visitors may be invited to watch the feeding of the lions;
- any food service which conform to the warrants given in Subsection 9.5.28.

9.5.18 Level 2 Warrant Criteria: Tourist Attractions: Group A7: Historic Attractions

1 Generic Historic Attractions:



GFS A7

This symbol may be used as a collective or generic symbol for an Historic Route (which may, or may not be numbered as a Tourist Route) or High Density Tourist Area with an 'historic' theme, subject to compliance with the applicable warrants for a tourist route of HDTA, or any of the individual historic attractions within Group A7. In the latter two cases the applicable warrants will be those for a HDTA or those listed below.

2 National Monument:



GFS A7-1(RSA)

Basic requirements:

- urban and peri-urban - within 2 km of the nearest numbered route;
- shall be a National Monument listed by the National Monuments Council of South Africa and identified by a NMCSA plaque;
- shall be available for external viewing 365 days a year;
- shall be open to full public visits on a regular weekly basis throughout the year (including effective access to the insides of buildings/sites i.e. certain areas such as workshops, archives etc. may not be open to the general public);
- shall otherwise comply, as appropriate to the specific National Monument, with the warrant requirements for museums given below.

3 Museum (see also generic symbol GFS A7 and Maritime Museum GFS A8-2):



GFS A7-2

NOTE:

Museums may vary widely in nature and may be located at or in a National Monument (see GFS A7-1). The details given below are subdivided into 'General Museums' and 'Site Museums'. The former are generally considered to be primarily contained in buildings, whereas the latter may be open field

sites commonly of archaeological interest.

General Museums - basic requirements:

- urban - within 1 km of the nearest numbered route;
- peri-urban - within 2 km of the nearest numbered route;
- the premises shall be open to the public at least 6 days per week, during which a reception facility shall be available, all year round;
- any rooms/areas not open to the public shall be clearly identified;
- comprehensive visitor information and interpretive material shall be available;
- a public telephone shall be available;
- drinking water shall be available;
- indoor and outdoor seating shall be provided;
- the premises shall be disabled/elderly friendly.

Site Museums - basic requirements:

- urban and peri-urban - within 5 km of the nearest numbered route;
- environmental management principles shall be fundamental to all activities pertaining to the use of the site;
- archaeological sites shall be identified, and protected by vehicular and pedestrian barriers;
- parking shall not be permitted within approximately 100 m of an archaeological site;
- camping shall not be permitted within approximately 1 km of an archaeological site;
- the site shall be open to the public 365 days a year;
- a public telephone shall be available;
- drinking water shall be available;
- indoor and outdoor seating shall be provided;
- access to, and touring of the site, shall be disabled/elderly friendly;
- visiting public shall be provided with adequate protective measures if hazards exist;
- comprehensive visitor information and interpretive material shall be available - this shall include adequate pedestrian guidance signing.

Preferred requirements:

- refreshments and/or a picnic site/braai area should be available;
- when appropriate view points and/or hiking trails should be considered.

Other factors:

- if, for whatever reason, the museum or site museum is only available by appointment, or is kept locked, a guide should be available and clear instructions given for the collection and return of the key.

4 **Historic Mine** (see also generic symbol GFS A7):



GFS A7-3

Basic requirements:

- urban and peri-urban - within 2 km of the nearest numbered route;
- shall be open to visitors 365 days a year during which a reception facility shall be available;
- comprehensive visitor information and interpretive material, including permanent exhibits, shall be provided;
- a public telephone shall be available;
- drinking water shall be available;
- indoor and outdoor seating shall be provided;
- access to, and touring of the site, shall be disabled/elderly friendly.

Preferred/optional requirements:

- any food services which comply with the warrants given in Subsection 9.5.28;
- the historic mine environment may include, or be part of an historic theme park.

5 **Historic Railway** (see also generic symbol GFS A7):



GFS A7-4

Basic requirements:

- urban and peri-urban - a station or viewing point shall be within 2 km of the nearest numbered route;
- historic trains shall run on at least 6 days a week all year round (a lesser frequency of operation may be assessed in terms of possible inclusion in a high density tourism area);
- comprehensive visitor information and interpretive material shall be available;
- a public telephone shall be available at all stations;
- drinking water shall be available at regular intervals;
- special provisions shall be made to accommodate the disabled and elderly.

Preferred requirements:

- refreshments and/or a picnic/braai area should be available at stations;
- photo opportunity viewing points may be provided.

6 **Historic Battlefield** (see also generic symbol GFS A7, National Monument symbol GFS A7-1 and Museum symbol GFS A7-2):



GFS A7-5

Basic requirements:

- urban and peri-urban - the site, or start, and/or other sections, of a tourist route serving several sites, shall be within 2 km of the nearest numbered route;
- the site shall be open to the public 365 days a year;
- comprehensive visitor information and interpretive material shall be available;
- access to, and touring of the site, shall be disabled/elderly friendly.

Preferred requirements (several of these requirements would normally be basic requirements, but, in recognition of the open field nature of many historic battlefield sites they are listed as preferred):

- a public telephone should preferably be available;
- drinking water should preferably be available;
- seating should be provided as appropriate;
- adequate pedestrian guidance signing should be provided.

7 **Historic Cemetery** (see also generic symbol GFS A7 and National Monument symbol GFS A7-1):



GFS A7-6

Basic requirements:

- urban and peri-urban - the site, or start, and/or other sections, of a tourist route serving several sites, shall be within 2 km of the nearest numbered route;
- the site shall be open to the public 365 days a year;
- comprehensive visitor information and interpretive material shall be available;
- access to, and touring of the site, shall be disabled/elderly friendly.

Preferred requirements (several of these requirements would normally be basic requirements, but, in recognition of the open field nature of many historic cemetery sites they are listed as preferred):

- a public telephone should preferably be available;
- drinking water should preferably be available;
- seating should be provided as appropriate;
- adequate pedestrian guidance signing should be provided

8 **Geological Site** (see also generic symbol GFS A7):

GFS A7-7

Basic requirements:

- urban and peri-urban - within 2 km of the nearest numbered route;
- environmental management principles shall be fundamental to all activities pertaining to the use of the site;
- the site shall be open to the public 365 days a year;
- if the site is of archaeological importance, the relevant parts of the site shall be identified and protected by vehicular and pedestrian barriers - parking shall not be permitted within approximately 100 m of an archaeological area nor shall camping be permitted within approximately 1 km of such an area;
- comprehensive visitor information and interpretive material shall be available.

Preferred requirements (several of these requirements would normally be basic requirements, but, in recognition of the open field nature of many historic cemetery sites they are listed as preferred):

- a public telephone should preferably be available;
- drinking water should preferably be available;
- seating should be provided as appropriate;
- adequate pedestrian guidance signing should be provided.

9.5.19 Level 2 Warrant Criteria: Tourist Attractions: Group A8: Coastal Attractions

1 **Generic Coastal Attractions:**

GFS A8

This symbol may be used either to indicate a (Scenic) Coastal Route (which may or may not, be numbered as a Tourist Route), or to indicate a High Density Tourism Area with a coastal theme, subject to compliance with the applicable warrants for a tourist route or HDTA, or any of the individual coastal attractions within Group A4. In the latter two cases the applicable warrants will be those for a HDTA or those listed below.

Basic requirements for a Coastal Route are:

- shall involve primarily a natural and/or open and undeveloped environment with panoramic sea views adjoining or within an urban or peri-urban area;
- frequent and adequately sign posted developed stopping/parking areas at specific viewpoints (see GFS A4-8),

or other scenic coastal attractions, shall be provided;

- may include sections in a built-up urban environment which offer wide coastal vistas.

2 **Marine Reserve** (see also generic symbol GFS A8):

GFS A8-1

Basic requirements:

- urban and peri-urban - within 5 km of the nearest numbered route;
- shall be registered with a national or provincial nature conservation organisation;
- shall be accessible to the public at least 12 hours a day for 365 days a year;
- environmental management principles shall be fundamental to all activities pertaining to the use of the site;
- comprehensive visitor information and interpretive material shall be available - this information shall include details of restrictions on angling, spear fishing and collection of crustaceans.

Preferred requirements:

- should exhibit indigenous flora/fauna;
- drinking water should be available;
- the reserve may be associated with accommodation provided this complies with the relevant warrants given in Subsection 9.5.32.

3 **Maritime Museum** (see also generic symbol GFS A8 and Museum (Site Museum) symbol GFS A7-2):

GFS A8-2

Basic requirements:

- urban and peri-urban - within 5 km of the nearest numbered route;
- environmental management principles shall be fundamental to all activities pertaining to the use of the site;
- the site shall be open to the public 365 days a year;
- a public telephone (or telephones) shall be available;
- drinking water shall be available;
- indoor/outdoor seating shall be provided as appropriate;
- comprehensive visitor information and interpretive material shall be available;
- adequate pedestrian guidance signing shall be provided

Preferred requirements:

- refreshments and/or a picnic/braai area should be available;
- when appropriate, viewpoints and/or hiking trails should be considered.

4 **Aquarium** (see also generic symbol GFS A8):



GFS A8-3

Basic requirements:

- urban and peri-urban - within 1 km of the nearest numbered route;
- shall have approval to operate from a recognised animal protection group or the Zoological Society of Southern Africa, and shall be regularly inspected by such a group/society;
- shall be open to the public 365 days a year;
- registration/reception shall be available;
- comprehensive visitor information and interpretive material shall be available.

Preferred requirements:

- displays should be limited to indigenous marine fish/crustaceans;
- adequate seating should be provided;
- refreshments should be available.

5 **Whales** (see also generic symbol GFS A8):



GFS A8-4

Basic requirements:

- urban and peri-urban - the viewing site, or start, and/or other sections, of a tourist route serving several such sites, shall be within 2 km of the nearest numbered route;
- shall be accessible to the public 365 days a year (although viewing is expected to be seasonal);
- adequately sized view sites shall be provided at environmentally acceptable points on the coast line for the purpose of viewing whales (see also GFS A8-5);
- each view site shall be provided with adequate parking;
- each view site shall be provided with seating;
- interpretive information and brochures on whales and their environment shall be displayed/available.

Preferred requirements:

- drinking water should be available.

6 **Dolphins** (see also generic symbol GFS A8):



GFS A8-5

Basic requirements:

- urban and peri-urban - the viewing site, or start, and/or other sections, of a tourist route serving several such sites, shall be within 2 km of the nearest numbered route;
- shall be accessible to the public 365 days a year;
- adequately sized view sites shall be provided at environmentally acceptable points on the coast line for the purpose of viewing dolphins (see also GFS A8-5);
- each view site shall be provided with adequate parking;
- each view site shall be provided with seating;
- interpretive information and brochures on dolphins and their environment shall be displayed/available.

Preferred requirements:

- drinking water should be available.

7 **Lighthouse** (see also generic symbol GFS A8):



GFS A8-6

Basic requirements:

- urban - within 1 km of the nearest numbered route;
- peri-urban - within 2 km of the nearest numbered route;
- shall be accessible to the public 365 days a year;
- shall be provided with seating.

Preferred requirements:

- visitor information and interpretive material should be available;
- drinking water should be available.

8 **Dockyard** (see also generic symbol GFS A8):

GFS A8-7

Basic requirements:

- urban - within 1 km of the nearest numbered route;
- peri-urban - within 2 km of the nearest numbered route;
- shall be accessible to the public 365 days a year;
- shall include features open to the public for viewing in addition to normal dockyard activities such as :
 - historic features;
 - working features with safe viewing areas and comprehensive visitor information and interpretive material;
 - ship/boat building illustrating various skills and crafts;
- shall provide effective internal signing for vehicles and pedestrians as appropriate;
- shall provide adequate rest and refreshment opportunities;
- shall clearly indicate hazardous areas and areas to which the visiting public are not permitted entry.

Preferred requirements:

- general visitor information and interpretive material should be provided.

9 **Boat Launch** (see also generic symbol GFS A8):

GFS A8-8

Basic requirements:

- urban and peri-urban - within 2 km of the nearest numbered route;
- shall be accessible to the public 365 days a year;
- the immediate area of the boat launch shall be surfaced with a hard wearing and weather resistant surface and shall be sufficiently large to facilitate easy manoeuvring of vehicles and trailers.

10 **(Coastal) Fishing** (see also generic symbol GFS A8):

GFS A8-9

Basic requirements:

- urban and peri-urban - within 2 km of the nearest numbered route;
- shall be registered as a coastal venue with a national or provincial angling organisation and shall be monitored by such organisation or by a registered angling club affiliated to the organisation.

Preferred requirements:

- drinking water should be available close by;
- picnic and/or braai facilities;
- adjacent accommodation (subject to appropriate warrants - see Subsection 9.5.32);
- shall be open to the public 365 days a year (subject to environmental constraints or review for specifically adverse circumstances);
- information on costs, rules and regulations shall be clearly displayed at the site.

11 **Crayfish** (see also generic symbol GFS A8) :

GFS A8-10

Basic requirements:

- urban and peri-urban - the site, or start, and/or other sections, of a tourist route serving several such sites, shall be within 2 km of the nearest numbered route;
- shall be accessible to the public 365 days a year (although facility is expected to be seasonal);
- adequately sized sites shall be provided at environmentally acceptable points on the coast line for the purpose of purchasing crayfish;
- each site shall be provided with adequate parking;
- each site shall be provided with seating;
- interpretive information and brochures on crayfish and their environment shall be displayed/available.

Preferred requirements:

- drinking water should be available.

12 Oceanarium (see also generic symbol GFS A8):



GFS A8-11

Basic requirements:

- urban and peri-urban - within 1 km of the nearest numbered route;
- shall have approval to operate from a recognised animal protection group or the Zoological Society of Southern Africa, and shall be regularly inspected by such a group/society;
- shall be open to the public 365 days a year;
- registration/reception shall be available;
- comprehensive visitor information and interpretive material shall be available.

Preferred requirements:

- displays, which may include aquarium elements, should specifically feature indigenous marine fauna, fish and crustaceans;
- adequate seating should be provided;
- refreshments should be available.

13 Beach (see also generic symbol GFS A8):



GFS A8-12

Basic requirements:

- urban and peri-urban - within 2 km of the nearest numbered route;
- shall be available to the public 365 days a year (and shall not be directly linked to a resort (see Group A3), or to accommodation);
- shall be sign posted to indicate whether swimming is safe or not on a real-time basis;
- any other regulations pertaining to the use of the beach shall be clearly visible to all;
- the procedures to be followed in the event of an emergency shall be clearly indicated;
- the beach shall be cleaned frequently.

Preferred requirements:

- a public telephone should preferably be available;
- drinking water should preferably be available;
- if swimming is permitted, fresh water showers should be provided.

9.5.20 Level 2 Warrant Criteria:
Tourist Attractions: Group A9:
Arts & Crafts

1 Generic Arts & Crafts Attractions:



GFS A9

This symbol may be used either to indicate an Arts & Crafts Route (which may, or may not be numbered as a Tourist Route), or to indicate a High Density Tourist Area with an Arts & Crafts theme, subject to compliance with the applicable warrants for a tourist route or HDTA, or any of the individual attractions within Group A9. In the latter two cases the applicable warrants will be those for a HDTA or those listed below.

Basic requirements for an Arts & Crafts Route are:

- shall involve, primarily (but not exclusively), tourist attractions within close proximity or with direct access from the route in question, which demonstrate a range of arts & crafts of both or either indigenous or non-indigenous origins;
- whilst the individual attractions may offer products for sale they should promote awareness of the historical background to the skills involved and show the skills in use in the creation of articles of artistic or craft merit;

Other aspects:

- it is a common feature of Arts & Crafts attractions that they are not open to the public on a 365 days a year basis - such facilities will only warrant the provision of part-time tourism sign type GF17 when they are within a co-ordinated high density tourism area - the density of facilities within such an area will, if warrants are fulfilled, warrant the use of full-time GF1, GF2 and/or GF3 type tourism signs to indicate the area (not the individual facilities).

2 Painting and Drawing (see also generic symbol GFS A9):



GFS A9-1

Basic requirements:

- urban and peri-urban - within 2 km of the nearest numbered route;
- shall be open to visitors at least 6 days a week, for 52 weeks a year to qualify for a standard type of tourism sign (see paragraph 9.5.20.1 - Other aspects);
- visitor information and interpretive material, which may include live demonstrations of painting and/or drawing techniques, shall be available;

- access to, and touring of the facility, shall be disabled/elderly friendly;
- a wide variety of products shall be available and the majority of products, by type, shall have been produced on the premises or by the staff of the facility;
- the balance of material shall have been produced in South Africa or by South African artists.

Preferred requirements:

- a public telephone should be available;
- drinking water should be available;
- refreshments may be provided;
- seating should be provided;
- if the facility involves more than one building or covers a wide/landscaped area adequate pedestrian sign posting should be provided.

Other factors:

- if, for whatever reason, the facility is not open to visitors for the prescribed period, but qualifies for a **part time** tourism sign GF17, but can also be viewed by appointment, clear instructions should be available regarding the provision of a key (for a locked gate) or for access to a guide.

3 Pottery (see also generic symbol GFS A9):



GFS A9-2

Basic requirements:

- urban and peri-urban - within 2 km of the nearest numbered route;
- shall be open to visitors at least 6 days a week, for 52 weeks a year to qualify for a standard type of tourism sign (see paragraph 9.5.20.1 - **Other aspects**);
- adequate provision shall be made for the safety of visitors when they are in the vicinity of equipment, and for the security of their belongings whilst within the facility site;
- visitor information and interpretive material, which may include live demonstrations of pottery techniques, shall be available;
- access to, and touring of the facility, shall be disabled/elderly friendly;
- the principle activities related to the articles being produced shall occur under a roofed area;
- a wide variety of products shall be available and the majority of products, by type, shall have been produced on the premises or by the staff of the facility;
- the balance of material shall have been produced in South Africa or by South African crafts persons.

Preferred requirements:

- a public telephone should be available;
- drinking water should be available;
- refreshments may be provided;
- seating should be provided;
- if the facility involves more than one building or covers a wide/landscaped area adequate pedestrian sign posting should be provided.

Other factors:

- if, for whatever reason, the facility is not open to visitors for the prescribed period, but qualifies for a **part time** tourism sign GF17, but can also be viewed by appointment, clear instructions should be available regarding the provision of a key (for a locked gate) or for access to a guide.

4 Jewellery (see also generic symbol GFS A9):



GFS A9-3

Basic requirements:

- urban and peri-urban - within 2 km of the nearest numbered route;
- shall be open to visitors at least 6 days a week, for 52 weeks a year to qualify for a standard type of tourism sign (see paragraph 9.5.20.1 - **Other aspects**);
- adequate provision shall be made for the safety of visitors when they are in the vicinity of equipment, and for the security of their belongings whilst within the facility site;
- visitor information and interpretive material, which may include live demonstrations of jewellery making skills, shall be available;
- access to, and touring of the facility, shall be disabled/elderly friendly;
- the principle activities related to the articles being produced shall occur under a roofed area;
- a wide variety of products shall be available and the majority of products, by type, shall have been produced on the premises or by the staff of the facility;
- the balance of material shall have been produced in South Africa or by South African crafts persons.

Preferred requirements:

- a public telephone should be available;
- drinking water should be available;
- refreshments may be provided;
- seating should be provided;

- ❑ if the facility involves more than one building or covers a wide/landscaped area adequate pedestrian sign posting should be provided.

Other factors:

- ❑ if, for whatever reason, the facility is not open to visitors for the prescribed period, but qualifies for a **part time** tourism sign GF17, but can also be viewed by appointment, clear instructions should be available regarding the provision of a key (for a locked gate) or for access to a guide.

5 Weaving & Knitting (see also generic symbol GFS A9):



GFS A9-4

Basic requirements:

- ❑ urban and peri-urban - within 2 km of the nearest numbered route;
- ❑ shall be open to visitors at least 6 days a week, for 52 weeks a year to qualify for a standard type of tourism sign (see paragraph 9.5.20.1 - **Other aspects**);
- ❑ adequate provision shall be made for the security of visitors belongings whilst within the facility site;
- ❑ visitor information and interpretive material, which may include live demonstrations of weaving and/or knitting crafts, shall be available;
- ❑ access to, and touring of the facility, shall be disabled/elderly friendly;
- ❑ the principle activities related to the articles being produced shall occur under a roofed area;
- ❑ a wide variety of products shall be available and the majority of products, by type, shall have been produced on the premises or by the staff of the facility;
- ❑ the balance of material shall have been produced in South Africa or by South African crafts persons.

Preferred requirements:

- ❑ a public telephone should be available;
- ❑ drinking water should be available;
- ❑ refreshments may be provided;
- ❑ seating should be provided;
- ❑ if the facility involves more than one building or covers a wide/landscaped area adequate pedestrian sign posting should be provided.

Other factors:

- ❑ if, for whatever reason, the facility is not open to visitors for the prescribed period, but qualifies for a **part time** tourism sign GF17, but can also be viewed by appointment, clear instructions should be available regarding the provision of a key (for a locked gate) or for access to a guide.

6 Leatherwork (see also generic symbol GFS A9) :



GFS A9-5

Basic requirements:

- ❑ urban and peri-urban - within 2 km of the nearest numbered route;
- ❑ shall be open to visitors at least 6 days a week, for 52 weeks a year to qualify for a standard type of tourism sign (see paragraph 9.5.20.1 - **Other aspects**);
- ❑ adequate provision shall be made for the safety of visitors when they are in the vicinity of equipment, and for the security of their belongings whilst within the facility site;
- ❑ visitor information and interpretive material, which may include live demonstrations of leather making crafts, shall be available;
- ❑ access to, and touring of the facility, shall be disabled/elderly friendly;
- ❑ the principle activities related to the articles being produced shall occur under a roofed area;
- ❑ a wide variety of products shall be available and the majority of products, by type, shall have been produced on the premises or by the staff of the facility;
- ❑ the balance of material shall have been produced in South Africa or by South African crafts persons.

Preferred requirements:

- ❑ a public telephone should be available;
- ❑ drinking water should be available;
- ❑ refreshments may be provided;
- ❑ seating should be provided;
- ❑ if the facility involves more than one building or covers a wide/landscaped area adequate pedestrian sign posting should be provided.

Other factors:

- ❑ if, for whatever reason, the facility is not open to visitors for the prescribed period, but qualifies for a **part time** tourism sign GF17, but can also be viewed by appointment, clear instructions should be available regarding the provision of a key (for a locked gate) or for access to a guide.

7 **African Arts & Crafts** (see also generic symbol GFS A9) :

GFS A9-6

Basic requirements:

- urban and peri-urban - within 2 km of the nearest numbered route;
- shall be open to visitors at least 6 days a week, for 52 weeks a year to qualify for a standard type of tourism sign (see paragraph 9.5.20.1 - Other aspects@);
- adequate provision shall be made for the safety of visitors when they are in the vicinity of equipment, and for the security of their belongings whilst within the facility site;
- the arts and crafts shall be of an indigenous and historical African origin;
- visitor information and interpretive material, which may include live demonstrations of indigenous African artistic and craft techniques, shall be available;
- access to, and touring of the facility, shall be disabled/elderly friendly;
- a wide variety of products shall be available and the majority of products, by type, shall have been produced on the premises or by the staff of the facility;
- the balance of material shall have been produced in South Africa or by South African artists and crafts persons.

Preferred requirements:

- a public telephone should be available;
- drinking water should be available;
- refreshments may be provided;
- seating should be provided;
- if the facility involves more than one building or covers a wide/landscaped area adequate pedestrian sign posting should be provided.

Other factors:

- if, for whatever reason, the facility is not open to visitors for the prescribed period, but qualifies for a part time@ tourism sign GF17, but can also be viewed by appointment, clear instructions should be available regarding the provision of a key (for a locked gate) or for access to a guide.

8 **Woodwork** (see also generic symbol GFS A9):

GFS A9-7

Basic requirements:

- urban and peri-urban - within 2 km of the nearest numbered route;
- shall be open to visitors at least 6 days a week, for 52 weeks a year to qualify for a standard type of tourism sign (see paragraph 9.5.20.1 - Other aspects@);
- adequate provision shall be made for the safety of visitors when they are in the vicinity of equipment, and for the security of their belongings whilst within the facility site;
- visitor information and interpretive material, which may include live demonstrations of wood-working techniques, shall be available;
- access to, and touring of the facility, shall be disabled/elderly friendly;
- the principle activities related to the articles being produced shall occur under a roofed area;
- a wide variety of products shall be available and the majority of products, by type, shall have been produced on the premises or by the staff of the facility;
- the balance of material shall have been produced in South Africa or by South African crafts persons.

Preferred requirements:

- a public telephone should be available;
- drinking water should be available;
- refreshments may be provided;
- seating should be provided;
- if the facility involves more than one building or covers a wide/landscaped area adequate pedestrian sign posting should be provided.

Other factors:

- if, for whatever reason, the facility is not open to visitors for the prescribed period, but qualifies for a part time@ tourism sign GF17, but can also be viewed by appointment, clear instructions should be available regarding the provision of a key (for a locked gate) or for access to a guide.

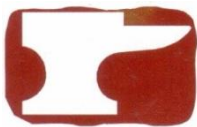
9 **Metalwork** (see also generic symbol GFS A9):

GFS A9-8

Basic requirements:

- urban and peri-urban - within 2 km of the nearest numbered route;
- shall be open to visitors at least 6 days a week, for 52 weeks a year to qualify for a standard type of tourism sign (see paragraph 9.5.20.1 - 'Other aspects');
- adequate provision shall be made for the safety of visitors when they are in the vicinity of equipment, and for the security of their belongings whilst within the facility site;
- a significant element of the workmanship shall involve hand crafting i.e. NOT mechanised or organised on a mass production basis.
- visitor information and interpretive material, which may include live demonstrations of metal-working techniques, shall be available;
- access to, and touring of the facility, shall be disabled/elderly friendly;
- the principle activities related to the articles being produced shall occur under a roofed area;
- a wide variety of products shall be available and the majority of products, by type, shall have been produced on the premises or by the staff of the facility;
- the balance of material shall have been produced in South Africa or by South African crafts persons.

Preferred requirements:

- a public telephone should be available;
- drinking water should be available;
- refreshments may be provided;
- seating should be provided;
- if the facility involves more than one building or covers a wide/landscaped area, adequate pedestrian sign posting should be provided.

Other factors:

- if, for whatever reason, the facility is not open to visitors for the prescribed period, but qualifies for a 'part time' tourism sign GF17, but can also be viewed by appointment, clear instructions should be available regarding the provision of a key (for a locked gate) or for access to a guide.

9.5.21 **Level 2 Warrant Criteria:**
Tourist Attractions: Group A10:
Cultural Attractions1 **Generic Cultural Attractions:**

GFS A10

This symbol may be used as a collective or generic symbol for a Cultural Attractions route (which may or may not be numbered as a Tourist Route), or to indicate a High Density Tourist Area with a 'cultural' theme, subject to compliance with the applicable warrants for a tourist route or HDTA, or any of the individual attractions within Group A10. In the latter two cases the applicable warrants will be those for a HDTA or those listed below.

2 **Theatre** (see also generic symbol GFS A10):

GFS A10-1

Basic requirements:

- urban and peri-urban - within 1 km of the nearest numbered route;
- shall have approved fire/emergency evacuation procedures including a clearly documented communication procedure for staff;
- shall have a minimum of 80 seats;
- shall submit reasonable documentation to support an expected programme of productions which will mean that the theatre is effectively open to the public for a minimum of 35 weeks a year (in reaching this aggregate productions do not need to run continuously from one to another);
- the premises shall be disabled/elderly friendly;
- a public telephone shall be provided.

Preferred requirements

- refreshments should be available.

3 **Amphitheatre** (see also generic symbol GFS A10):

GFS A10-2

Basic requirements:

- urban and peri-urban - within 1 km of the nearest numbered route;
- shall have a minimum of 80 seats;
- shall submit documentation to support an expected programme of at least 35 events in a year;
- shall be disabled/elderly friendly;
- a public telephone shall be available;
- drinking water shall be available.

Preferred requirements:

- refreshments should be available, or, if in a natural setting facilities for picnics/braais should be available.

must also be approved by the Department of Environmental Affairs and Tourism or its appointed agent;

- the trail shall be accessible to visitors 365 days a year, subject to severe weather and/or adverse environmental conditions;
- a map of the trail shall be readily available;
- there shall be a registration process to be complied with by hikers entering and leaving the trail;
- full details of the trail and the entry registration **process** shall be lodged with the appropriate emergency services;
- there shall be an information board at the start of the trail indicating (this may be repeated at strategic points along the trail):
 - where drinking water can be obtained;
 - the location of overnight stopping places;
 - hazardous areas;
 - emergency procedures to be followed.

9.5.22 Level 2 Warrant Criteria: Tourist Attractions: Group A11: Adventure Attractions

1 **Generic Adventure Attractions:**

Symbol design pending

This symbol may be used as a collective or generic symbol for an Adventure Attractions route (which may, or may not, be numbered as a Tourist Route), or to indicate a High Density Tourist Area with an Adventure theme, subject to compliance with the applicable warrants for a tourist route or HDTA, or for any of the individual attractions within Group A11. In the latter two cases the applicable warrants will be those for a HDTA or those listed below.

2 **Hiking Trail** (see also generic symbol GFS A11):

GFS A11-1

Basic requirements:

- urban and peri-urban - the start of the trail shall be within 5 km of the nearest numbered route;
- all hiking trails shall be approved by a recognised hiking association or club;
- if a hiking trail is within an environmentally sensitive area it

3 **Horse Trail** (see also generic symbol GFS A11):

GFS A11-2

Basic requirements:

- peri-urban - within 5 km of the nearest numbered route (if a horse trail is provided within an urban area the same criteria shall apply);
- environmental management principles, including particular attention to the potential for erosion on the trail and all access roads, shall be fundamental to all activities pertaining to the planning and use of horse trails;
- the trail shall be accessible to visitors 365 days a year, subject to severe weather and/or adverse environmental conditions;
- measures to ensure the safety and security of visitors and their belongings shall be fostered at all times;
- there shall be adequate signposting.

Preferred requirements:

- drinking water should be available;
- access to the trail and carriage riding, where practical, should be disabled/elderly friendly;
- visitor information such as interpretive brochures, displays and a visitors book should be provided;
- seating should be provided;
- the availability of wildlife viewing hides and view-points should be considered;
- the provision of camping/braai/picnic sites should be considered.

Other factors:

- if, for whatever reason, the horse trail is only accessible by appointment, or is kept locked, a guide should be available and clear instructions given for the collection and return of the key.

4 **4 x 4 Trail** (see also generic symbol GFS A11):



GFS A11-3

Basic requirements:

- peri-urban - the start of the trail shall be within 5 km of the nearest numbered route;
- all 4 x 4 trails shall be approved by a recognised 4 x 4 association or club;
- 4 x 4 trails shall not be located within or through environmentally sensitive areas;
- the trail shall be accessible 365 days a year, subject to severe weather and/or adverse environmental conditions;
- a map of the trail shall be readily available;
- there shall be an information board at the start of the trail indicating (this may be repeated at strategic points along the trail):
 - the rules and regulations pertaining to use of the trail (e.g. staying on the trail, no shooting, no littering, actions to be taken at rivers etc.);
 - drinking water availability;
 - the location of overnight stopping places;
 - up to date material about the trail accessibility and condition (related to recent/current weather and environmental conditions);
 - emergency procedures to be followed.

5 **Bike Trail** (see also generic symbol GFS A11):



GFS A11-4

Basic requirements:

- peri-urban - within 5 km of the nearest numbered route;
- all bike trails shall be approved by a recognised bike club;
- the trail shall be available at least two days a week 52 weeks a year;
- bike trails shall be subject to environmental management principles, including particular attention to the potential for erosion;

- a map of the area, indicating environmentally sensitive areas, shall be available and this shall be regularly updated with regard to such sensitive areas.

Preferred requirements:

- drinking water should be available;
- a brochure providing information on rules and environmental issues should be available.

Other factors:

- if, for whatever reason (e.g. private property), the bike trail is only accessible by appointment, or is kept locked, a guide should be available and clear instructions given for the collection and return of the key.

6 **River Rafting** (see also generic symbol GFS A11):



GFS A11-5

Basic requirements:

- peri-urban - within 10 km of the nearest numbered route;
- river rafting sites, and the access to them, shall be subject to environmental management principles during all planning and use activities;
- the site shall be available to users 365 days a year, subject to water levels and other environmental factors, and control by experienced rafters;
- a map or brochure of the river identifying all hazards and access points shall be available;
- there shall be an information board at all points of access to the river, indicating :
 - the rules and regulations pertaining to use of the river;
 - drinking water availability;
 - the location of overnight stopping places;
 - up to date material about the river conditions and specific hazards;
 - the quality of the river water for drinking purposes and /or required actions;
- emergency procedures to be followed.

7 **Scuba Diving** (see also generic symbol GFS A11);

GFS A11-6

Basic requirements:

- urban and peri-urban - within 5 km of the nearest numbered route;
- divers shall be required to provide proof of registration with an approved scuba diving association or club i.e. NAUI, SAUU, PADI or SSI;
- scuba diving sites shall be subject to environmental management principles during all planning and use activities;
- the site shall be available for at least 6 days a week, 52 weeks a year, subject to adverse weather conditions;
- information shall be provided by brochure, and/or information board indicating:
 - the rules and regulations pertaining to use of the site(s);
 - safety procedures;
 - emergency procedures to be followed.

Preferred requirements:

- diving equipment should preferably be available for hire;
- additional facilities such as charter dive boats and diving courses should preferably be available;
- adjacent accommodation and/or camping area (subject to appropriate warrants - see Subsection 9.5.32).

8 **Ballooning** (see also generic symbol GFS A11):

GFS A11-7

Basic requirements:

- peri-urban - a formal launch site shall be within 5 km of the nearest numbered route;
- launch sites shall be in regular use at least 2 days a week, 52 weeks a year subject to adverse weather conditions;
- information shall be provided by brochure and/or an information board indicating:
 - the rules and regulations pertaining to the use of balloons;
 - prevailing weather conditions;
 - safety requirements and known hazards e.g. power lines et;
 - emergency procedures to be followed.

Preferred requirements:

- drinking water should be available;
- seating and shade cover should be available.

9.5.23 Level 2 Warrant Criteria: Tourist Attractions: Group A12: Farming Attractions

1 **Generic Farming Attractions:**

GFS A12

Farming attractions are not likely to be common even in peri-urban areas although it is a feature of smaller towns that certain types of farming attraction occur around the fringes of the built-up area. The various warrants are therefore included here for completeness.

This symbol may be used as a collective or generic symbol for a Farming Attraction or Scenic Farming Route (which may, or may not, be numbered as a Tourist Route), or to indicate a High Density Tourist Area with a farming theme, subject to compliance with the applicable warrants for a tourist route or HDTA, or for any of the individual attractions within Group A12. In the latter two cases the applicable warrants will be those for a HDTA or those listed below.

2 **Wine Cellar** (see also generic symbol GFS A12):

GFS A12-1

Basic requirements:

- peri-urban - within 2 km of the nearest numbered route;
- environmental management principles in relation to the tourist activity shall be fundamental to all activities pertaining to the use of the resources;
- shall be open to day visitors for at least 8 hours per day for at least 5 days of the week and for at least 6 months of the year;
- shall incorporate a building with a wine tasting area where visitors may view a selection of the wines available for purchase;
- the wines sold shall have been manufactured or bottled on the premises;
- interpretive material on the wine making industry shall be available (see also Wine Route - GFS A12-2).

Preferred requirements:

- drinking water should be available;
- a public telephone should be available;
- seating should be provided and the premises should be disabled/elderly friendly;
- guided tours of the premises may be provided;
- the premises may incorporate a restaurant (subject to compliance with the appropriate warrants - see Subsection 9.5.28).

3 **Wine Route** (see also generic symbol GFS A12):



GFS A12-2

Basic requirements:

- peri-urban - the wine route, whether numbered as a tourist route or not, shall commence from a numbered navigational route (N, R or M prefix to the route number);
- shall be over public roads open 365 days a year;
- a route shall provide access to at least three vineyards which shall be open to the public for at least 6 hours per day for at least 5 days a week and for at least 6 months of the year.

Preferred requirements:

- the vineyards which are open to the public should provide at least the following:
 - the opportunity to tour the vineyard and a representative selection of the working buildings;
 - refreshments;
 - interpretive material regarding the wine industry.

4 **Showground** (see also generic symbol GFS A12):



GFS A12-3

Basic requirements:

- urban and peri-urban - within 2 km of the nearest numbered route;
- shall submit documentation to support an expected programme of at least 35 events in a year;
- shall be disabled/elderly friendly;
- a public telephone shall be available;
- drinking water shall be available.

Preferred requirements:

- refreshments and/or facilities for picnics/braais should be available.

5 **Cherry Farm** (see also generic symbol GFS A12):



GFS A12-4

Basic requirements:

- peri-urban - within 5 km of the nearest numbered route;
- environmental management principles in relation to the tourist activity shall be fundamental to all activities pertaining to the use of the resources;
- shall be open to day visitors for at least 6 hours per day for at least 5 days of the week and for at least 6 months of the year;
- cherry farming shall be the main activity of the farm;
- shall provide a building with reception/sales areas;
- interpretive material on the wine making industry shall be available (see also Wine Route - GFS A12-2).

Preferred requirements:

- drinking water, refreshments and/or facilities for picnics/braais should be available;
- guided tours through the cherry orchards should be offered.

6 **Ostrich Farm with Ostrich Riding** (see also generic symbol GFS A12):



GFS A12-5

Basic requirements:

- peri-urban - within 2 km of the nearest numbered route;
- shall be open to day visitors and shall offer rides/demonstration rides during at least a 6 hour period per day for 365 days a year, subject to weather conditions;
- the farm shall have approval to operate from a recognised animal protection group or the Zoological Society of Southern Africa, and shall be regularly inspected by such a group/society;
- environmental management principles, including responsible and sustained tourism development principles shall be fundamental to all activities pertaining to the use of the resources;
- shall have a clearly documented communication and emergency procedure to be followed by officials in the event of an incident;

- comprehensive visitor information, interpretive material, warnings against specific hazards, and procedures to be followed by the public in the event of an emergency shall be clearly displayed;
- shall provide a daily programme of awareness/ educational presentations;
- ostrich riding shall only occur within a designated area which minimises the risk of injury to the ostriches, riders and onlookers;
- ostrich riding shall only occur under the control of trained handlers and competent assistants;
- all ostrich products on sale shall comply with relevant health regulations (including regular inspections by health officials);
- visitor parking shall be separated a safe distance from ostrich viewing and riding areas;
- drinking water shall be available.

Preferred requirements:

- refreshments and/or facilities for picnics/braais should be available.

7 **Ostrich Farm** (see also generic symbol GFS A12):



GFS A12-12-6

Basic requirements:

- all requirements for GFS A12-5, with the exception of those related to ostrich riding, shall be complied with.

8 **Fish Farm** (see also generic symbol GFS A12):

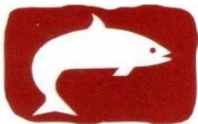

GFS A12-7

Basic requirements:

- peri-urban - within 2 km of the nearest numbered route;
- shall be open to visitors at least 6 hours per day for 365 days a year;
- environmental management principles, including responsible and sustained tourism development principles shall be fundamental to all activities pertaining to the use of the resources;
- shall provide comprehensive visitor information, interpretive material and daily awareness/ educational presentations;
- drinking water shall be available.

9 **Roadside Stall** (see also generic symbol GFS A12):



GFS A12-8

Basic requirements:

- peri-urban - subject to road authority approval a roadside stall selling farm produce may be located immediately adjacent to any class of road other than a Class AA@ road;
- shall be open to the public for 8 hours a day 365 days a year, unless the produce is of a seasonal nature, in which case the stall shall be open to the public on a daily basis for at least 6 months of the year;
- the lay-by serving such a roadside stall shall:
 - be sufficiently set back from the edge of the roadway to be safe;
 - be provided with a permanent surface;
 - provide for a minimum of 5 visitors vehicles at one time, subject to road authority requirements for a larger number of spaces;
- the produce on sale shall have been produced on the farm on which, or adjacent to which, it is located.

Preferred requirements:

- drinking water should be available;
- seating and shade should be provided.

10 **Butterfly Farm** (see also generic symbol GFS A12):



GFS A12-9

Basic requirements:

- peri-urban - within 5 km of the nearest numbered route;
- shall be open to visitors for at least 6 hours per day for at least 5 days a week for 365 days a year;
- environmental management principles, including responsible and sustained tourism development principles shall be fundamental to all activities pertaining to the use of the resources;
- shall provide comprehensive visitor information, interpretive material and daily awareness and/or educational presentations.

Preferred requirements:

- drinking water should be available;
- seating and shade should be provided.

9.5.24 Level 2 Warrant Criteria: Tourist Attractions: Group A13: General Attractions

1 Generic General Attractions:

Symbol design pending

This symbol may be used for any previously identified class of tourist attraction, or, for any tourist attraction which either cannot be easily allocated to an existing class or which caters for a wide variety of tourist attraction types. Otherwise the principle characteristics of a General Attraction are that it is visited primarily by tourists for pleasure and/or relaxation, and that tourists visit in sufficient numbers, and from sufficiently far away from the area of the attraction, that a tourism sign is justified on the grounds of traffic generation.

Basic Requirements:

- as with all tourist attractions the requirements of Subsections 9.5.11 and 9.5.12 shall be complied with;
- urban and peri-urban - within 2 km of the nearest numbered route;
- the general attraction shall be open to visitors 365 days a year;
- environmental management principles in relation to the tourist activity shall be fundamental to all activities pertaining to the use of the resources;
- if the general attraction involves fauna it shall have approval to operate from a recognised animal protection group or the Zoological Society of Southern Africa, and shall be regularly inspected by such a group/society;
- comprehensive visitor information, interpretive material, warnings against specific hazards, and procedures to be followed by the public in the event of an emergency shall be clearly displayed;
- measures to ensure the safety and security of visitors and their belongings shall be fostered at all times;
- drinking water shall be available.

Preferred requirements:

- the facility should be disabled/elderly friendly;
- seating should be provided;
- the provision of refreshments and/or picnic/braai sites should be considered.

2 Animal Theme Park:



GFS A13-1

Basic requirements:

- urban and peri-urban - within 2 km of the nearest numbered route;
- the theme park shall be open to visitors 365 days a year;
- environmental management principles in relation to the tourist activity shall be fundamental to all activities pertaining to the use of the resources;
- the theme park shall have approval to operate from a recognised animal protection group or the Zoological Society of Southern Africa, and shall be regularly inspected by such a group/society;
- comprehensive visitor information, interpretive material, warnings against specific hazards, and procedures to be followed by the public in the event of an emergency shall be clearly displayed;
- measures to ensure the safety and security of visitors and their belongings shall be fostered at all times;
- drinking water shall be available.

Preferred requirements:

- the facility should be disabled/elderly friendly;
- seating should be provided;
- the provision of refreshments and/or picnic/braai sites should be considered.

9.5.25 Level 2: Warrant Criteria: Emergency Services: Group B1:

1 Telephone:



GFS B1-1

Basic Requirements:

- urban - within 1 km of the nearest numbered route;
- shall be accessible 24 hours per day 365 days per year.

2 Police:



GFS B1-2(RSA)

Basic Requirements:

- urban - within 5 km of the nearest numbered route;
- shall be open 24 hours per day 365 days per year.

3 Hospital:



GFS B1-3

Basic Requirements:

- urban - generally within 5 km of the nearest numbered route, but in metropolitan areas the signing of hospitals should be planned, co-ordinated and implemented, in conjunction with the hospitals, to provide the best possible 24 hour emergency service accessibility for road users;
- a casualty or emergency facility shall be open 24 hours per day 365 days per year.

4 First Aid:



GFS B1-4

Basic Requirements:

- urban - generally within 2 km of the nearest numbered route (see note under GFS B1-3: Hospitals);
- shall be open 10 hours per day 365 days per year.

5 SOS Telephones:



GFS B1-5

Basic Requirements:

- when a system is installed signs shall be provided.

NOTE: Symbol GFS B1-6 is a variation of symbol GFS B1-5 for use on the actual phone installation.

9.5.26 Level 2 Warrant Criteria: Vehicle Services: Group B2:

- 1 All light vehicle service facilities considered for the provision of a tourism service sign shall provide a photocopy of a current trading/operating licence and shall be inspected for compliance with the following criteria by staff of the Automobile Association of South Africa:

2 Filling Station and Workshop:



GFS B2-1

Basic requirements:

- the premises and operation shall be in accordance with statutory requirements of local and other authorities with regard to planning, construction, water supply, sewage disposal, garbage collection and disposal, fire precautions and general safety;
- urban and peri-urban - within 500m of the nearest numbered route, provided:
 - there has been no qualifying filling station, or filling station and workshop, accessible from the same numbered route within 5 km of the junction under consideration for a sign;
 - there is no closer service station at the junction under consideration for a sign;
- the facility shall be open as a filling station 24 hours per day 365 days per year (subject to compliance with any national controls exercised from time to time);
- shall have at least six fuel outlet points in urban areas;
- all fuel pumps shall be covered by a canopy;
- the standing area for vehicle refuelling shall have a permanent surface;
- the active area of the facility shall be illuminated at night;
- water and air shall be available during the period that fuel is sold;

- ❑ toilet facilities of an acceptable standard shall be available for sale during normal office hours;
- ❑ a workshop suitable for the repair of all makes and models of popular light vehicle shall be provided;
- ❑ a qualified mechanic trained to repair all makes and models of popular light vehicle shall be available during normal office hours (minimum 8 hours), and be on stand-by for calls after hours;
- ❑ an acceptable range and number of the most necessary spare parts likely to be required by a long distance driver shall be available for all makes and models of popular light vehicle (e.g. fan belts, tyres, tubes, water pipes, windscreen wipers, batteries etc.).

3 **Filling Station:**



GFS B2-2

Basic requirement:

- ❑ the premises and operation shall be in accordance with statutory requirements of local and other authorities with regard to planning, construction, water supply, sewage disposal, garbage collection and disposal, fire precautions and general safety;
- ❑ urban and peri-urban - within 500m of the nearest numbered route, provided:
 - there has been no qualifying filling station, or filling station and workshop, accessible from the same numbered route within 5 km of the junction under consideration for a sign;
 - there is no closer service station at the junction under consideration for a sign;
- ❑ the facility shall be open as a filling station 24 hours per day 365 days per year (subject to compliance with any national controls exercised from time to time);
- ❑ shall have at least six fuel outlet points in urban areas;
- ❑ all fuel pumps shall be covered by a canopy;
- ❑ the standing area for vehicle refuelling shall have a permanent surface;
- ❑ the active area of the facility shall be illuminated at night;
- ❑ water and air shall be available during the period that fuel is sold;
- ❑ toilet facilities of an acceptable standard shall be available to the public during the period that fuel is sold (see Subsection 9.5.12 for details of "acceptable standard");
- ❑ a telephone shall be available to the public during the period that fuel is sold;

- ❑ road maps of an area in which the facility is situated shall be available for sale during normal office hours;
- ❑ an acceptable range and number of the most necessary spare parts likely to be required by a long distance driver shall be available for all makes and models of popular light vehicle (e.g. fan belts, tyres, tubes, water pipes, windscreen wipers, batteries etc.).

4 **Workshop:**



GFS B2-3

Basic Requirements:

- ❑ a workshop suitable for the repair of all makes and models of popular light vehicles shall be provided;
- ❑ urban and peri-urban - within 500m of the nearest numbered route, provided:
 - there has been no qualifying filling station, or filling station and workshop, accessible from the same numbered route within 5 km of the junction under consideration for a sign;
 - there is no closer service station at the junction under consideration for a sign;
- ❑ a qualified mechanic trained to repair all makes and models of popular light vehicles shall be available during; normal office hours (minimum 8 hours), and be on stand-by for calls after hours;
- ❑ an acceptable range and number of the most necessary spare parts likely to be required by a long distance driver shall be available for all makes and models of popular light vehicle (e.g. fan belts, tyres, tubes, water pipes, windscreen wipers, batteries etc.);
- ❑ toilet facilities of an acceptable standard shall be available to the public (see Subsection 9.5.12 for details of "acceptable standard");
- ❑ a telephone shall be available to the public.

5 **Tow-In Service:**



GFS B2-4

Basic Requirements:

- ❑ urban - within 1 km of the nearest numbered route;
- ❑ the facility shall be available 24 hours per day 365 days per year.

9.5.27 Level 2 Warrant Criteria: Truck Rest and Service: Group B3:

1 Truck Services:

All truck service facilities considered for the provision of a tourism service sign shall provide a photocopy of a current trading/operating licence and shall be inspected for compliance with the following criteria by staff of the Road Freight Association (RFA) and/or NAPTO:



GFS B3-1

Basic Requirements:

- the premises and operation shall be in accordance with statutory requirements of local and other authorities with regard to planning, construction, water supply, sewage disposal, garbage collection and disposal, fire precautions and general safety;
- urban and peri-urban - within 500m of the nearest numbered route, provided:
 - there has been no qualifying filling station, or filling station and workshop, accessible from the same numbered route within 5 km of the junction under consideration for a sign;
 - there is no closer service station at the junction under consideration for a sign;
- the facility shall be open as a service for (trucks ONLY) 24 hours per day 365 days per year (subject to compliance with any national controls exercised from time to time);
- shall have at least four diesel outlet points;
- all fuel pumps shall be covered by a canopy;
- the standing area for vehicle refuelling shall have a permanent surface;
- the active area of the facility shall be illuminated at night;
- water and air shall be available during the period that fuel is sold;
- toilet facilities of an acceptable standard shall be available during the period that fuel is sold;
- a telephone shall be available during the period that fuel is sold;
- an acceptable number of the most necessary spare parts likely to be needed by long distance truckers shall be available;
- sufficient parking for at least ten trucks shall be available, free of charge, as rest stops 24 hours per day.

Optional Facilities:

if any of the following are provided to an acceptable standard the use of a primary name on the sign may be considered (see Level 3 warrants):

- at least six lettable chalets;
- suitable fireplaces for cooking purposes;

- suitable refreshment or take-away service (subject to compliance with the warrants given in Subsection 9.5.28).

9.5.28 Level 2 Warrant Criteria: Food Services: Group B4:

1 Restaurant:

all restaurant facilities considered for the provision of a tourism service sign shall provide a photocopy of a current trading/operating licence and shall be inspected for compliance with the following criteria:



GFS B4-1

Basic requirements:

- the premises and operation shall be in accordance with statutory requirements of local and other authorities with regard to planning, construction, water supply, sewage disposal, garbage collection and disposal, fire precautions and general safety;
- urban and peri-urban - within 1 km of the nearest national route;
- the facility shall be open 40 hours per week 52 weeks per year to serve lunch and dinner;
- light refreshments shall be available between normal mealtimes;
- the food shall be good quality, properly cooked and attractively presented;
- the service shall be efficient and courteous, and be given in both official languages, imparting an atmosphere of welcome and willingness to please;
- menus, in keeping with the establishment, should be displayed in a weatherproof frame outside the main entrance;
- menus shall be clean and pleasant to handle and shall be provided in both official languages and in sufficient number, and shall indicate prices, VAT and any extra charges;
- the dining area shall be suitably and adequately illuminated;
- ventilation, whether natural or mechanical, shall be capable of providing a continuous flow of fresh air to all areas;
- tables and seating shall be of quality and arrangement to permit customers and staff to circulate easily in the dining area; they shall be of adequate size to enable customers to dine in comfort;
- floors shall be clean and without dangerous steps, tears in carpets, vinyl tiles;
- decor shall be in good taste and in good clean condition;
- table appointments shall be of good quality (this includes cutlery, condiments, ashtrays, tablecloths, napkins, mats etc.);

- an adequate number of toilets shall be available for men and women and shall be clearly signed; these shall be in first class repair and shall be regularly inspected to ensure cleanliness and overall maintenance; there shall be adequate natural and artificial ventilation; attention will be paid to the ease of use by disabled persons;
- kitchen equipment shall be adequate and suitable for the type of catering provided; this covers cooking, food storage, and food preparation equipment; floors, walls and ceilings shall be of a suitable type to maintain the highest standards of hygiene; cooking utensils shall be of suitable design and properly stored; waste bins shall be covered and suitably located; yards and approach areas to the kitchen shall be maintained in the same hygienic condition;
- the restaurant shall be under the constant control of a competent manager or supervisor during operating hours;
- waiters/waitresses shall be properly trained in the service of food and, if appropriate, drink; they shall be friendly, clean, neat, tidy and pleasant in appearance;
- kitchen staff shall be competent and clean;
- indoor seating shall be provided for at least 20 persons.

2 Refreshments and Take-away:

All facilities providing refreshment and/or take-aways considered for the provision of a tourism service sign shall provide a photocopy of a current trading/operating licence and shall be inspected for compliance with the following criteria.



GFS B4-2



GFS B4-3

Basic requirements:

- the premises and operation shall be in accordance with statutory requirements of local and other authorities with regard to planning, construction, water supply, sewage disposal, garbage collection and disposal, fire precautions and general safety;
- urban and peri-urban - within 500 m of the nearest numbered route;
- the facility shall be open 12 hours per day 365 days per year;
- the food shall be of good quality, properly cooked and attractively presented;
- waiter/menu service shall be efficient, courteous, and clear, and in sufficient number, giving prices, VAT and any extra charges;
- the entire area shall be suitably and adequately illuminated;
- an adequate number of toilets shall be available for men and women and shall be clearly signed; these shall be in first class

repair and shall be regularly inspected to ensure cleanliness and overall maintenance;

- kitchen equipment shall be adequate and suitable for the type of catering provided; this covers cooking, food storage, and food preparation equipment; floors, walls and ceilings shall be of a suitable type to maintain the highest standards of hygiene; cooking utensils shall be of suitable design and properly stored; waste bins shall be covered and suitably located; yards and approach areas to the kitchen shall be maintained in the same hygienic condition;
- waiters/waitresses shall be properly trained in the service of food and, if appropriate, drink; they shall be friendly, clean, neat, tidy and pleasant in appearance;
- kitchen staff shall be competent and clean;
- indoor and/or outdoor seating shall be provided for at least 10 persons;
- a parking area adequate for at least 10 light vehicles shall be available (separate and adequately dimensioned parking may also or alternatively be provided for heavy vehicles).

9.5.29 Level 2 Warrant Criteria:
General Services: Group B5:

- 1 Certain of the services in Group B5 classified as "General Services" are not likely to be individually signposted in urban (or peri-urban) areas, except in circumstances unique to specific urban environments i.e. a shower near a beach in a coastal town. All services in the group are detailed here, however, for completeness.
- 2 All general service facilities shall have a clean, attractive and well- kept appearance, and shall be maintained in a good state of repair.
- 3 **Parking Area:**



GFS B5-1

Basic requirements:

- to qualify for the use of the symbol GFS B5-1 on a tourism sign the parking area concerned shall be free, and shall have been provided primarily for tourists (see definitions in Volume 2, Chapter 4, Section 4.8) - the equivalent symbols GDS-20 and GDLS A1-11 (or GDLS A1-12) should be used on DIRECTION or LOCAL DIRECTION signs when the parking is not free and/or is associated with a non-tourist related commercial operation (in this context the classification of the facility as "tourist" or "local" is relevant);
- urban - within 500 m of the nearest numbered route (this criterion may be varied when the point of access to parking has been located to suit an approved development plan);
- peri-urban - within 1 km of the nearest numbered route;

- parking shall be available at least 12 hours a day 365 days a year;
- measures to ensure the safety and security of visitors and their belongings shall be fostered at all times.

4 Toilets:



GFS B5-2

Basic requirements:

- to qualify for the use of symbol GFS B5-2 on a tourism sign the toilets concerned shall have been provided primarily for tourists (see definitions in Volume 2, Chapter 4, Section 4.8);
- urban - within 200 m of the nearest Class "B" or "C" road;
- peri-urban - within 500 m of the nearest Class "B" or "C" road;
- the toilets shall be open to tourists at all times that adjacent tourist attractions and/or services are open to tourists 365 days a year;
- toilets shall be available:
 - for both genders;
 - with adequate and suitable illumination;
 - with adequate natural and artificial ventilation;
 - subject to regular inspection for cleanliness and state of repair/maintenance;
 - shall have floor surfaces and levels that minimize any hazard.

5 Shower:



GFS B5-3

Basic requirements:

- to qualify for the use of symbol GFS B5-3 on a tourism sign the showers concerned shall have been provided primarily for tourists (see definitions in Volume 2, Chapter 4, Section 4.8);
- in an urban or peri-urban environment showers will almost certainly be associated with toilets in which case the service class tourism sign may display both symbols, otherwise distance warrants of 200 m (urban) and 500 m (peri-urban) from the nearest Class "B" or "C" road shall apply;
- the toilets shall be open to tourists at all times that adjacent tourist attractions and/or services are open to tourists 365 days a year;

toilets shall be available:

- for both genders;
- with adequate and suitable illumination;
- with adequate natural and artificial ventilation;
- subject to regular inspection for cleanliness and state of repair/maintenance;
- shall have floor surfaces and levels that minimize any hazard.

6 Drinkable Water:



GFS B5-4

Basic requirements:

- the need to sign "drinkable water" for drivers of vehicles is likely to be rare in an urban or peri-urban environment - should such a need arise a distance warrant of 200 m from the nearest Class "B" or "C" road should be considered.

7 Fireplace:



GFS B5-5

Basic requirements:

- the need to sign "fireplaces" for drivers of vehicles is likely to be rare in an urban or peri-urban environment - should such a need arise a distance warrant of 200 m from the nearest Class "B" or "C" road should be considered;
- any fireplaces provided for public use in an urban or peri-urban environment shall be kept in a clean and hygienic condition;
- firewood and/or gas cylinders shall be available;
- the fireplaces shall be provided with basic cover from rain or sun;
- each fireplace shall be provided with a rubbish bin.

8 **Cooking Facilities:**

GFS B5-6

Basic requirements:

- the need to sign "cooking facilities" for drivers of vehicles is likely to be rare in an urban or peri-urban environment - should such a need arise a distance warrant of 200 m from the nearest Class "B" or "C" road should be considered;
- any cooking facility provided for public use in an urban or peri-urban environment shall be kept in a clean and hygienic condition;
- firewood and/or gas cylinders shall be available;
- the cooking facility shall be provided with basic cover from rain or sun;
- each cooking facility shall be provided with a rubbish bin.

9 **Picnic Area:**

GFS B5-7

Basic requirements:

- urban and peri-urban - within 2 km of the nearest numbered route;
- the picnic area shall be open to public 365 days a year;
- adequate and scenic parking shall be provided;
- an adequate number of toilets complying with the requirements for GFS B5-2 shall be provided;
- drinking water shall be available;
- adequate rubbish bins shall be provided;

Preferred requirements:

- cooking/braai facilities complying with the requirements for GFS B5-6 should be provided if practical;
- the facility should be disabled/elderly friendly.

10 **Tourist Information:**

GFS B5-8

Basic Requirements:

- to qualify for the use of symbol GFS B5-8 on a tourism sign the information centre, bureau or lay-by shall have been provided primarily for tourists (see definition in Volume 2, Chapter 4, Section 4.8) - the equivalent symbol GDLS A2-1 should be used on LOCAL DIRECTION signs when the information available is of a more general nature and symbol/sign IN12 should be used to identify such a general information centre;
- urban and peri-urban - within 1 km of the nearest numbered route;
- essential information shall be displayed in such a way that it is available 24 hours a day 365 days a year;
- a public telephone shall be available.

Preferred requirements:

- information centres and bureaux should be staffed by one or more persons with extensive and detailed knowledge of the area, and the tourist attractions and services within the area;
- an information centre, bureau or lay-by should hold adequate stocks of maps and brochures for the localised area, the province, and South Africa as a whole;
- an information lay-by may be established at other tourist facilities such as filling stations, rest and service areas and picnic areas.

11 **Facilities for Handicapped Persons:**

GFS B5-9

Basic requirements:

- an urban or peri-urban authority should identify those facilities for handicapped persons within central business districts and other high density areas which should be signed;
- these same authorities shall approve signs indicating facilities for handicapped persons in or close to other centres of activity, subject to assessment by a representative of the South African Paraplegic Association or similar representative body;
- urban and peri-urban - within 2 km of the nearest numbered route.

12 **Roadside Stall:**

GFS B5-10

Basic requirements:

- peri-urban - subject to road authority approval a roadside stall selling products of interest to tourists may be located immediately adjacent to any class of road other than a Class A road;
- shall be open to the public for 8 hours a day 365 days a year;
- the lay-by serving such a roadside stall shall :
 - be sufficiently set back from the edge of the roadway to be safe;
 - be provided with a permanent surface;
 - provide for a minimum of 5 visitors vehicles at one time, subject to road authority requirements for a larger number of spaces;
- the products on sale shall primarily have been produced locally, although products from elsewhere in South Africa may also be sold.

Preferred requirements:

- drinking water should be available;
- seating and shade should be provided.

13 **Post Office:**

GFS B5-11

Basic requirements:

- to qualify for the use of symbol GFS B5-11 on a tourism sign the post office shall be located in an area frequented by tourists (see definitions in Volume 2, Chapter 4, Section 4.8) - such a sign may also be relevant on the fringes of a smaller town by-passed by a numbered route - the equivalent symbol GDLS A 2-2 should be used on LOCAL DIRECTION sign when the post office is a normal community-based facility with no significant tourist clientele;
- urban - within 500 m of the nearest Class "B" or "C" road;
- peri-urban - within 1 km of the nearest Class "B" or "C" road;
- shall be open to the public during normal office hours;
- one or more telephones shall be available 24 hours a day 365 days a year;
- a post box shall be available 24 hours a day 365 days a year, on which the collection times are clearly indicated.

14 **Rural Shop/Cafe/Corner Shop**

GFS B5-12

Basic requirements:

- peri-urban - within 500 m of a Class "B" or "C" road;
- shall be open 365 days a year;
- shall have parking for at least 5 vehicles;
- shall sell drinks and light refreshment.

Preferred requirements:

- should be a tourist information agent.

9.5.30 Level 2 Warrant Criteria: Rest and Service Areas: Group B6:

1 **Rest Area Class 1:**

GFS B6-1

Basic requirements:

- tree shade;
- rubbish bin;
- table and bench.

2 **Service Area Class 2:**

GFS B6-2

Basic requirements:

- roofed shade;
- toilets;
- braai;
- rubbish bins;
- tables and benches.

3 **Service Area Class 3:**

GFS B6-3

Basic requirements:

- roofed shade;

- toilets;
 - braai;
 - rubbish bins;
 - tables and benches;
 - fuel;
 - restaurant(s) for light and heavy vehicle drivers and passengers;
- 4 In addition the following criteria shall apply:
- (a) fuel and restaurant facilities shall comply with warrants for these types of facilities;
 - (b) a wide range of additional facilities may be provided;
 - (c) the facility may qualify for the use of a primary name on the tourism signs provided (see Subsection 9.5.33, paragraph 9.5.33.1 (a)).

9.5.31 Level 2 Warrant Criteria: Vehicle Class: Group B7:

- 1 This class of facility shall ONLY apply if a rest, service, or rest and service area has different access points for different classes of vehicle. This type of access arrangement is not generally recommended.



GFSB7-1
Motor Cars



GFS B7-2
Caravans



GFS B7-3
Buses



GFS B7-4
Trucks

9.5.32 Level 2 Warrant Criteria: Accommodation: Group C1:

- 1 All accommodation facilities considered for the provision of a tourism service sign shall provide a photocopy of a current trading/operating licence and shall be inspected for compliance with the following criteria by staff of a Regional Tourism Body at regular intervals. The following are working definitions used in the past by SATOUR and which should continue to be used as a basis for determining certain classes of accommodation:
- (a) Hotel - "A Hotel is a purpose built building which provides lodging, meals and beverages and is accessible to the public";
 - (b) Chalet/Self-catering Establishment - "Establishments participating in the self-catering category shall consist of at least four units and shall **have an owner/manager on the premises**. This category shall include timeshare apartments, game parks, holiday resorts etc";
 - (c) Guest House - "A Guest House is an **owner managed** commercial accommodation establishment of not less than 4 and not more than 16 bedrooms, and which has as its

primary source of business, the supply of tourist accommodation and a substantial breakfast for resident guests, and the provision of a substantial dinner where such facilities are not readily available in the vicinity";

- (d) Bed and Breakfast - "Bed and Breakfast is an informal, irregular accommodation operation undertaken from a **private dwelling**";

(e) Youth Hostel - Provide lodging for youth travellers.

- 2 The provision of tourism signs for accommodation facilities in urban areas needs to be addressed on an holistic basis. For example in a large holiday city there will be a real physical difficulty in locating all the signs that could, theoretically, be required by accommodation which complies with warrants. On the other hand a smaller town may only have one or two hotels, well separated from each other. Many towns and cities may in fact have both of these circumstances. It is therefore recommended that, notwithstanding individual compliance with warrants, a clearly stated and recorded policy be adopted by the town or city council specific to the signing of accommodation facilities.

- 3 The following factors are relevant to the determination of such a policy.

(a) if there are large concentrations of accommodation facilities within a definable area the principles relating to High Density Tourism Areas may be adopted for signing purposes e.g.. TOURISM DIRECTION signs identifying a "North Beach" area from a "South Beach" area (in this sort of situation it will help the effectiveness of the signs if the hotels in the area are encouraged to identify themselves, on their stationery for instance, with "North Beach" or "South Beach"); in terms of such an approach, individual signs should not be provided for specific facilities, unless there is some very unique feature relating to the access to the facility, which, on safety grounds, requires the provision of a final turn sign GF3;

(b) an alternative to the above treatment, particularly when the number of accommodation facilities may still be high, but not so densely concentrated, may be to create a number of strategically located information centres, bureaux or lay-bys with detailed information facilities; technological advances are such that a print-out of the route to be taken to a specific hotel, guest house etc., could be obtainable at such an information centre;

(c) when the concentration of accommodation facilities is such that they are well spaced, a more conventional approach to signing, based on the warrants below, should be followed taking note particularly of the basic requirements covered in Subsection 9.5.10 (the formal recording of policy is particularly important if a town or city will use more than one of the above approaches because the provision of a sign in terms of (c) will be seen to be a precedent for a facility to be covered in terms of (a) or (b)).

- 4 A distance warrant is only really appropriate, therefore, in a suburban or peri-urban environment. The following warrants are proposed for all classes of accommodation unless noted otherwise:

- urban and suburban - within 500 m of the nearest Class "B" or "C" road, whichever is the nearer;
- peri-urban - within 1 km of the nearest numbered route.

5 Hotels, Motels, Inns and Lodges:



GFS C1-1

Basic requirements:

- quality graded and/or inspected and recommended;
- the premises and operation shall be in accordance with statutory requirements of local and other authorities with regard to planning, construction, water supply, sewage disposal, garbage collection and disposal, fire precautions, access and general safety;
- reception facilities shall be available 12 hours per day 365 days per year, with the capability to accept, by prior arrangement, arrivals 24 hours per day;
- breakfast and beverages shall be provided;
- premises shall be clean;
- premises shall be well kept in a good state of repair;
- a brochure should be available.

6 Chalet/Self Catering Establishments:



GFS C1-2

Basic requirements:

- graded and/or inspected and recommended;
- the premises and operation shall be in accordance with statutory requirements of local and other authorities with regard to planning, construction, water supply, sewage disposal, garbage collection and disposal, fire precautions, access and general safety;
- reception facilities shall be available 12 hours per day 365 days per year, with the capability to accept, by prior arrangement, arrivals 24 hours per day;
- shall be available primarily for the lodging or sleeping of travellers with or without booking;
- shall have well maintained access and internal roads;
- shall provide self-catering facilities;
- shall have a minimum of 4 accommodation units, with bathroom facilities, separate access and individual parking (i.e. not inter-leading);

- each chalet shall contain furniture, cupboard space, fittings and equipment of acceptable standard, quality and condition, for sleeping and toilet purposes;
- a brochure should be available.

7 Caravan Parks and/or Camping Sites:



GFS C1-3



GFS C1-4

Basic requirements:

- the premises and operation shall be in accordance with statutory requirements of local and other authorities with regard to planning, construction, water supply, sewage disposal, garbage collection and disposal, fire precautions, access and general safety;
- quality graded and/or inspected and recommended;
- urban and peri-urban - within 5 km of the nearest numbered route;
- reception facilities shall be available 12 hours per day 365 days per year, with the capability to accept, by prior arrangement, arrivals 24 hours per day;
- the facility shall have at least 20 sites;
- at least 20% of sites shall be available to short-term visitors including single night visits;
- there shall be adequate space between sites and internal facilities such as ablution blocks;
- ablution blocks or any other structures shall be provided with adequate natural and/or artificial lighting and natural and/or artificial ventilation;
- hot and cold water shall be available during all reasonable hours;
- the premises shall be under the regular supervision of a responsible person capable of maintaining order and control;
- the premises shall be adequately staffed to maintain the above services at all times;
- a brochure should be available.

8 Guest House:



GFS C1-5

Basic requirements:

- quality accredited and/or inspected and recommended;
- reception facilities shall be available 12 hours per day 365 days per year, with the capability to accept, by prior arrangement, arrivals 24 hours per day;
- parking shall be to an adequate standard;
- accommodation of 4 bedroom-en-suite (or private bathroom) shall be available;
- meals shall be provided (self-catering facilities shall not be provided);
- dining room facilities shall be available;
- a brochure should be available;
- each room shall contain furniture, lighting, cupboard space, fittings and equipment of acceptable standard, quality and condition, for sleeping.

Preferred requirement:

- the premises and operation should preferably be a registered business run in accordance with statutory requirements of local and other authorities with regard to planning, construction, water supply, sewage disposal, garbage collection and disposal, fire precautions, access and general safety.

9 Bed and Breakfast and Rooms:



GFS C1-6



GFS C1-7

Basic requirements:

- accredited and/or inspected and recommended;
- open for registration 12 hours per day, 365 days a year;
- premises should be clean and attractive and in good state or repair;
- available primarily for the lodging or sleeping of travellers;
- provision shall be made for bedding;
- a brochure should be available;
- parking should be provided;
- bathroom facilities shall not be shared with household;
- breakfast shall be provided in "B+B" facilities.

10 Youth Hostel:



GFS C1-8

Basic requirements:

- the hostel, when making application to its Municipality, must be in receipt of a letter from the Youth Hostel Association; the letter will confirm the hostel as being a member and as such, will meet the IYHFs International Operating Standards as mentioned, together with those listed below;
- the minimum number of beds shall be 10;
- the hostel must be clean and secure;
- the hostel must offer 24-hour check-ins;
- space between beds shall be adequate, and the number of toilets/bathrooms shall correlate to the number of people, as specified in the IYHF Operating Standards Manual;
- where bedding is not automatically provided, provision shall be made for this to be hired;
- the hostel shall be open throughout the year;
- sufficient parking should be available;
- the hostel shall either provide self-catering facilities or communal dining room facilities with meals.

11 Trail Shelter



GFS C1-9

Basic requirements:

- peri-urban - this symbol is only likely to be used within a trail (hiking, horse or bike) - as such it is recommended that the distance to the shelter, in metres, be included on the sign;
- the trail shelter shall be a short distance from a source of drinking water;
- a rubbish bin shall be provided;
- the shelter environs and rubbish bin(s) shall be regularly cleaned.

12 Guest Farm



GFS C1-10

Basic requirements:

- quality accredited and/or inspected and recommended;
- peri-urban - within 5 km of the nearest numbered route;

- reception facilities shall be available 12 hours per day 365 days per year, with the capability to accept, by prior arrangement, arrivals 24 hours per day;
- parking shall be to an adequate standard;
- accommodation of 4 bedroom-en-suite (or private bathroom) shall be available;
- meals shall be provided (self-catering facilities shall not be provided);
- dining room facilities shall be available;
- a brochure should be available;
- each room shall contain furniture, lighting, cupboard space, fittings and equipment of acceptable standard, quality and condition, for sleeping.

Preferred requirement:

- the premises and operation should preferably be a registered farm (or small-holding in a peri-urban environment); the availability of accommodation should be linked to interaction by visitors with the farming activities.

13 Ethnic (Zulu) Accommodation



GFS C1-11

Basic requirements:

- peri-urban - within 5 km of the nearest numbered route;
- the accommodation shall be registered with the Local Tourist Organisation/Publicity Association;
- shall be open for arrivals for 12 hours a day 365 days a year;
- parking shall be in close proximity to bedrooms;
- the premises shall be clean, neat and maintained in good condition;
- water-borne sewers to be provided;
- shower and toilet facilities for exclusive use of guests to be located close to bedrooms;
- continuous electrical or gas lighting to be available and lights to be provided with shades;
- clean linen, towels and soap to be provided for each letting;
- accommodation tariff to be displayed;
- curtains to be provided for all windows;
- door and windows to be provided with secure locks in working order;
- basic equipment of acceptable bedding, chairs, drinking glasses and non-plastic eating utensils to be provided for each guest;
- waste-paper basket and emergency candle/torch to be provided;
- if meals are not provided, an electric or gas cooker shall be provided, together with adequate cooking utensils.

Preferred requirements:

- the name and address of a local doctor and emergency service should be provided/available;
- mosquito repellent when appropriate.

9.5.33 Level 3 Warrant Criteria: Signface Design

1 The following are basic criteria which may warrant the use of the stated signface design principle on a tourism sign:

(a) Primary Name:

- tourist attractions;
- Class 3 rest and service area;
- grade 2 or higher accommodation;
- hospitals.

(b) Supplementary Symbols:

- the use of supplementary symbols is **not** appropriate for multi-facility venues such as national and provincial parks, and resorts - such facilities shall be required to make a choice and select one specific symbol to represent their principle interest;
- supplementary symbols are only appropriate for isolated tourist attractions (i.e. not closer than 5 km to a similar facility) where it would be **to the disadvantage of tourists** not to know the nature of the supplementary facilities offered;
- if the supplementary symbol is intended to indicate a category of accommodation, the accommodation shall be available to passing visitors without bookings; EXCEPT that the use of symbols GFS C1-1 (bed) and GFS B4-1 (knife and fork) **only** as supplementary symbols located below a PRIMARY NAME represents a standard **alternative** signface layout for accommodation facilities offering restaurant facilities in accordance with the individual warrants (the purpose of the alternative is to offer a reduced sign size under certain signface detail circumstances (see Volume 4, Chapter 7)).

(c) "Area" Collective Symbol:

- the use of an "Area" collective symbol is recommended whenever possible to reduce the total signface area of a collective sign installation for a number of tourist facilities;
- the concept of "Collective" symbols is dealt with in some detail in Volume 2, Chapter 4, Section 4.4.

(d) A Distance:

- if the distance is greater than might be expected;
- if road condition is poor;
- if the distance is greater than 20 km;
- if road is a "dead-end" road over 2 km in length

(e) A Route Number:

- if facility is the only public destination on a numbered route or it is located on a numbered tourist route i.e. T2.

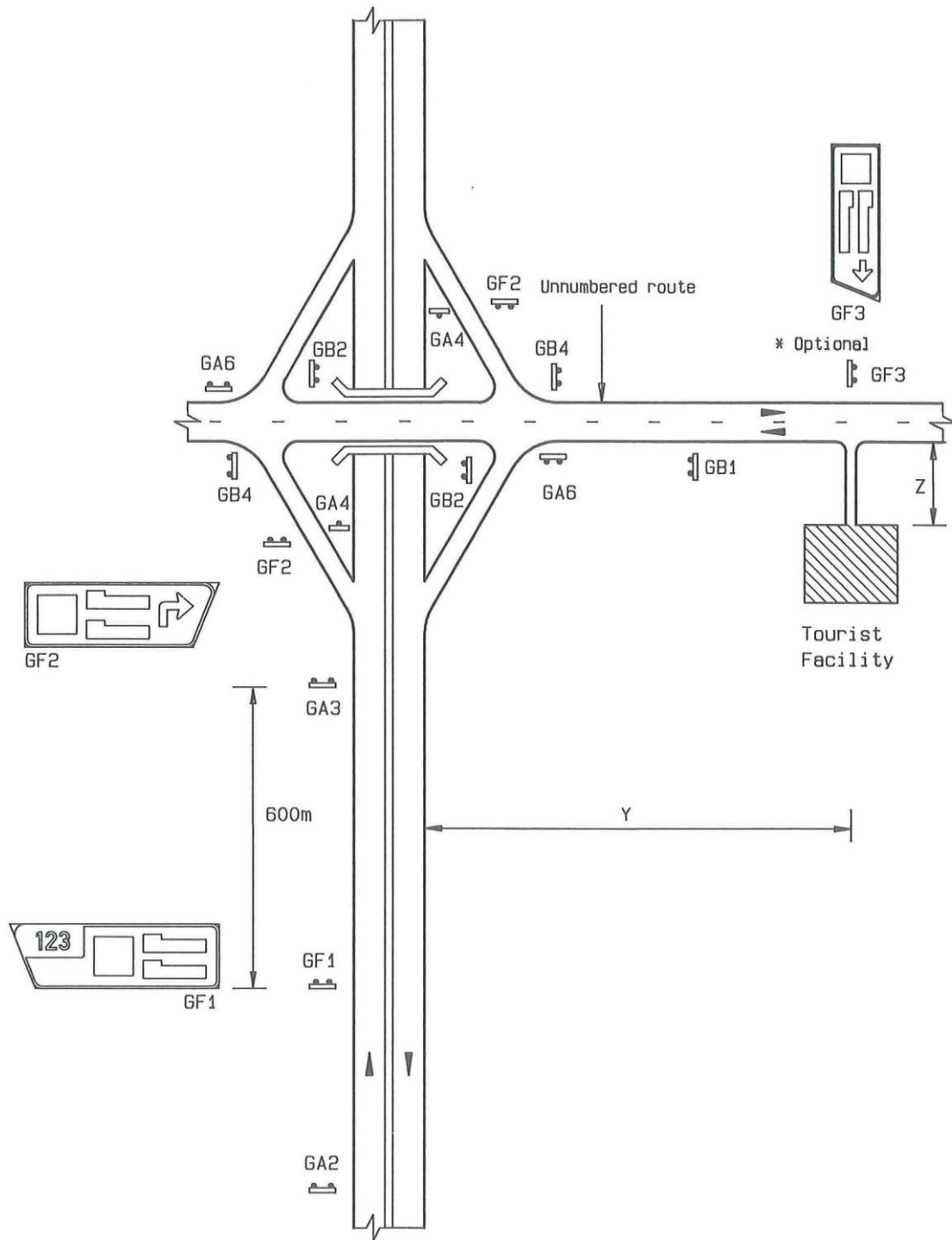

2017

Reproduc

Fig 9.33

Supplementary Tourist Direction Signing – Urban Class “A” Routes

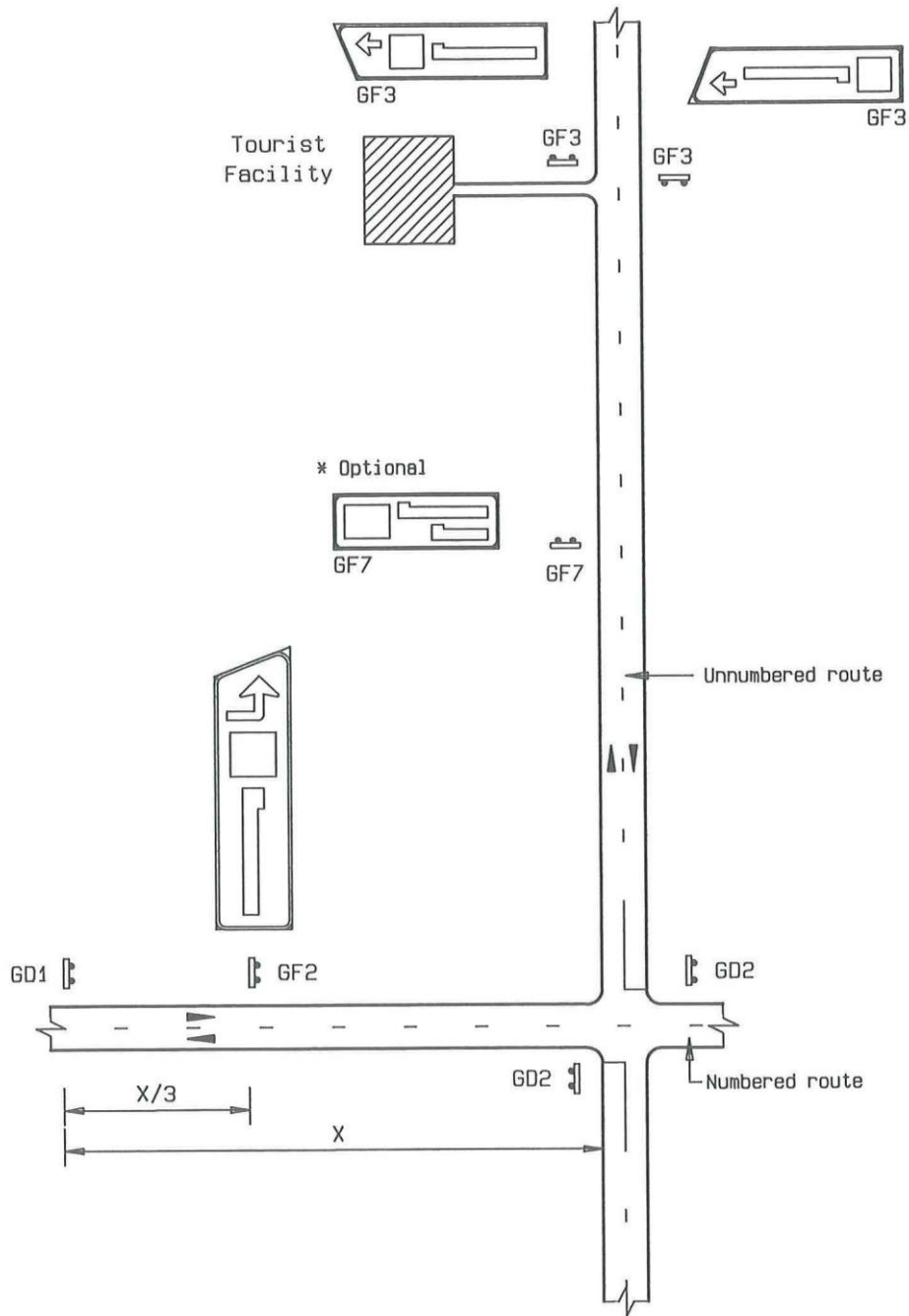

th July 2017

Reproduced unauthorised

Fig 9.34

Basic Supplementary Tourist Direction Signing – Urban Class "B" Routes

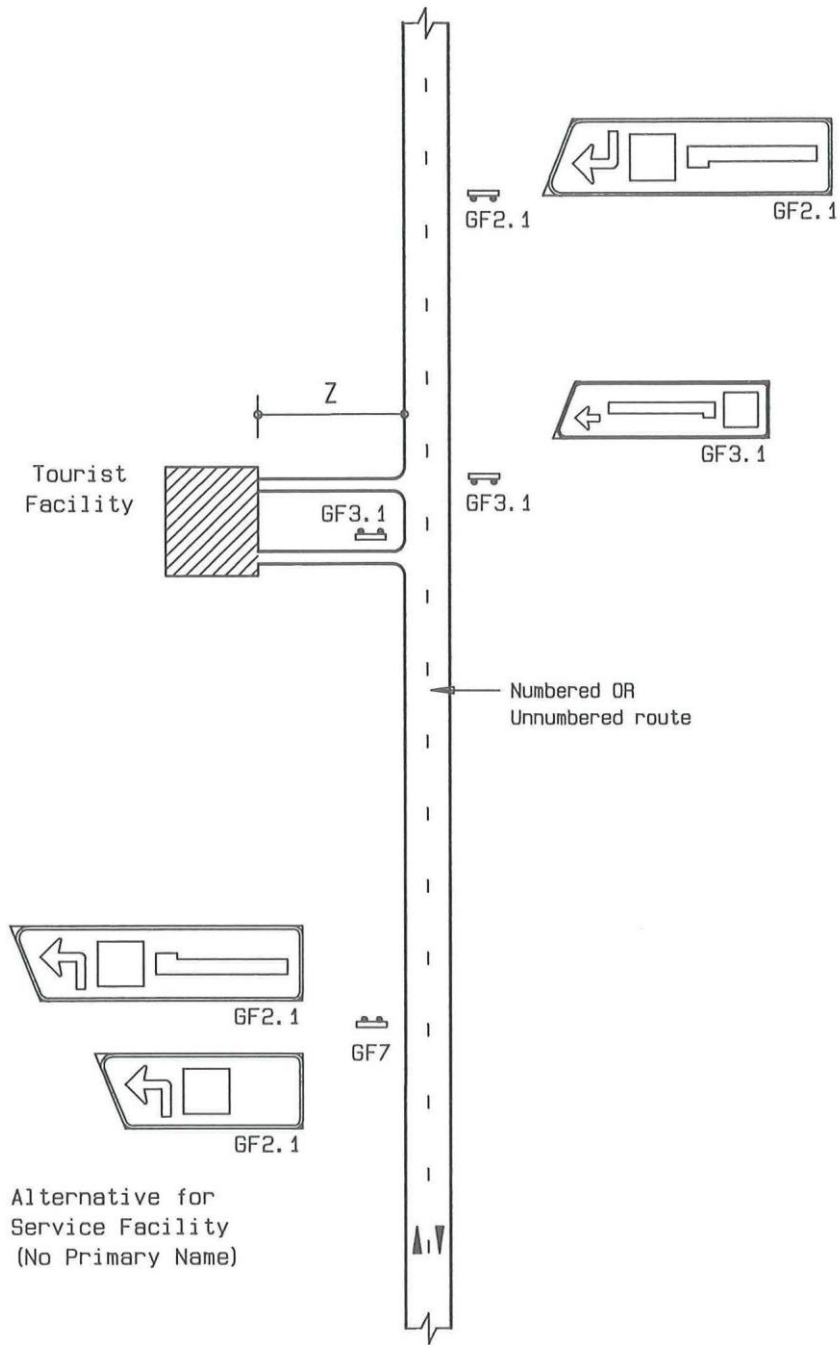
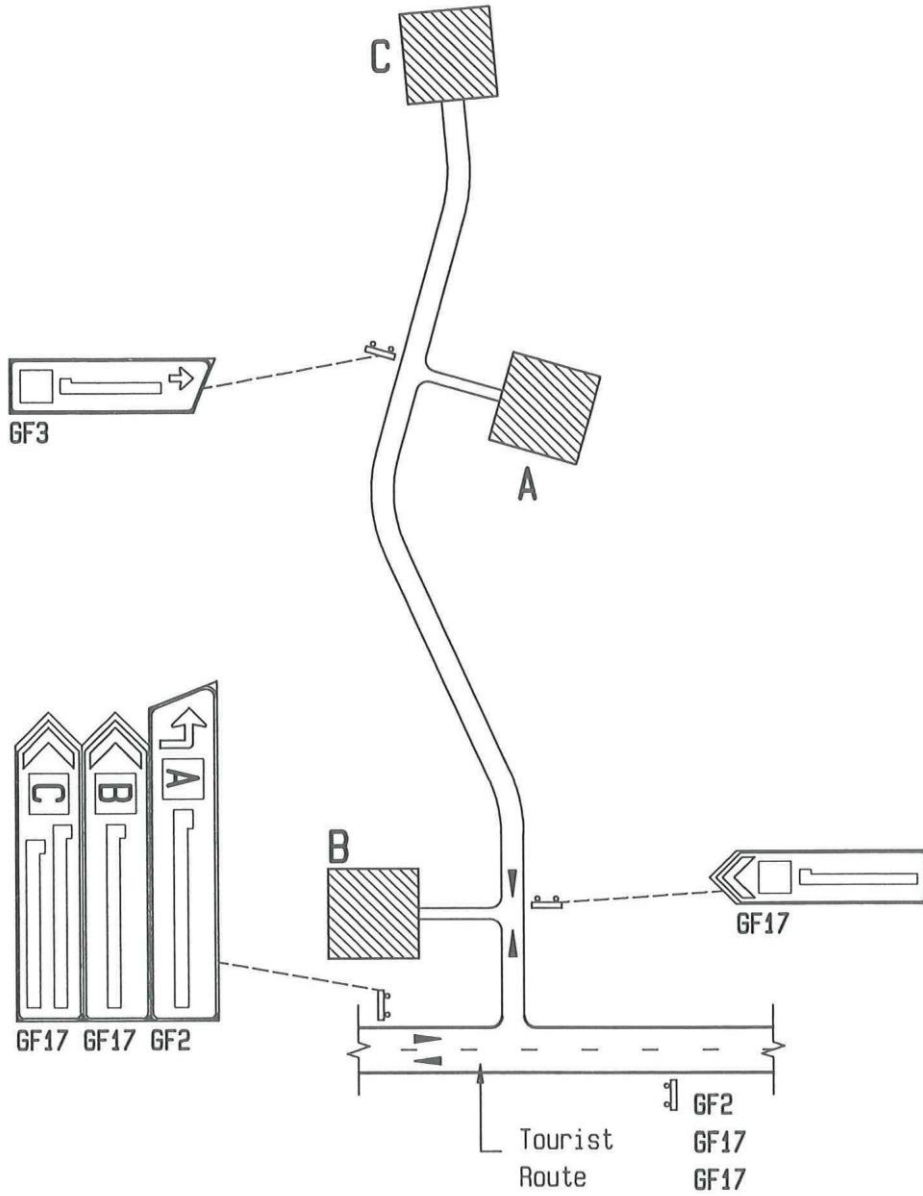

Fig 9.35

Basic Supplementary Tourist Direction Signing – Final Turn



July 2017

Reproduced under Gov

Fig 9.36

Basic Supplementary Tourist Direction Signing – From an Urban/Peri-Urban Tourist Route

9.6 APPLICATIONS OF URBAN GUIDANCE SIGNING

9.6.1 General

1 This Section provides a wide range of examples of typical urban guidance signing sequences. In particular each of the signing levels identified in Subsection 9.3.9 and Figure 9.15 are illustrated.

2 It is very possible that a signing situation will arise which is not specifically covered. A solution to such a problem is almost certain to be available by combining aspects of two or more of the given examples. It should also be noted that further examples of guidance sign applications can be found as follows:

- (a) Chapter 4: *Tourism Signing*;
- (b) Chapter 5: *Freeway Signing*;
- (c) Chapter 10: *Rural Signing*.

9.6.2 Applications of Location Signs

1 In the urban context the most important LOCATION signs are:

- (a) STREET NAME signs GL1;
- (b) SUBURB NAME signs GL2;
- (c) TOWN or CITY NAME signs GL3.

2 Factors which affect the installation of a specific street name sign are:

- (a) is the street name to appear on a DIRECTION sign GD2?
- (b) its position within the junction - the far left corner is the recommended position;
- (c) visibility in the chosen position;
- (d) is letter size adequate for legibility?
- (e) a special need for long range legibility e.g. in advance of a junction or in an elevated position.

3 Details relevant to the above factors are illustrated in Figure 9.37 and a detailed arrangement of street name sign positions is shown in Figure 9.38 with respect to a network of routes and streets. Examples of specific street name sign mounting problems are further given in Figure 9.39.

4 Although not road traffic signs, property identification signs or street numbers are the ultimate for of LOCATION sign, in the sense that they say "You are here" at the end of a journey. Limited guidelines for effective property identification signs are given in Section 9.7.

9.6.3 Applications of Route Marker and Trailblazer Signs

1 Route marker signs should comprise the major part of a minimum or short term signing plan. They may be provided to one of two levels, namely:

- (a) as a full "set" for each approach on a Class "B" route intersecting Class "B" route and comprising:
 - (i) ROUTE MARKER CONFIRMATION sign GE12 (or GE13, GE14, or GE15 according to status of the route) located 30 m to 100 m beyond the junction, AND at

regular intervals of 500 m on lower speed (60 km/h) and up to 1 km for higher speed routes (80 km/h);

- (ii) ROUTE MARKER signs GE12.1 and GE12.2 for right and left turns (right mounted above left) located on the far side of the junction in close proximity to the STREET NAME sign GL1, or traffic signal if available;
- (iii) ADVANCE ROUTE MARKER signs GE12.3, GE12.4 and GE12.5 in the position normally occupied by ADVANCE DIRECTION sign GD1; OR

(b) a limited "set" consisting only of items (i) and (ii) from paragraph 9.6.3.1(a).

2 TRAILBLAZER signs GE1 to GE8 are generally only applicable in some extraordinary circumstance. They should be provided in addition to any minimum signing level but can also be used in addition to existing secondary level direction signs. Factors which warrant the use of trailblazer signs are:

- (a) closely spaced parallel routes;
- (b) connections between lower level routes and higher level routes, particularly when a significant traffic generator is located on or near the lesser route;
- (c) if space for larger direction signs is limited.

3 It is recommended that cardinal directions be displayed on all route marker and trailblazer signs. Applications of route marker and trailblazer signs are shown in Figures 9.40 and 9.41.

9.6.4 Applications of Urban Local and Tourist Direction Signs

1 LOCAL DIRECTION and TOURIST DIRECTION signs are supplementary to a standardised system of navigational direction signs. In an urban environment this standardised system will relate to road class and other physical factors according to the space available and the status of the system at a given point in time. Since they are supplementary, LOCAL and TOURIST DIRECTION signs are not provided according to road class in a standard manner. However, when provided, after compliance with warrants, they should normally be located according to standardised rules. For details of the positions of LOCAL and TOURIST DIRECTION signs refer to the following sections of this chapter:

- (a) Section 9.3 for the relevant steps in the preparation of an "Urban Guidance Signing Plan" - Figure 9.16;
- (b) Section 9.4 for full details of the use of LOCAL DIRECTION signs including classification and warrants for their use; for typical applications see Figures 9.23 to 9.26;
- (c) Section 9.5 for full details of the use of TOURIST DIRECTION signs including classification and warrants for their use; for typical applications see Figures 9.33 to 9.36.

2 Figures 9.44 to 9.54 in this section also indicate, where appropriate, the position(s) in which LOCAL and/or TOURIST DIRECTION signs may be placed, when warranted.

- 3 The provision of LOCAL and TOURIST DIRECTION signs in smaller urban areas should not present difficulties, particularly when tourism is a fairly low key activity. As the level of tourist activity grows the pressure on space dictates that signs in both these categories be provided in a planned and controlled manner on an area wide basis. Specific details of how this planning and control may be exercised are covered in Section 9.5 for TOURIST DIRECTION signs, but the provision of LOCAL DIRECTION signs should become an integral part of such an approach. Figures 9.42 and 9.43 illustrate examples of a planned provision of LOCAL and TOURIST DIRECTION signs in an urban area.
- 2 The selection of an appropriate sign size must be related to traffic volumes, road width and operating speed (amongst other criteria - see Subsection 9.3.9). If traffic volumes are such that road markings are commonly covered by a queue of vehicles the intermediate 1600 mm (H) x 1200 mm (W) standard sign size should be specified. This size should also be specified when the roadway has four or more lanes and/or the operating speed is over 70 km/h.
- 3 Diagrammatic signs are commonly specified in a temporary form for urban roadworks. These applications are dealt with in detail in Chapter 13: *Roadworks Signing*.

9.6.5 Applications of the Levels of Urban Guidance Signing

- 1 Figures 9.44 to 9.54 show the 13 levels of urban guidance signing identified in Figure 9.15 and listed in Subsection 9.3.9. The figures illustrate sign sequences and are self-explanatory. Details of individual signface designs and details of design limitations can be found in Volume 1, Chapter 4 and in Volume 4, Chapters 4, 5, 6, and 7.
- 2 Positions are indicated for the possible inclusion of local and tourist destination signs which can be correlated with Figures 9.23 to 9.26 and 9.33 to 9.36 which show typical sign positions for these signs only and with similar figures in Chapter 4 for tourism signs.
- 3 The application of guidance signs is related to the urban street classification (see Section 9.2), but the different levels covered in Figures 9.44 to 9.54 are not directly related to street classes such as Class "B1" and Class "B2", or Class "C1" and Class "C2". In other words the chosen signing level is dependent on other factors as illustrated in Figure 9.15. In effect this means that a Class "B2" route in one part of a metropolitan area may be signed at Level 2B (see Figure 9.50) and a Class "B1" route in another part of the area may be signed in exactly the same way because they exhibit the same range of criteria values.
- 4 In addition to the standard levels of signing illustrated in Figures 9.44 to 9.54 a selection of other situations is covered. These deal with detailed conditions related to specific types of road geometry or traffic control. The type of signing illustrated may be incorporated into any of the layouts given in Figures 9.44 to 9.54 when appropriate.
- 4 The use of Diagrammatic signs is also relatively common in conjunction with specific types of road marking applications such as:
- at lane drop situations;
 - at the beginning or end of dual carriageway roadways;
 - where lanes merge or converge.
- These types of application are covered in Chapter 2: *Road Marking Applications*.
- 5 A new sub-class of Diagrammatic sign has been developed which deals with exclusive turning lane situations which are commonly found in urban areas, particularly in one way streets subject to heavy traffic volumes. A range of typical applications of such signs is included in Chapter 2.
- 6 Figures 9.57 to 9.59 show a selection of typical urban Diagrammatic sign applications and include recommendations on sequential treatment and sign spacing. It is a common practice to provide two or even three diagrammatic signs in a sequence. The first sign, or first and second signs, are displayed with a supplementary plate showing the distance to the point to which the sign applies. The last or final sign in the sequence is mounted as close to this point as possible. It will be common in urban areas that it will only be possible to site an advance sign OR a "final" sign from the desired sequence. In such circumstances the primary objective in choosing the sign position should be to maximise the visibility and therefore effectiveness of the sign.

9.6.6 Applications of Urban Diagrammatic Signs

- 1 The applications of Diagrammatic guidance signs are very similar whether the signs are provided in a rural situation or an urban one. The principal differences are likely to be:
- the size of the signs specified - in urban areas there is commonly insufficient side space to accommodate the larger standard sign sizes - for this reason a special standard urban sign size of 1200 mm (H) x 900 mm (W) is available;
 - the distance between successive signs in a sequence - due to reduced operating speeds signs may be located closer together than is recommended for higher rural operating speeds (see Volume 1, Chapter 4).



140

Sign Area 0,33m²(+74%)



112

Sign Area 0,21m²(+10%)



105

Sign Area 0,19m²

Comparison of Letter Sizes

Detail 9.37.1 - Sign Sizing and Areas

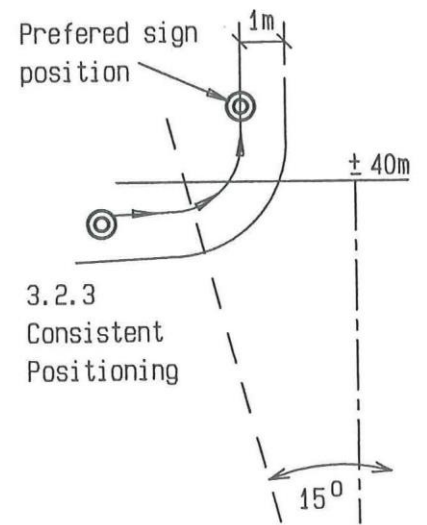
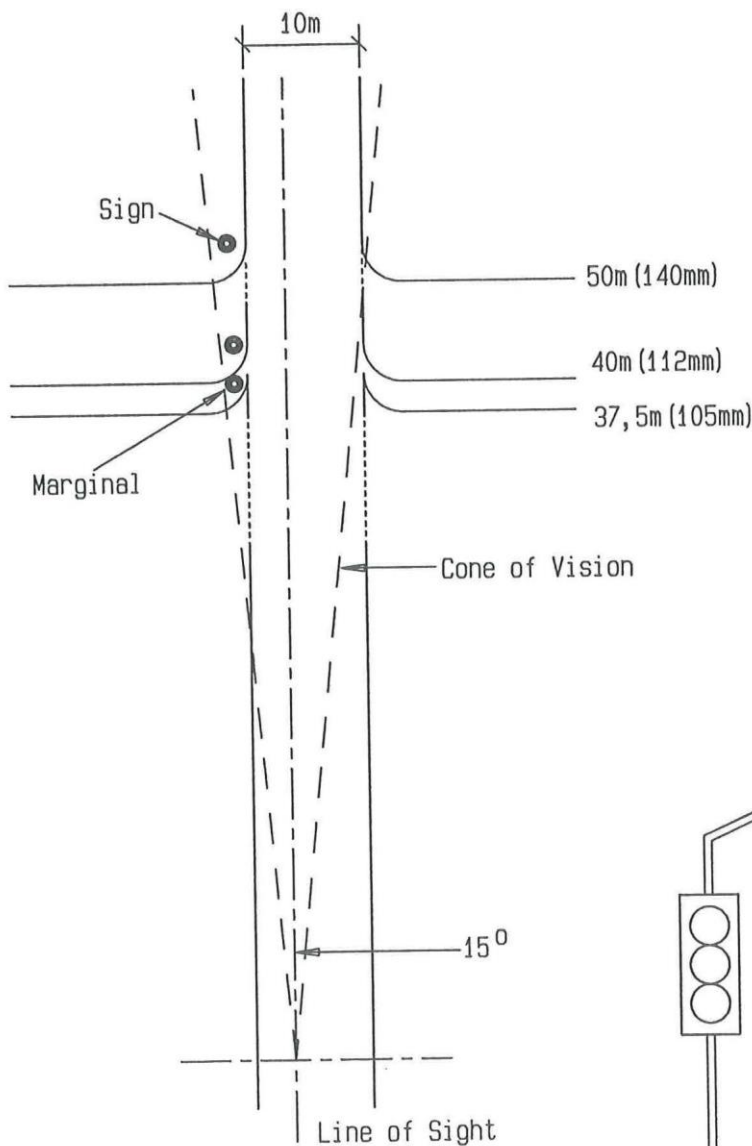

Detail 9.37.3 - Consistent Positioning

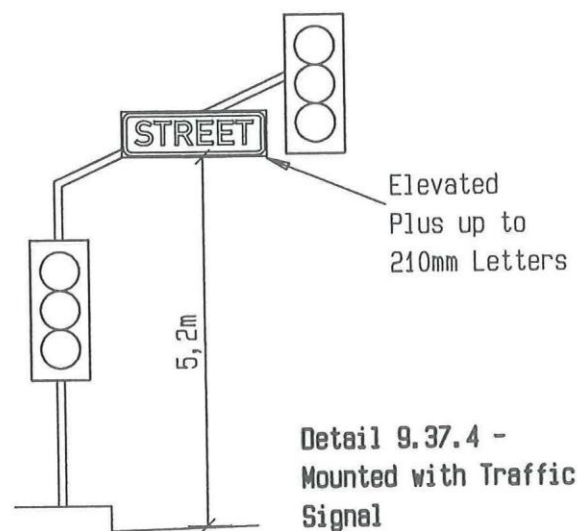

Detail 9.37.4 - Mounted with Traffic Signal

Detail 9.37.2 Cone of Vision

R_c

Fig 9.37

Street Name Signs – Conspicuity/Legibility

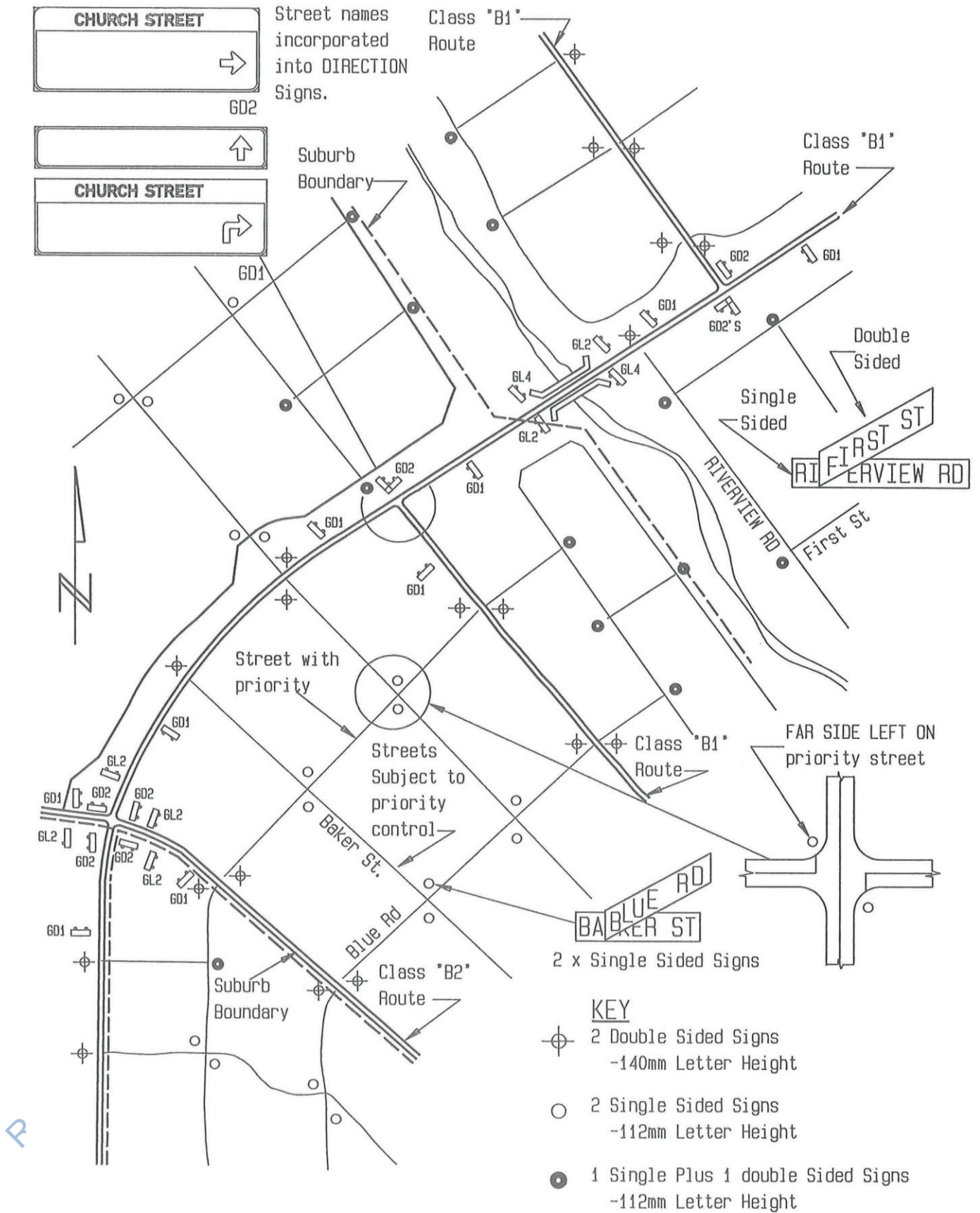
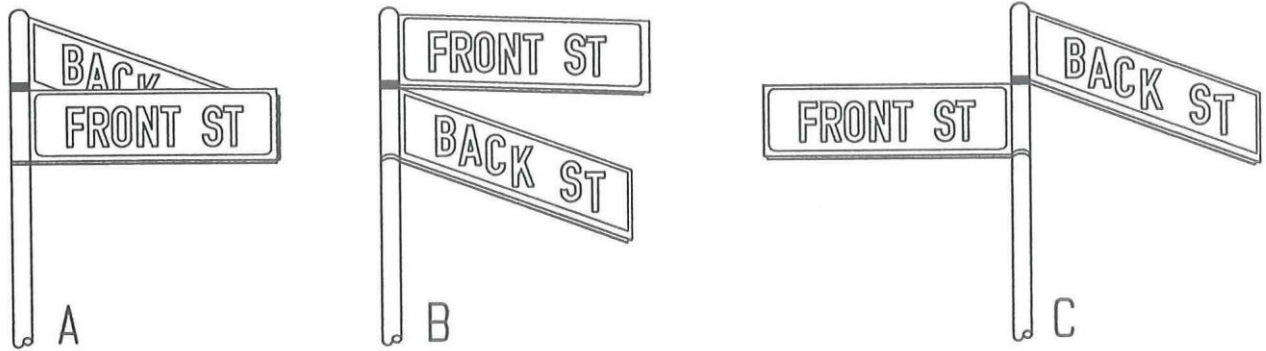

Fig 9.38 Recommended Positioning of Street Name Signs



The positioning and vertical mounting of STREET NAME signs GL1 need to be carefully thought out and co-ordinated. Whilst it is necessary for drivers to be able to read all names, including the name of the street they are in, it is important for good navigation that they can read the name of the intersecting street. One sign must not be allowed to obstruct the view of another, as in A. Detail changes, which may need to vary with site, can be used as in B and C to minimise this effect.

The best solution is subject to:

- method of sign mounting
- mounting height
- sign position in the intersection.

In the wide one-way street example signs at A will be ineffective due to mounting, position and tree cover. Far side mounting at B or C with methods B or C will improve visibility.

STREET NAME signs GL1 are the most numerous in the guidance sign system, and although individually small in area, collectively they represent a significant investment. It is therefore important that they are effective. The examples given are intended to highlight the degree of detail needed to ensure this effectiveness.

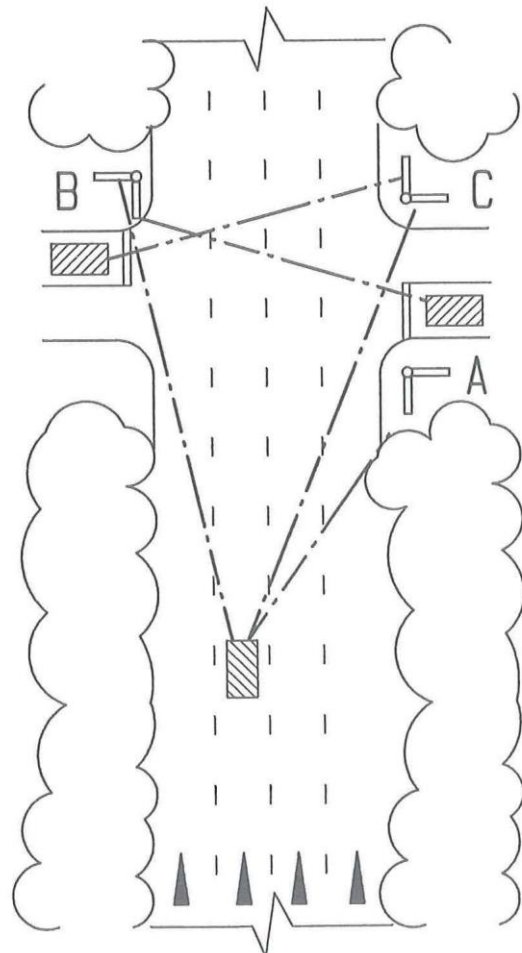

Rc

Fig 9.39

Further Difficulties with the Mounting of GL1 Signs

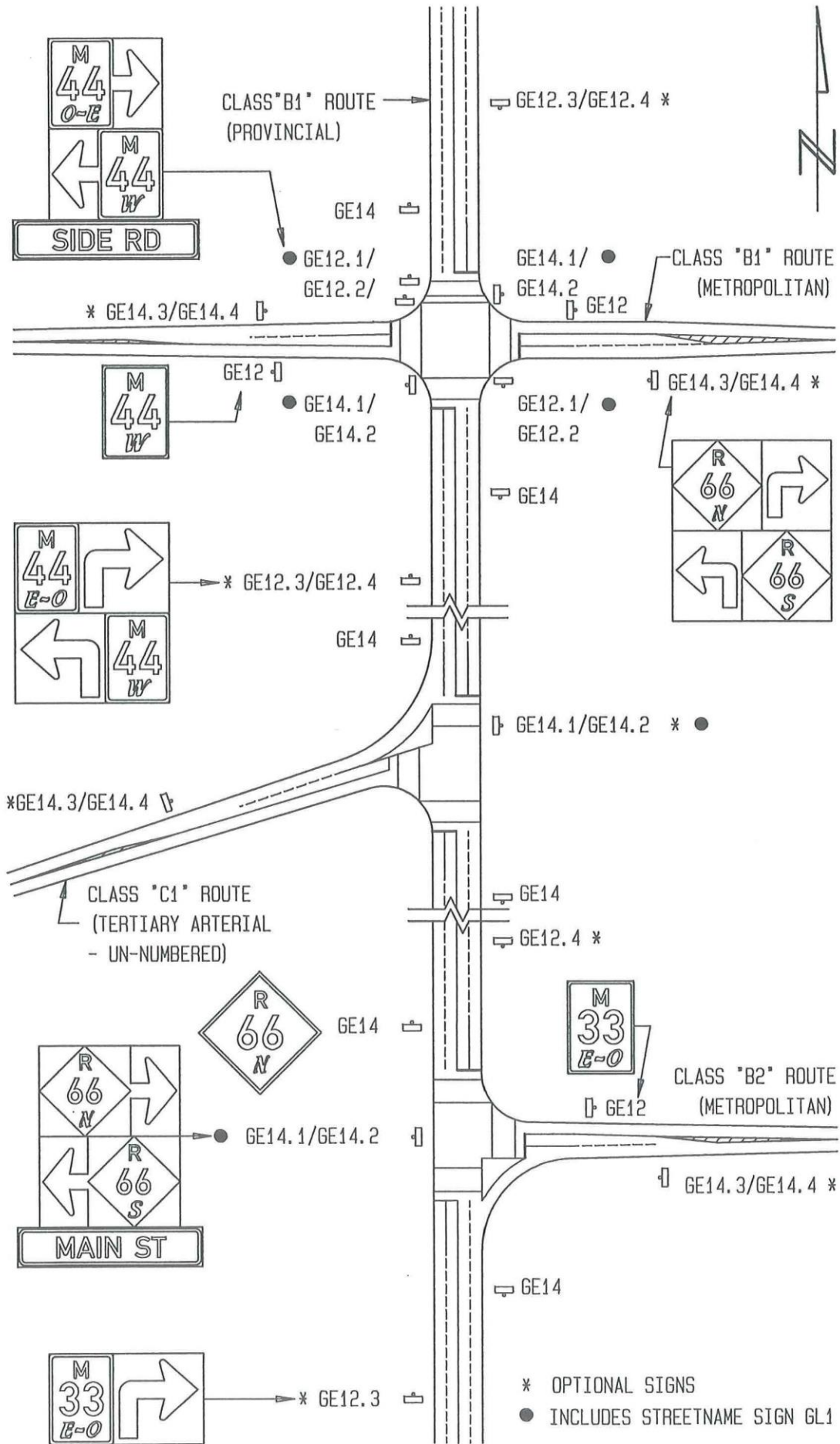

7017

Repr

Fig 9.40

Typical Applications of Route Marker Signs

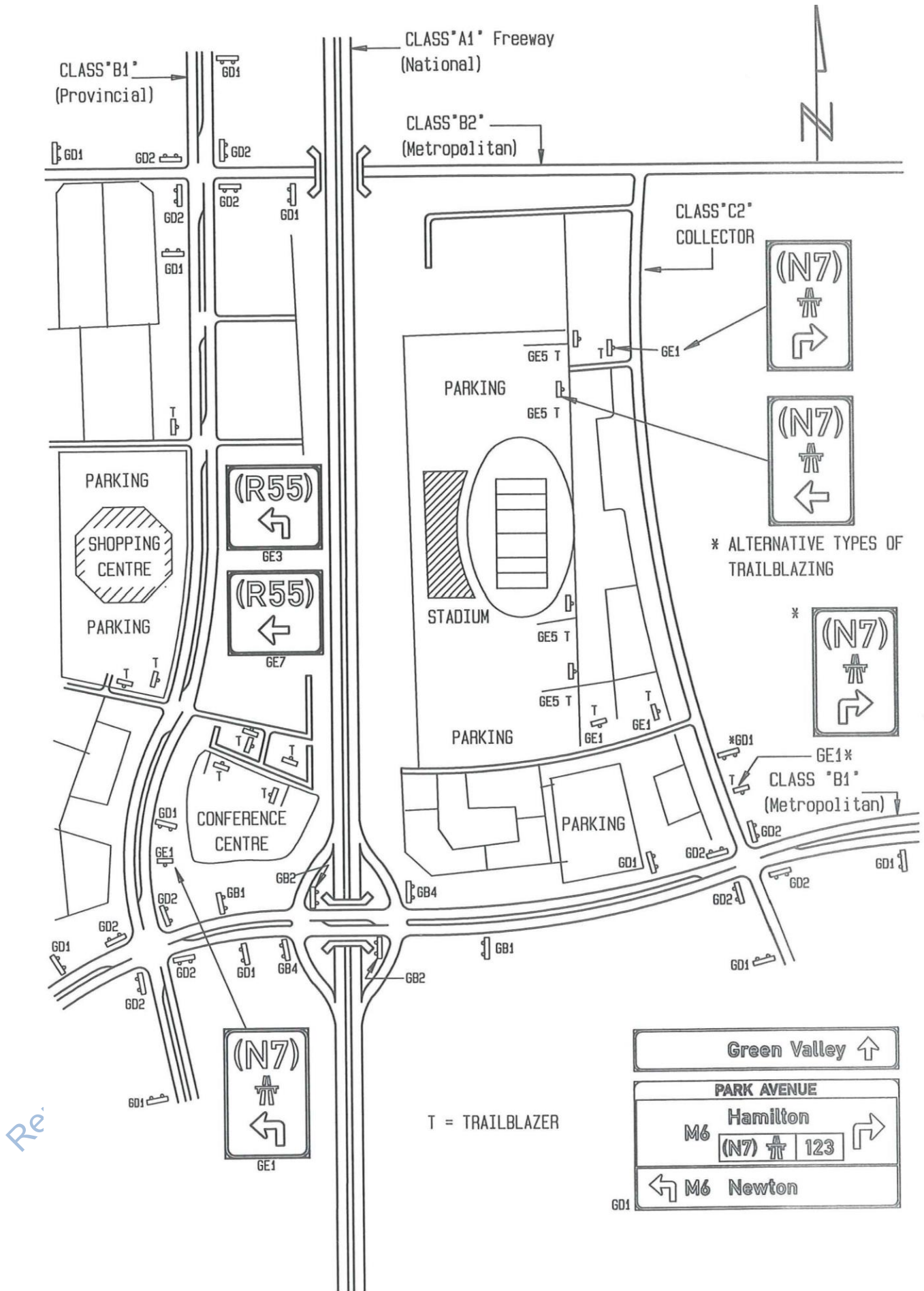
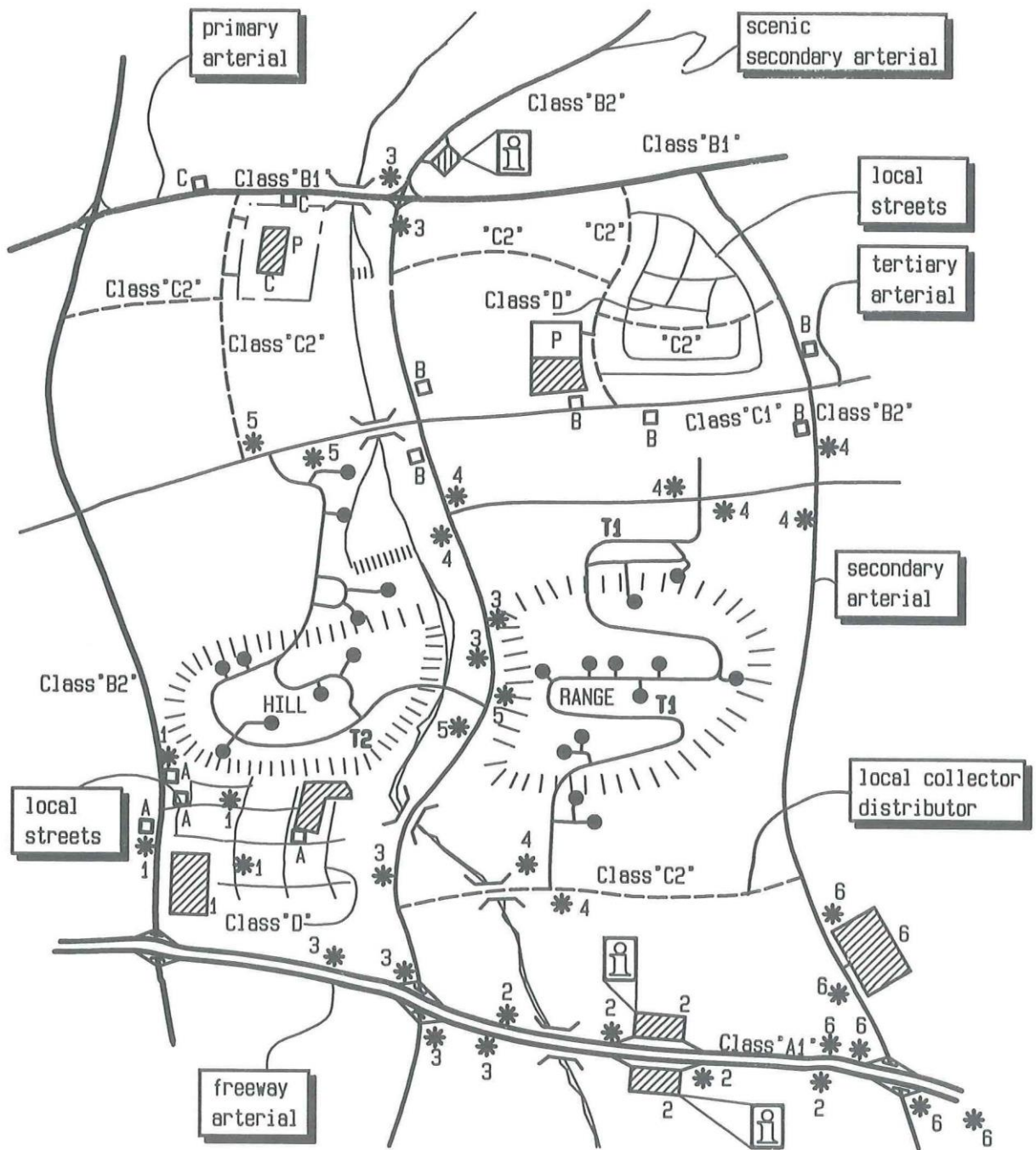



Fig 9.41 Typical Applications of Trailblazer Signs



- TOURIST DIRECTION SIGNS :**
-  Gateway Information Centres
 - *1 Major Hotel
 - *2 Rest & Service Area
 - *3 Scenic Tourist Route (on M route)
 - *4 Tourist Route T1
 - *5 Tourist Route T2
 - *6 Regional Hospital (emergency)

- KEY LOCAL DIRECTION SIGNS :**
-  A Technicon
 -  B Regional Shopping Centre
 -  C Municipal Offices

Repro...

Fig 9.42

Local Direction and Tourist Direction Signing - 1

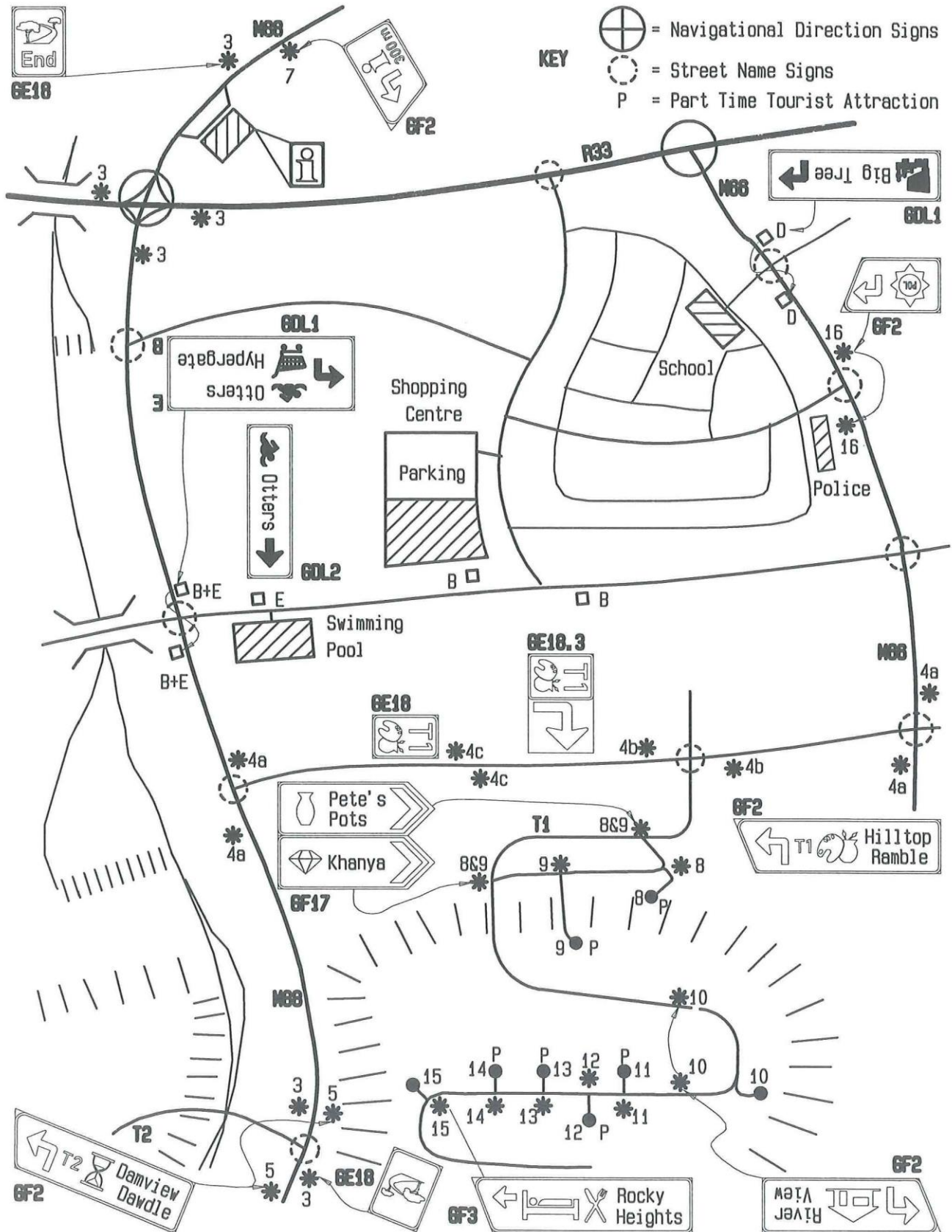

Fig 9.43

Local Direction and Tourist Direction Signing - 2

9.6.7 Urban Signing Level 0A-S Class "A" Systems Interchange Overhead Signs

1 General

By definition a systems interchange is a junction between two freeways. Such freeways will almost certainly be Class "A1" freeways in an urban area. The number of lanes and/or space constraints is likely to warrant the use of overhead signs. The example given in Figure 9.44 depicts overhead signs using the upward pointing arrow system (full details of this system and of downward pointing arrow signs can be found in Volume 1, Chapter 4). The interchange illustrates a range of ramp configurations which are possible at such a junction, including:

- (a) a fully directional ramp (from south to east);
- (b) 360° ramps without a collector-distributor road (on the east/west freeway);
- (c) 360° ramps with a collector-distributor road (from north to west).

Each of these conditions will require different detail treatment in terms of signface design and sign positioning. A full sign sequence is given for the east to west movement which has two exit points, one each for the left and right turn movements respectively. A partial sequence is shown for the south to north movement. The example illustrates the applicability of the upward pointing arrow system to exclusive exit lanes and shared exit and straight-on lanes. In the example the left and right turn destinations can be traced through the sign sequence by following the shading of the destination "boxes".

2 Standard Sign Sequence

The following sign sequence is applicable for a single exit from the freeway as illustrated by the directional ramp (south to west and east) or the C-D road (north to east and west):

- GC1 - PRE ADVANCE EXIT DIRECTION sign
- GC2U - ADVANCE EXIT DIRECTION sign
- GC3U - SUPPLEMENTARY EXIT/THROUGH DIRECTION sign
- GC5U - ADVANCE OFF-RAMP DIRECTION sign
- GC6U - THROUGH DIRECTION sign
- GA4 - GORE EXIT DIRECTION sign
- GC7U - C-D/RAMP EXIT/THROUGH DIRECTION sign
- GA10 - C-D EXIT DIRECTION sign (ground-mounted)
- GA7 - CONFIRMATION sign (ground-mounted).

3 Sign Positions

The positions recommended for the standard signs in the sequence (with the acceptable range of positions given in brackets) are:

- GC1 - 2000 m (2400 m - 1800 m)
- GC2U - 1000 m (1500 m - 900 m)
- GC3U - 500 m (700 m - 300 m)
- GC5U - within 50 m of the exit point
- GC6U - mounted with sign GC5U

- GA4 - with the exit gore
- GC7U - within 50 m of the off ramp split
- GA9 - in the gore of the right turn ramp (360° loop ramps)
- GA7 - 750 m beyond the end of the on-ramp (500 m - 1000 m).

4 Optional Signs

The following optional signs may be used either on the approach to, or exit from, a systems interchange:

- GA8 - EXIT SEQUENCE sign to indicate closely spaced interchanges in an urban area (a systems interchange may be indicated when appropriate by the route number and FREEWAY symbol GDS-4) - located between 3000 m and 2000 m from an exit point;
- GF8 - SERVICE EXIT SEQUENCE sign to indicate available primary tourism services at the nearest point (emergency and fuel), - located 1000 m to 2000 m beyond the end of an on-ramp.

Other options exist for modification of the standard sign sequence according to ramp configuration as follows:

- GC4U - EXIT DIRECTION sign - replaces sign GC5U when the exit serves one direction only (normally the left turn) - a second GC3U sign indicating the second exit will commonly be displayed on the same structure as sign GC4U (see example) - located within 100 m of the exit point.

Other combinations of signs GC4U, GC5U, GC6U and GC7U may be used.

Certain additional signs may be required if one or both of the intersecting freeways is a toll route. For further information see Chapter 6: *Toll Route Signing*.

NOTE: No other form of tourism sign other than sign type GF8 is appropriate within the approaches to a systems interchange. Local destination signs shall not be provided on Class "A" roads.

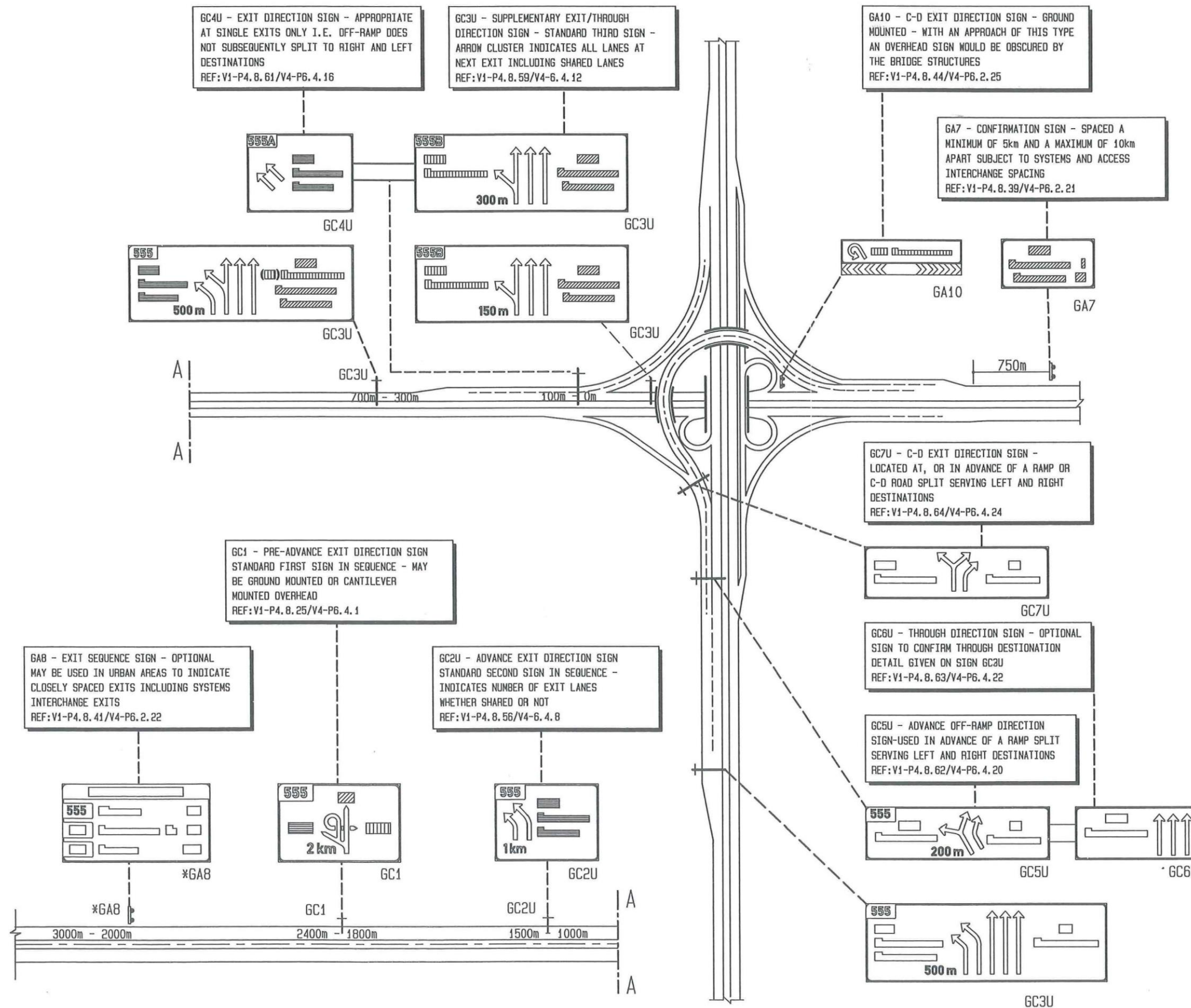

9.6.8 Notes on Figure 9.44

Numbers of Signs Required per Approach

Quantity	Type	Typical Area (m ²)
1	GC1	25
1	GC2U	12
1	GC3U	38
1	GC5U	32
1	GC6U	25
1	GA4	5
1	GC7U	26
1	GA10	8
	GA7	5

The areas given should be considered as guidelines for general estimating only. They are based on the following very general parameters:

- overhead signs d = 60 mm (letter size 420 mm/300 mm)
- ground-mounted signs d = 50 mm (letter size 350 mm/250 mm)
- longest place name = 10 letters
- 4 lines of text on freeway including route number and distance
- 3 lines of text on ramps.

Checklist

One or more of the following factors or questions may require the re-evaluation of the standard signing sequence listed above:

- ramp exit - one direction or both?
- provision of collector-distributor road
- directional ramp - position of additional structures
- position of main structures - overbridge or under-bridge approach?
- provision of additional lanes - particularly between closely spaced interchanges
- unusual junction or ramp alignment (affects arrow alignment on signs)
- lane drop, weave or merge situations may require diagrammatic signs
- does the interchange lead into a by-pass situation?

Fig. 9.44
Urban Signing Level 0A-S
Class "A" Systems Interchange
Overhead Signs

9.6.9 Urban Signing Level 0A-A Class "A" Access Interchange Overhead Signs

1 General

An access interchange is where a freeway system and the rest of an urban street network interface or connect with each other. The connecting street will commonly be a Class "B" numbered route. The number of lanes on the freeway and/or space constraints is likely to warrant the use of overhead signs. The example given in Figure 9.45 depicts overhead signs using the upward pointing arrow system supplemented where appropriate by ground-mounted signs (full details of the upward and downward pointing arrow systems can be found in Volume 1, Chapter 4). Figure 9.46 shows a typical ground-mounted guidance sign sequence for an urban access interchange. Basic factors which may singly or collectively warrant the use of overhead direction signs are (for more detail see Volume 1, Chapter 4, Subsection 4.1.9):

- carriageways with three or more lanes on an approach - this should include intersecting crossroads;
- all freeways with traffic volumes regularly exceeding 50 000 vehicles/day;
- all systems interchanges;
- high percentages of large vehicles;
- when insufficient space is available to correctly position ground-mounted signs;
- to overcome competition from outdoor advertisements.

The upward pointing arrow cluster will vary in configuration with the number of lanes which exit the freeway and with the number of lanes which continue through the interchange. The example illustrates a shared exit and through lane.

2 Standard Sign Sequence

The following is the basic sign sequence which extends to the end of the off ramp and which will commonly be supplemented by optional signs (see below):

- GC2U - ADVANCE EXIT DIRECTION sign
- GC3U - SUPPLEMENTARY EXIT/THROUGH DIRECTION sign
- GC4U - EXIT DIRECTION sign
- GA4 - GORE EXIT DIRECTION sign
- GA6 - OFF-RAMP TERMINAL DIRECTION sign.

3 Sign Positions

The positions recommended for the standard signs in the sequence (with the acceptable range of positions given in brackets) are:

- GC2U - 1000 m (1500 m - 900 m)
- GC3U - 500 m (700 m - 300 m)
- GA4 - within the exit gore
- GA6 - at the ramp terminal - normally on the far side of the cross street.

4 Optional Signs

The following optional signs may be used to supplement the basic sign sequence (see above):

- GF8 - SERVICE EXIT SEQUENCE sign to indicate available primary service at the nearest point beyond a systems interchange - should be located 1000 m to 2000 m beyond the end of an adjacent systems interchange on-ramp but should be no closer than 300 m to any other sign.
- GA8 - EXIT SEQUENCE sign to indicate closely spaced interchanges in an urban area - this should indicate the next two or three interchanges and if there are several closely spaced interchanges (under 5 km spacing) sign GA8 should be used in a "roll-over" manner where one interchange is dropped from the sign and the "new" second or third interchange is added - use of the sign GA8 may remove the need for CONFIRMATION sign GA7 or TOWN NAME sign GL3 on urban freeway by-passes - located between 3000 m and 1500 m from the exit point subject to the provision of other optional signs.
- GC1 - PRE ADVANCE EXIT DIRECTION sign to give early guidance of an exit ahead - appropriate on multi-lane freeways with high traffic volumes and adequate interchange spacing - may not be appropriate if GA8 signs are used.
- GF1 - FREEWAY ADVANCE EXIT (Tourist) sign to give supplementary direction for tourist facilities, service or recreational, **although such applications are limited on freeways, and particularly in urban areas due to the nearest numbered route warrant (see paragraph 9.5.10.3)** - located between 800 m and 600 m from the exit point.
- GA5 - ADVANCE OFF-RAMP TERMINAL DIRECTION sign to give advance guidance to left and right-turn (orientation) destinations - in an urban signing environment these destinations are introduced only on the GA5 or GA6 signs - sign GA5 is appropriate for multi-lane off-ramps but may be replaced by an overhead sign - located 250 m to 200 m from the ramp terminal.
- GF2 - ADVANCE TURN (Tourism) sign to continue a message previously displayed on a GF1 sign (new destination information shall not be introduced by means of sign GF2) - the sign may comprise a left stack or a right stack, or both stacks - if space is limited sign GF2 may be combined with sign GDL1 subject to the signface rules given in Volumes 1 and 4 - located 180 m to 140 m from the ramp terminal.
- GA7 - CONFIRMATION sign to indicate distances to control or familiar destinations on the freeway route - in an urban environment sign GA7 should be provided on a systematic basis at strategic interchanges - located 750 m beyond the end of the on-ramp (range 250 m - 1000 m).

For details of additional signs or variations in signface detail for toll routes see Chapter 6: *Toll Route Signing*.

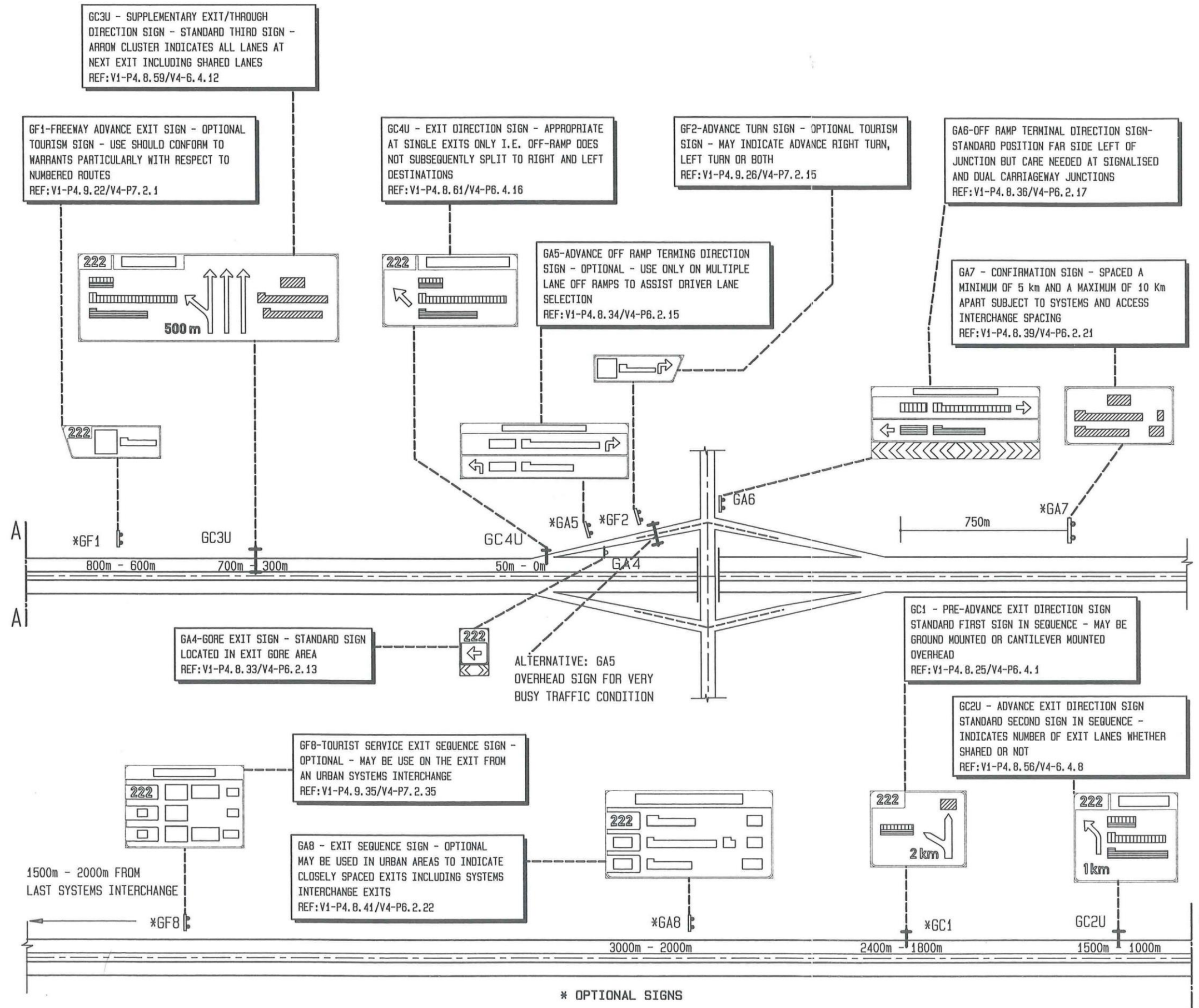

9.6.10 Notes on Figure 9.45

Numbers of Signs Required for Freeway Approach

Quantity	Type	Typical Area (m ²)
1	GC2U	25
1	GC3U	30
1	GC4U	20
1	GA4	5
1	GA6	7

The areas given should be considered as guidelines for general estimating only. They are based on the following very general parameters:

- overhead signs d = 60mm (letter size 420mm/300mm)
- ground-mounted signs d = 30mm (letter size 210mm/150mm)
- longest place name = 10 letters
- 3 lines of text for sign GC2U
- 2 lines of text for signs GC34 and GC4U
- single orientation destinations (sign GA6).

Checklist

One or more of the following factors or questions may require the re-evaluation of the standard signing sequence listed above:

- heavy traffic volumes (with significant percentages of heavy vehicles or other slow moving traffic)
- position of other structures not specifically related to the interchange
- horizontal and vertical alignment on the freeway and ramps
- provision of additional lanes - particularly between closely spaced interchanges
- unusual ramp configurations
- lane drop, merge or weave situations may require diagrammatic signs
- steep cut or fill conditions making ground-mounted signs difficult to locate
- signs too closely spaced for readability or for total message transfer - in particular optional signs GF1 and GF2
- the availability of direct access rest and service areas, either within an interchange or between access interchanges

Fig. 9.45 Urban Signing Level 0A-A Class "A" Access Interchange Overhead Signs

9.6.11 Urban Signing Level 1A-A Class "A" Access Interchange Ground-Mounted Signs

1 General

An access interchange is where a freeway system and the rest of an urban street network interface or connect with each other. The connecting street will commonly be a Class "B" numbered route. Ground-mounted signs will normally be specified for two lane sections of freeway. The example given in Figure 9.46 depicts standard ground-mounted freeway signs supplemented by optional guidance signs (see paragraph 9.6.9.1 for details of warrants for overhead signs).

2 Standard Sign Sequence

The following is the basic sign sequence which extends to the end of the off-ramp and which will commonly be supplemented by optional signs (see below):

- GA2 - ADVANCE EXIT DIRECTION sign
- GA3 - EXIT DIRECTION sign
- GA4 - GORE EXIT DIRECTION sign
- GA6 - OFF-RAMP TERMINAL DIRECTION sign.

3 Sign Positions

The positions recommended for the standard signs in the sequence (with the acceptable range of positions given in brackets) are:

- GA2 - 1000 m (1300 m - 900 m)
- GA3 - within 50 m of the exit point
- GA4 - within the exit gore
- GA6 - at the ramp terminal - normally on the far side of the cross street.

4 Optional Signs

The following optional signs may be used to supplement the basic sign sequence (see above):

- GF8 - SERVICE EXIT SEQUENCE sign to indicate available primary service at the nearest point beyond a systems interchange - should be located 1000 m to 2000 m beyond the end of an adjacent systems interchange on-ramp but should be no closer than 300 m to any other sign.
- GA8 - EXIT SEQUENCE sign to indicate closely spaced interchanges in an urban area - this should indicate the next two or three interchanges and if there are several closely spaced interchanges (under 5 km spacing) sign GA8 should be used in a "roll-over" manner where one interchange is dropped from the sign and the "new" second or third interchange is added - use of the sign GA8 may remove the need for CONFIRMATION sign GA7 or TOWN NAME sign GL3 on urban freeway by-passes - located between 3000 m and 1500 m from the exit point subject to the provision of other optional signs.
- GC1 - PRE ADVANCE EXIT DIRECTION sign to give early guidance of an exit ahead - appropriate on multi-lane freeways with high traffic volumes and adequate interchange spacing - may not be appropriate if GA8 signs are used.

- GA 2/3 - SUPPLEMENTARY EXIT DIRECTION sign to give supplementary guidance when road alignment, vertical or horizontal, or both, makes sight distance to the exit point and sign GA3 difficult - locate at 700 m - 400 m.
- GF1 - FREEWAY ADVANCE EXIT (Tourist) sign to give supplementary direction for tourist facilities, service or recreational, **although such applications are limited on freeways, and particularly in urban areas due to the nearest numbered route warrant (see paragraph 9.5.10.3)** - located between 800 m and 600 m from the exit point.
- GA5 - ADVANCE OFF-RAMP TERMINAL DIRECTION sign to give advance guidance to left and right-turn (orientation) destinations - in an urban signing environment these destinations are introduced only on the GA5 or GA6 signs - sign GA5 is appropriate for multi-lane off-ramps but may be replaced by an overhead sign - located 250 m to 200 m from the ramp terminal.
- GF2 - ADVANCE TURN (Tourist) sign to continue a message previously displayed on a GF1 sign (new destination information shall not be introduced by means of sign GF2) - the sign may comprise a left stack or a right stack, or both stacks - if space is limited sign GF2 may be combined with sign GDL1 subject to the signface rules given in Volumes 1 and 4 - located 180 m to 140 m from the ramp terminal.
- GA7 - CONFIRMATION sign to indicate distances to control or familiar destinations on the freeway route - in an urban environment sign GA7 should be provided on a systematic basis at strategic interchanges - located 750 m beyond the end of the on-ramp (range 250 m - 1000 m).
- GF9 - REST AND SERVICE SEQUENCE sign to indicate the availability of Class III rest and service facilities accessible from the freeway and the distance between successive facilities - sign GF9 may become relevant on urban freeways as the provision of high standard rest and service areas develops (see Chapter 4 for further details).

For details of additional signs or variations in signface detail for toll routes see Chapter 6: *Toll Route Signing*.

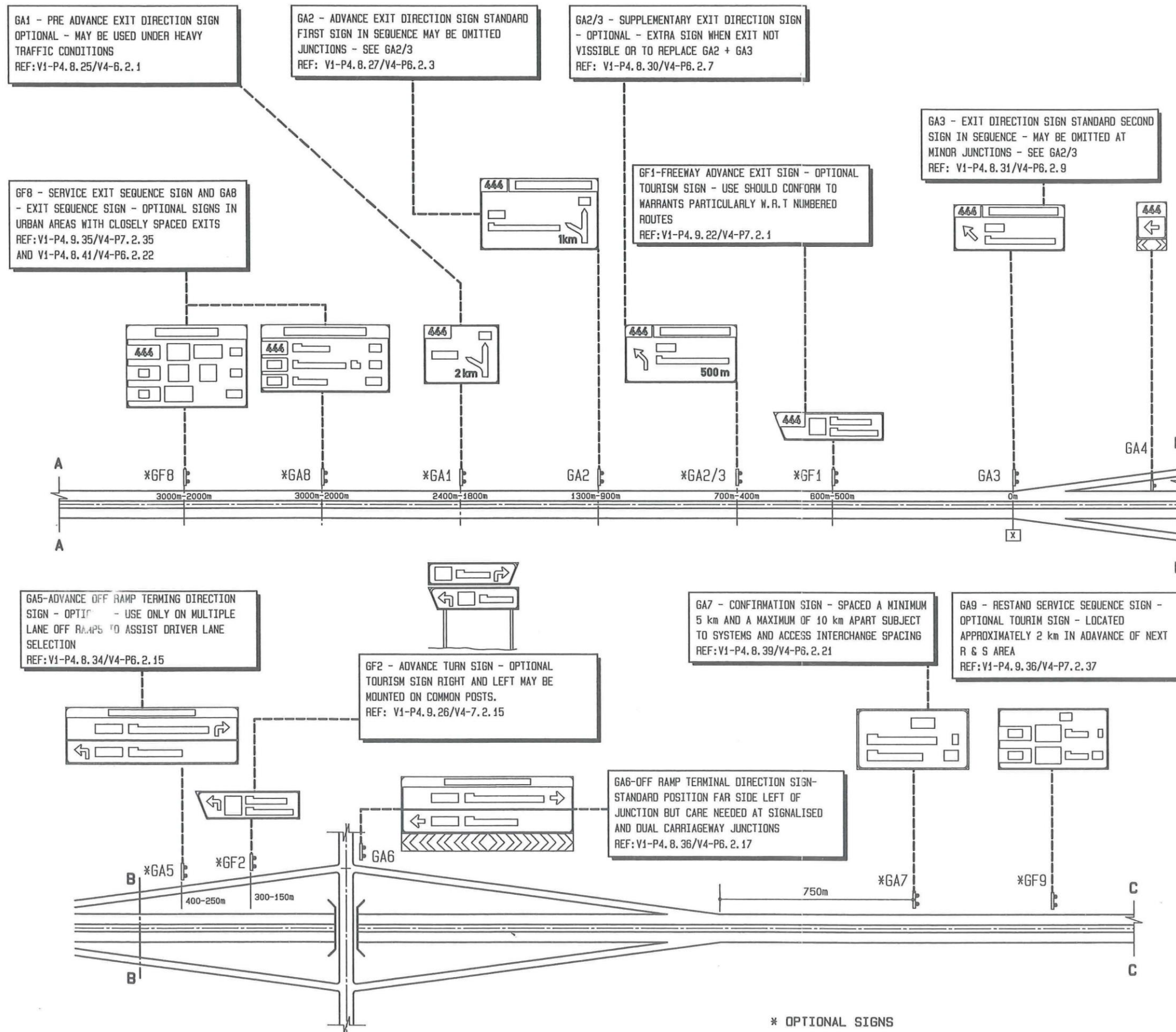

9.6.12 Notes on Figure 9.46

Numbers of Signs Required for Freeway Approach		
Quantity	Type	Typical Area (m ²)
1	GA2	16
1	GA3	10
1	GA4	5
1	GA6	7

The areas given should be considered as guidelines for general estimating only. They are based on the following very general parameters:

- d = 50 mm (letter size 350 mm/250 mm) for signs GA2 and GA3
- d = 30 mm (letter size 210 mm/150 mm) for sign GA6
- longest place name = 10 letters
- 2 lines of text
- single orientation destinations (sign GA6).

Checklist

One or more of the following factors or questions may require the re-evaluation of the standard signing sequence listed above:

- more than three lanes on the freeway
- position of other structures not specifically related to the interchange
- horizontal and vertical alignment on the freeway and ramps
- the provision of additional lanes - particularly between closely spaced interchanges
- unusual ramp configuration
- lane drop, merge or weave situations may require diagrammatic signs
- steep cut or fill conditions making ground-mounted signs difficult to locate
- signs too closely spaced for readability or for total message transfer - in particular optional signs GF1 and GF2
- the availability of direct access rest and service facilities, either within an interchange or between access interchanges

Fig. 9.46
Urban Signing Level 1A-A
Class "A" Access Interchange
Ground Mounted Signs

9.6.13 Urban Signing Level 1A-C Freeway Class "A" – Crossroad Preferred Level

1 General

Crossroad signing on the approach to an access interchange provides the "other side" of the urban street network interface with a freeway system. The signs used in Figure 9.47 are typical of any Class "B" preferred level of guidance signing (see Figure 9.49) but exhibit a number of significant differences. The signs have a mixed colour code to "trailblaze" the freeway and are detailed separately in Volumes 1 and 4. **It should be noted that if the freeway is a Class "A2" facility, blue background signs are not used on the freeway, and therefore the use of the blue colour coding on the crossroad signs shall fall away.** It is a general rule that direction sign stacks directing drivers onto the freeway shall display only one destination name. This destination name is normally the route terminal familiar destination, or, if the distance to this destination is considerable (e.g. Cape Town from Johannesburg) some other equally familiar intermediate destination (e.g. Bloemfontein).

Tourist direction and local direction signs shall not be used to direct drivers onto a freeway.

2 Standard Sign Sequence

The following is the basic sign sequence which should be provided on an intersecting cross street on the approach to a freeway access interchange, irrespective of the class of intersecting street (freeways excluded):

- GB1 - CROSS-ROAD ADVANCE DIRECTION sign
- GB2 - NEAR-SIDE ON-RAMP DIRECTION sign
- GB3 - FAR-SIDE ON-RAMP ADVANCE DIRECTION sign
- GB4 - FAR-SIDE ON-RAMP DIRECTION sign.

3 Sign Positions

The positions recommended for certain signs in the standard signs sequence vary according to the speed limit (or preferably the operating speed) on the intersecting street. Positions are given below for 60 km/h and 80 km/h. Positions for other approach speeds may be interpolated from the values given or they may be obtained by consulting Figure 4.43 in Volume 1, Chapter 4:

- GB1 - 150 m to 180 m (80 km/h) - 100 m (60 km/h)
- GB2 - on the far side of the on-ramp for diamond interchanges, or opposite the turn onto the on-ramp for parclo-interchanges
- GB3 - between the left and right turn on-ramps and before the main bridge structure (see "Optional Signs" below)
- GB4 - opposite the right turn on-ramp for diamond interchanges, or on the far side of the on-ramp for parclo-interchanges.

4 Optional Signs

The following are the only optional signs which should be considered for display in addition to the standard sign sequence, unless the freeway is a toll route, and they represent alternatives for each other:

- GD3 - CONFIRMATION sign indicating the cross street route number and the distance to one or more control or familiar destinations - use of sign GD3 is not commonly warranted in urban areas but may be appropriate outward-bound from the urban area or inward-bound to indicate the distance to the town or city centre - located 60 m to 100 m beyond the interchange far-side ramps
- GE12 - ROUTE MARKER CONFIRMATION (METROPOLITAN) sign indicating the number and class of the intersecting route when this is a numbered route (other variations include GE13 (REGIONAL), GE14 (PROVINCIAL) and GE15 (NATIONAL)) - located 60 m to 100 m beyond the far-side ramps.

A further option exists in that sign GB4 may be varied to include a straight-on destination stack above the freeway on-ramp indication. This variation of sign GB4 and sign GD3 should not normally be used together.

Space limitations may make it necessary to omit sign GB3. If the sign is omitted consideration should be given to increasing the letter size used on sign GB4 to increase its legibility distance.

For details of additional signs or variations in signface detail for toll routes see Chapter 6: *Toll Route Signing*.

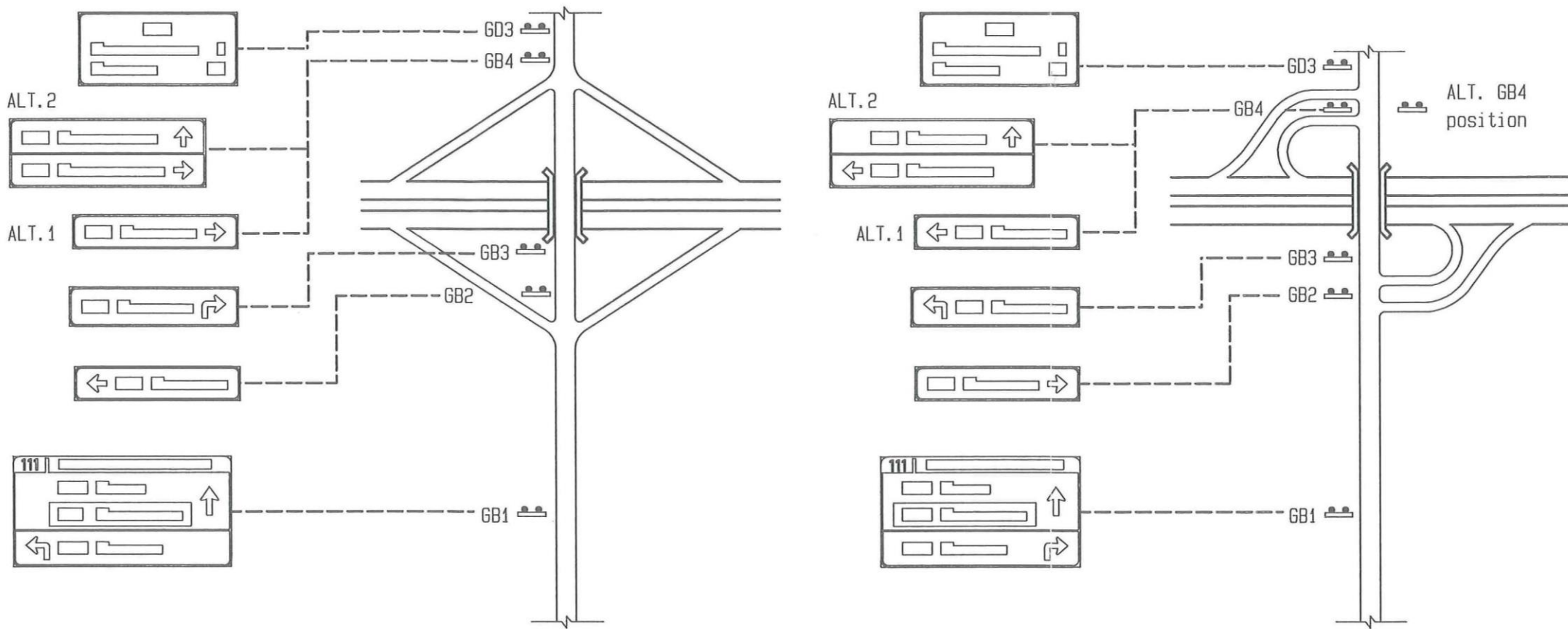

9.6.14 Notes on Figure 9.47

Numbers of Signs Required per Approach

Quantity	Type	Typical Area (m ²)
1	GB1	12 ₈₀ 7 ₆₀
1	GB2	4 ₈₀ 2,25 ₆₀
1	GB3	4 ₈₀ 2,25 ₆₀
1	GB4	4 ₈₀ 2,25 ₆₀

The areas given should be considered as guidelines for general estimating only. They are based on the following very general parameters:

- d = 40 mm (letter size 280 mm/200 mm) - 80 km/h (see suffix "80")
- d = 30 mm (letter size 210 mm/150 mm) - 60 km/h (see suffix "60")
- one destination per direction
- longest place name = 10 letters.

Checklist

One or more of the following factors or questions may require the re-evaluation of the standard signing sequence listed above:

- more than four lanes on the cross-street (consider overhead signs)
- non-standard ramp configurations
- dual-carriageway cross street
- ramp terminal junction geometry (particularly the provision of channelizing islands)
- high fills or steep cuts which limit sign locating options (see Figure 9.48)
- limited longitudinal space to accommodate signs.

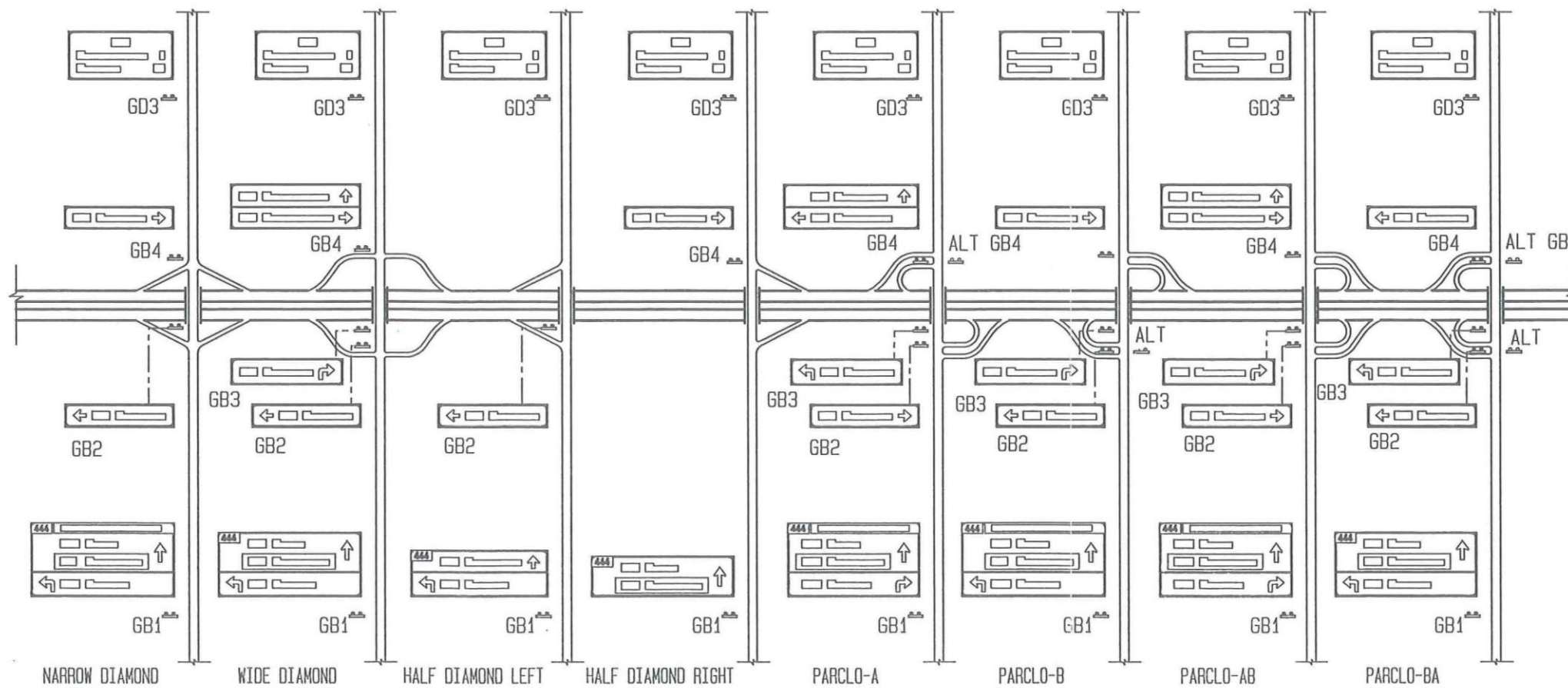

Fig. 9.47
Urban Signing Level 1A-C
Freeway Class "A" Crossroad
Preferred Level

9.6.15 Urban Signing Level 2A – C Freeway Class "A" – Crossroad Minimum level

1 General

The signing illustrated in this example should only be considered when access interchange crossroad approaches offer very limited space for direction signs. Such situations will most commonly occur when the freeway is located within a central business district environment.

The orientational guidance given by the signs illustrated is obtained solely from the cardinal directions displayed i.e. north, south, east or west. The use of a vertically formatted map-type sign as an advance sign allows the ramp configuration to be clearly indicated for diamond and parclo-interchanges and the sign shape should commonly be able to be accommodated spanning the sidewalk with sufficient clearance for pedestrians to walk under the sign.

Tourist direction and local direction signs shall not be used to direct drivers onto a freeway.

2 Standard Sign Sequence

The following the basic sign sequence is the minimum level of signing which should be provided on an intersecting cross street, on the approach to an access interchange, in an urban environment:

- GD7 - MAP-TYPE DIRECTION sign (variation of a STAGGERED JUNCTION map)
- GE15.2 - DIRECTION ROUTE MARKER (NATIONAL) sign (other variations include GE14.2 (PROVINCIAL), GE13.2 (REGIONAL) and GE12.2 (METROPOLITAN)) - left turn
- GE15.1 - DIRECTION ROUTE MARKER (NATIONAL) sign (variations as for sign GE15.2) - right turn.

3 Sign Positions

Positions given below refer to 60 km/h approach speeds:

- GD7 - 60 m to 100 m
- GE15.2 - on the far side of the on-ramp for diamond interchanges, or opposite the turn onto the on-ramp for parclo-interchanges
- GE15.1 - opposite the right turn on-ramp for diamond interchanges, or on the far side of the on-ramp for parclo-interchanges.

4 Optional Signs

The following is the only optional sign which may be considered for display in addition to the minimum level sign sequence, unless the freeway is a toll route (see Chapter 6):

- GE12 - ROUTE MARKER CONFIRMATION (METROPOLITAN) sign indicating the number and class of the intersecting route when this is a numbered route (other variations include GE13 (REGIONAL), GE14 (PROVINCIAL) and GE15 (NATIONAL) - located 60 m to 100 m beyond the far-side ramps.

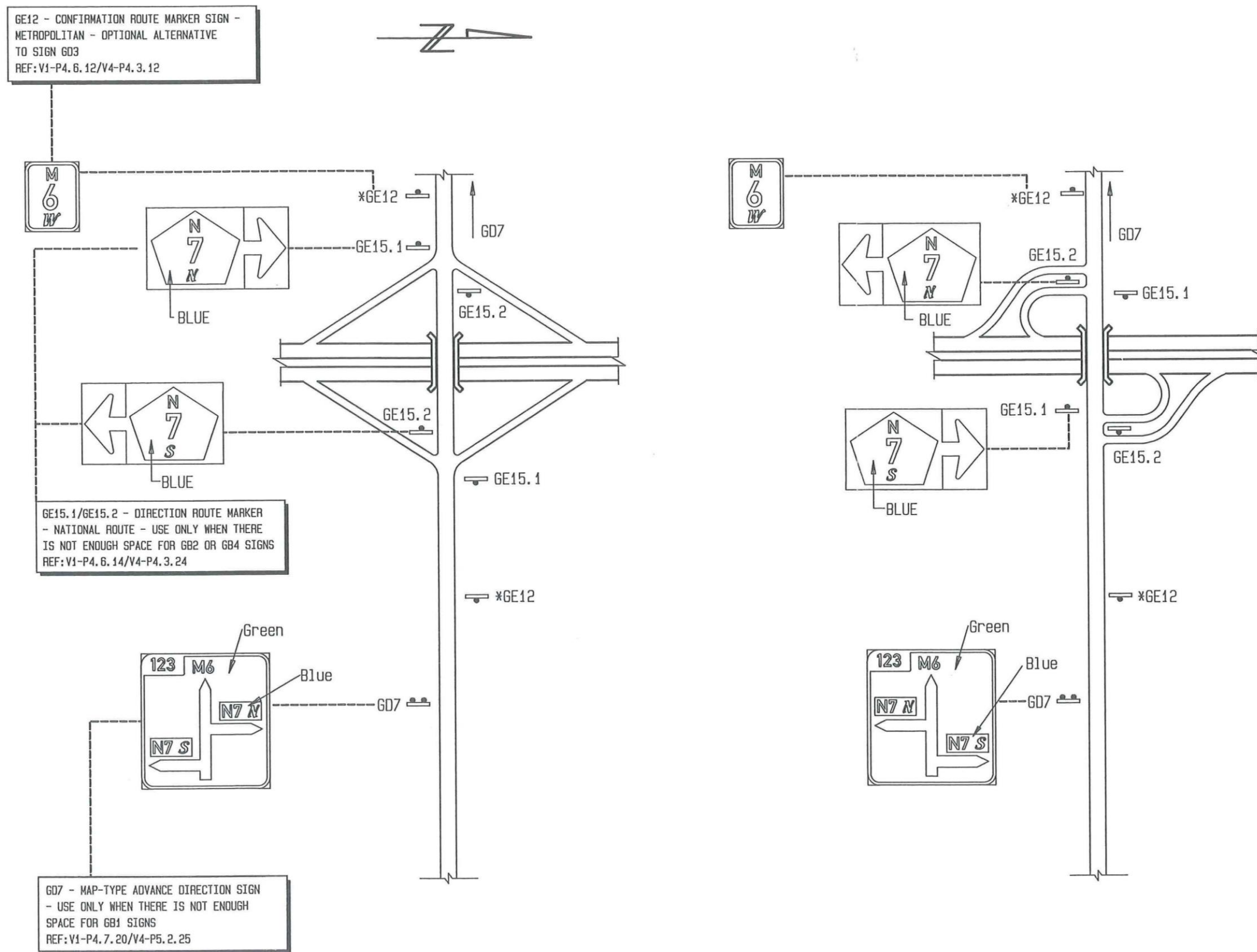

9.6.16 Notes on Figure 9.48

Numbers of Signs Required per Approach

Quantity	Type	Typical Area (m ²)
1	GD7	5
1	GE15.2	0,6
1	GE15.1	0,6

The areas given are based on the following general parameters:

- d = 30 mm for GD7
- signs GE15.2 and GE15.1 are a fixed size although it is optional to increase these sizes by a factor of 4 over 3 (see Volume 4, Chapter 4).

Checklist

One or more of the following factors or questions may require the re-evaluation of the standard signing sequence listed above:

- more than four lanes on the cross street (consider overhead signs)
- non-standard ramp configurations
- adequate space to accommodate the standard sign sequence illustrated in Figure 9.47.

Fig. 9.48
Urban Signing Level 2A-C
Freeway Class "A" Crossroad
Minimum Level

9.6.17 Urban Signing Level 1B Class "B" Junctions Preferred Level

1 General

Class "B" urban roads are numbered routes and can be sub-classified into Class "B1" Primary Arterial and Class "B2" Secondary Arterial routes. The preferred level of guidance signing illustrated in Figure 9.49 may be applied to both Class "B1" and Class "B2" routes because the decision on signing level is related to a range of physical characteristics of the route concerned. These parameters are covered in Section 9.4 and a decision flow chart is given in Figure 9.15. The ultimate factor in deciding on Class "B" route guidance signing is likely to be affordability. Class "B" junctions must be signed at least to the minimum level illustrated in Figure 9.52. The signing level of Class "B" junctions is thus independent of the sub-class of a given approach to a junction. **Therefore, if a Class "B1" and a Class "B2" route intersect the signing levels on the different approaches may all be the same, or each may be different according to the physical characteristics of the approaches** (the four levels of signing available are covered in Figures 9.49 to 9.52.) **However, it is very important that message continuity be maintained along specific routes. It is not recommended that the signing level be altered frequently through successive junctions on a route.** If orientational destinations have been used at a particular junction these should continue to be displayed along a route until the destination is reached. **The decision to display destination names should therefore not be taken in isolation but with a full knowledge of the ability to provide a common level of signing at subsequent junctions.**

Signing levels appropriate to junctions between Class "C" and Class "D" streets and Class "B" routes are covered by Figures 9.53 and 9.54.

In Figure 9.49 all signs which might be provided on approaches to a typical cross road or T-junction between Class "B" routes are indicated on the plan. A representative selection only of the signface layouts of typical signs is illustrated. **The names of the intersecting streets are incorporated into the direction signs at this level of signing. It is therefore not necessary to provide separate STREET NAME signs GL1. If the street name changes at a junction the manner of display of the street names on the direction signs is different.** Examples of both are illustrated.

Figures 9.49 to 9.52 do not include SUBURB NAME sign GL2 or TOWN or CITY NAME sign GL3. Examples are given in Figure 9.14.

2 Standard Sign Sequence

The following is the basic sign sequence which comprises the Preferred Level of Class "B" route direction signing:

- GD1 - STACK-TYPE ADVANCE DIRECTION sign
- GD2 - STACK-TYPE DIRECTION sign.

3 Sign Positions

The position of sign GD1 should be related to the speed limit or preferably the operating speed. Positions are given for 80 km/h

and 60 km/h. Positions for other approach speeds may be obtained from Figure 4.43 in Volume 1, Chapter 4.

The position of sign GD1 should always precede the start of an exclusive right and/or left turn lane:

- GD1 - 150 m to 180 m (80 km/h) - 100 m (60 km/h)
- GD2 - in the far side left corner of the junction (this may be varied for roadways with sliproads or dual carriageways - see Figure 9.56).

4 Optional Signs

The following optional signs may be used to supplement the basic sign sequence (see above), **subject to compliance with warrants and design criteria relating to the total amount of information, letter sizes, spacing between signs in a sequence and the reading time available (where practical signs GF2 and GDL1 should be displayed as a composite sign):**

- GE12 - ROUTE MARKER CONFIRMATION (METROPOLITAN) sign indicating the number and class of the intersecting route (other variations include GE13 (REGIONAL), GE14 (PROVINCIAL) and GE15 (NATIONAL) - located 60 m to 100 m beyond the junction.
- GDL1 - ADVANCE LOCAL DIRECTION sign - **subject to compliance with warrants this sign may be introduced on a class "B" route** (see Section 9.4), - the sign may comprise a left stack or a right stack, or both stacks (see GF2 above) - located 50 m to 60 m (80 km/h) or 40 m (60 km/h) in advance of the junction.
- GF2 - ADVANCE TURN (Tourist) sign - **subject to compliance with warrants this sign may be introduced on a class "B" route** or it may continue a message previously displayed on a freeway (or another numbered route subject to the relaxation of the nearest numbered route rule **see Section 9.5 and Chapter 4**), - the sign may comprise a left stack or a right stack, or both stacks - sign GF2 may be combined with sign GDL1 either by providing a single composite sign or by mounting the signs on common supports, subject to the signface rules given in Volumes 1 and 4 - and located 100 m to 120 m (80 km/h) or 70 m (60 km/h) in advance of the junction.
- GL2 - SUBURB NAME sign - to indicate passage from one suburb to another along a numbered route - its role should be considered as secondary to the other signs listed above particularly with regard to allocation of position - preferably located on the exit from a junction within 30 m to 60 m of the suburb boundary.
- GL3 - TOWN NAME sign - to indicate entry into a specific town or city - it should be located so as not to conflict with other guidance signs (accurate location at the town boundary should be considered secondary to avoiding conflict with other signs).

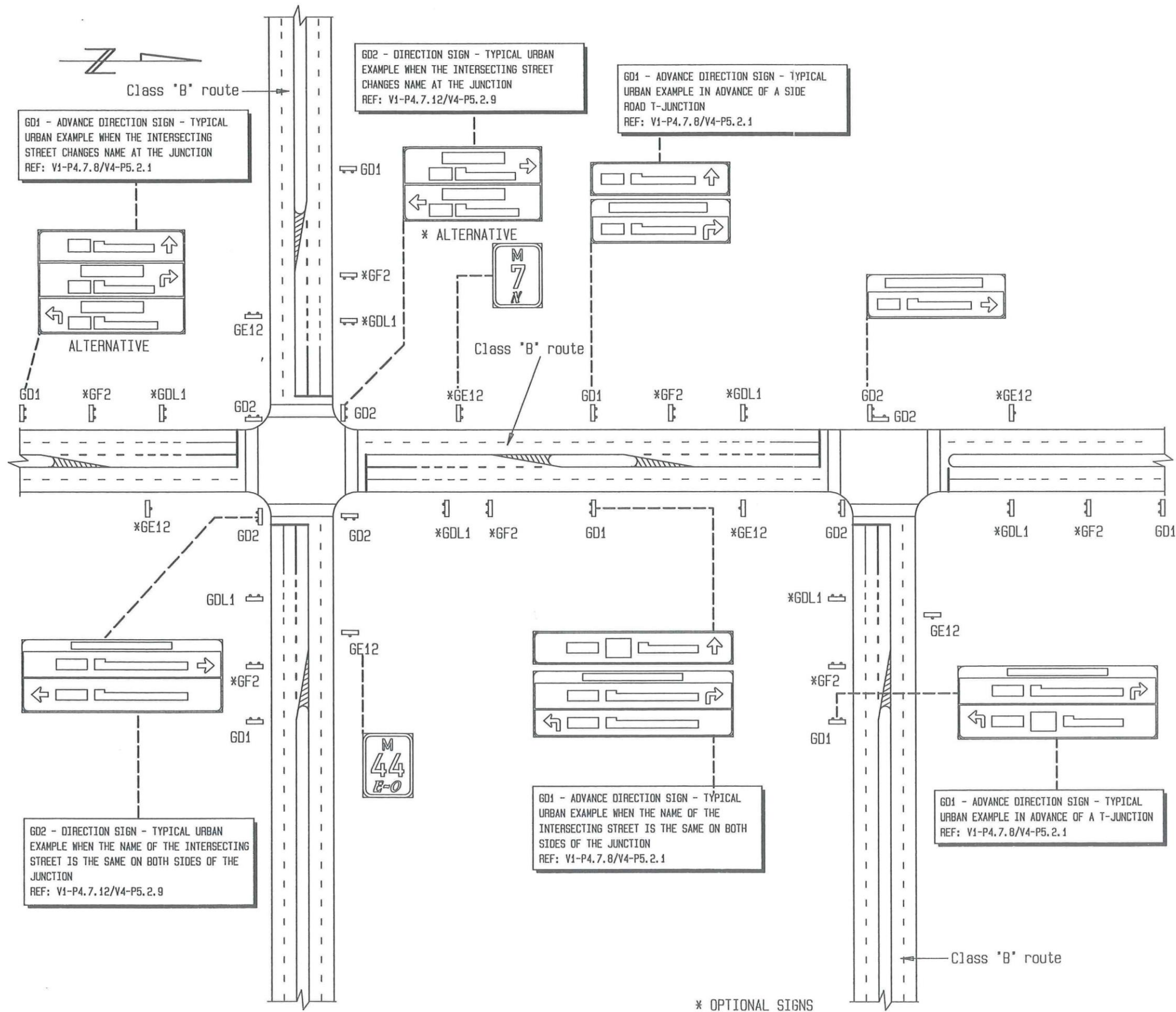

9.6.18 Notes on Figure 9.49

Numbers of Signs Required per Approach

Quantity	Type	Typical Area (m ²)
for a single street name		
1	GD1	15 ₈₀ 8,5 ₆₀
1	GD2	8 ₈₀ 4,75 ₆₀
for two street names		
1	GD1	18 ₈₀ 10 ₆₀
1	GD2	11 ₈₀ 6 ₆₀

The areas given should be considered as guidelines for general estimating only. They are based on the following very general parameters:

- d = 40 mm (letter size 280 mm/200 mm) for 80 km/h (see suffix "80")
- d = 30 mm (letter size 210 mm/150 mm) for 60 km/h (see suffix "60")
- longest place name = 10 letters
- single orientation destinations in all stacks
- signface design to full justification of arrows, route numbers and destinations.

Checklist

One or more of the following factors or questions may require the re-evaluation of the signs provided at an urban junction between two Class "B" routes:

- is sign message continuity being maintained?
- is there adequate space for direction signs displaying the intended destination names at a correct letter size to ensure legibility?
- are existing GD1 and/or GD2 signs in place?
- is a relaxation of the nearest numbered route warrant justified for the display of GF2 and/or GDL1 signs?
- is there sufficient space to accommodate additional GF2 and/or GDL1 signs if warranted?
- is there sufficient reading time to allow for the addition of GF2 and/or GDL1 signs if warranted?
- can a combination GF2/GDL1 sign be used?
- should the whole sign sequence be revised?
- is there conflict with other street furniture?
- is there competition from advertising signs?

Fig. 9.49
Urban Signing Level 1B
Class "B" Junctions
Preferred Level

9.6.19 Urban Signing Level 2B Class "B" Junctions Intermediate Level 1

1 General

The Intermediate Level 1 of guidance signing for Class "B" routes is the second highest level of signing and **is dependent on there being sufficient space within the junction to locate GD2 signs**. Intermediate Level 1 guidance signing illustrated in Figure 9.50 may be applied to both Class "B1" and Class "B2" routes because the decision on signing level is related to a range of physical characteristics of the route concerned. These parameters are covered in Section 9.3 and a decision flow chart is given in Figure 9.15. **If a Class "B1" and a Class "B2" route intersect the signing levels on the different approaches may all be the same, or each may be different according to the physical characteristics of the approaches** (a total of four levels of signing are available and are covered in Figures 9.49 to 9.52). **It is very important that message continuity be maintained along specific routes. It is not recommended that signing levels be altered frequently through successive junctions on a route. Class "B" junctions must be signed at least to the Minimum Level illustrated in Figure 9.52** (see Subsection 9.6.23).

In Figure 9.50 all standard signs and optional signs which might be provided on approaches to a typical cross road and a typical T-junction between Class "B" routes are indicated on the plan of the junctions. A representative selection only of the signface layouts of typical signs is illustrated. It should be noted that the street names of the intersecting streets are incorporated into the direction signs at this level of signing. It is therefore not necessary to provide separate STREET NAME signs GL1. **It should also be noted that if the street name changes through the junction the manner of display of the street names on the direction signs is different.** See Figure 9.49 for examples of both types of display.

Figures 9.49 to 9.52 do not include SUBURB NAME sign GL2 or TOWN or CITY NAME sign GL3. Examples are given in Figure 9.14.

2 Standard Sign Sequence

The following is the basic sign sequence which comprises the Intermediate Level 1 of Class "B" route direction signing:

- GE12.3 - (over GE12.4) ADVANCE DIRECTION ROUTE MARKER (METROPOLITAN) signs (mounted RIGHT over LEFT) (other variations include GE13.3/GE13.4 (REGIONAL), GE14.3/GE14.4 (PROVINCIAL) or GE15.3/GE15.4 (NATIONAL) - on the through leg of a T-junction only one sign is required)
- GD2 - STACK-TYPE DIRECTION sign.

3 Sign Positions

The position of signs GE12.3/GE12.4 should be determined in terms of the speed limit (or preferably the operating speed) on the approach. Positions are given below for 80 km/h and 60 km/h. Positions for other approach speeds may be interpolated from the values given or they may be obtained from Figure 4.43 in Volume 1, Chapter 4.

The position of signs GE12.3/GE12.4 should preferably precede the start of an exclusive right and/or left turn lane.

- GE12.3 - (and GE12.4) 150 m to 180 m (80 km/h) - 100 m (60 km/h)
- GD2 - in the far side left corner of the junction (this may be varied for roadways with slip roads or dual carriageways - see Figure 9.56).

4 Optional Signs

The following optional signs may be used to supplement the basic sign sequence (see above) provided adequate longitudinal space is available between signs in a sequence:

- GE12 - ROUTE MARKER CONFIRMATION (METROPOLITAN) sign indicating the number and class of the intersecting route (other variations include GE13 (REGIONAL), GE14 (PROVINCIAL) and GE15 (NATIONAL) - located 60 m to 100 m beyond the junction.
- GDL1 - ADVANCE LOCAL DIRECTION sign - **subject to compliance with warrants this sign may be introduced on a class "B" route** (see Section 9.4), - the sign may comprise a left stack or a right stack, or both stacks (see GF2 above) - located 50 m to 60 m (80 km/h) or 40 m (60 km/h) in advance of the junction.
- GF2 - ADVANCE TURN (Tourist) sign - **subject to compliance with warrants this sign may be introduced on a class "B" route** or it may continue a message previously displayed on a freeway (or another numbered route subject to the relaxation of the nearest numbered route rule **see Section 9.5 and Chapter 4**), - the sign may comprise a left stack or a right stack, or both stacks - sign GF2 may be combined with sign GDL1 either by providing a single composite sign or by mounting the signs on common supports, subject to the signface rules given in Volumes 1 and 4 - and located 100 m to 120 m (80 km/h) or 70 m (60 km/h) in advance of the junction.
- GL2 - SUBURB NAME sign - to indicate passage from one suburb to another along a numbered route - its role should be considered as secondary to the other standard and optional signs listed above particularly with regard to allocation of position - preferably located on the exit from a junction within 30 m to 60 m of the suburb boundary.
- GL3 - TOWN NAME sign - to indicate entry into a specific town or city - it should be located so as not to conflict with other guidance sign (accurate location at the town boundary should be considered secondary to avoiding conflict with other signs).

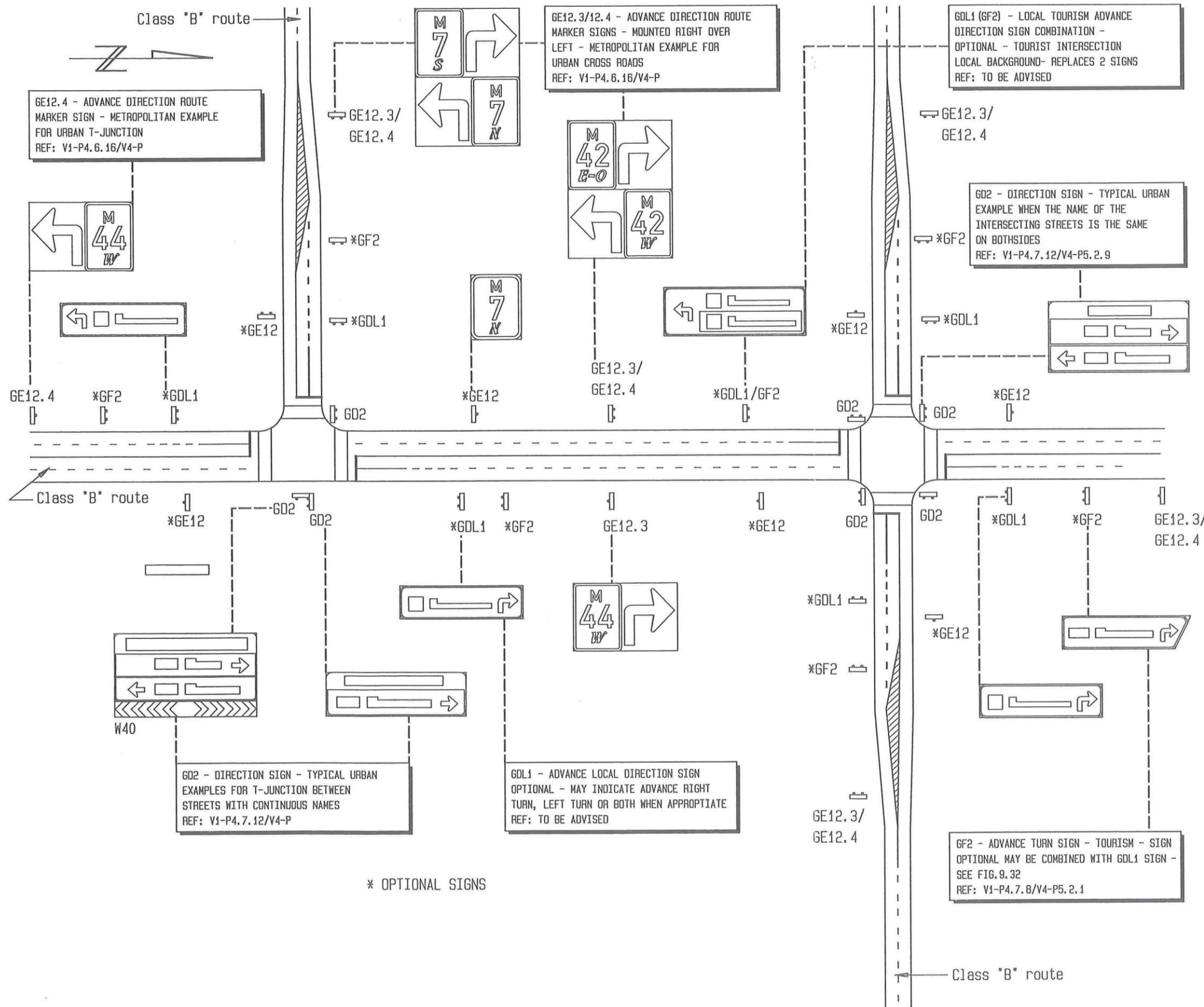

9.6.20 Notes on Figure 9.50

Numbers of Signs Required per Approach

Quantity	Type	Typical Area (m ²)
for a single street name		
1	GE12*	1-1.4 _(by route type)
1	GD2	8 ₈₀ 4,75 ₆₀
for two street names		
1	GE12*	1-1.4 _(by route type)
1	GD2	11 ₈₀ 6 ₆₀

NOTE: * Optional signs

- The areas given are based on the following parameters:
- d = 40 mm (letter size 280 mm/200 mm) for 80 km/h (see suffix "80")
 - d = 30 mm (letter size 210 mm/150 mm) for 60 km/h (see suffix "60")
 - longest place name = 10 letters
 - single orientation destinations in all stacks
 - signface design to full justification of arrows, route numbers and destinations.

Checklist

One or more of the following factors or questions may require the re-evaluation of the signs provided at an urban junction between two Class "B" routes:

- is sign message continuity being maintained?
- is there space within the junction for GD2 signs?
- is a relaxation of the nearest numbered route warrant justified for the display of GF2 and/or GDL1 signs?
- is there sufficient space to accommodate additional GF2 and/or GDL1 signs if warranted?
- can a combination GF2/GDL1 sign be used?
- is there competition from advertising signs?

Fig. 9.50
Urban Signing Level 2B
Class "B" Junctions
Intermediate Level 1

9.6.21 Urban Signing Level 3B Class "B" Junctions Intermediate Level 2

1 General

The Intermediate Level 2 of guidance signing for Class "B" routes is the second lowest level of signing and **is dependent on there being sufficient space within the approach side space to locate GD1 signs**. Intermediate Level 2 guidance signing illustrated in Figure 9.51 may be applied to both Class "B1" and Class "B2" routes because the decision on signing level is related to a range of physical characteristics of the route concerned. These parameters are covered in Section 9.3 and a decision flow chart is given in Figure 9.15. If a Class "B1" and a Class "B2" route intersect the signing levels on the different approaches may all be the same, or each may be different according to the physical characteristics of the approaches (a total of four levels of signing are available and are covered in Figures 9.49 to 9.52). It is very important that message continuity be maintained along specific routes. It is not recommended that signing levels be altered frequently through successive junctions on a route. Class "B" junctions must be signed at least to the Minimum Level illustrated in Figure 9.52 (see Subsection 9.6.23).

In Figure 9.51 all standard signs and optional signs which might be provided on approaches to a typical cross road and a typical T-junction between Class "B" routes are indicated on the plan of the junctions. A representative selection only of the signface layouts of typical signs is illustrated. It should be noted that the street names of the intersecting streets are incorporated into the advance direction signs at this level of signing. It should also be noted that if the street name changes through the junction the manner of display of the street names on the advance direction signs is different (see Figure 9.49 for examples of both type of display). Separate STREET NAME signs GL1 are provided at the junction.

Figures 9.49 to 9.52 do not include SUBURB NAME sign GL2 or TOWN or CITY NAME sign GL3. Examples are given in Figure 9.14.

2 Standard Sign Sequence

The following is the basic sign sequence which comprises the Intermediate Level 2 of Class "B" route direction signing:

- GD1 - STACK-TYPE ADVANCE DIRECTION sign
- GE12.1 - (over GE12.2) DIRECTION ROUTE MARKER (METROPOLITAN) signs (mounted RIGHT over LEFT) (other variations include GE13.1/GE13.2 (REGIONAL), GE14.1/GE14.2 (PROVINCIAL) or GE15.1/GE15.2 (NATIONAL) - on the through leg of a T-junction only one sign is required)
- GL1 - STREET NAME sign.

3 Sign Positions

The position of sign GD1 should be determined in terms of the speed limit (or preferably the operating speed) on the approach. Positions are given below for 80 km/h and 60 km/h. Positions for other approach speeds may be interpolated from the values given or they may be obtained from Figure 4.43 in Volume 1, Chapter 4.

The position of sign GD1 should preferably precede the start of an exclusive right or left turn lane:

- GD1 - 150 m to 180 m (80 km/h) - 100 m (60 km/h)
- GE12.1 - (and GE12.2 and GL1) in the far left corner of the junction.

4 Optional Signs

The following optional signs may be used to supplement the basic sign sequence (see above) provided adequate longitudinal space is available between signs in a sequence:

- GE12 - ROUTE MARKER CONFIRMATION (METROPOLITAN) sign indicating the number and class of the intersecting route (other variations include GE13 (REGIONAL), GE14 (PROVINCIAL) and GE15 (NATIONAL) - located 60 m to 100 m beyond the junction.
- GDL1 - ADVANCE LOCAL DIRECTION sign - **subject to compliance with warrants this sign may be introduced on a class "B" route** (see Section 9.4), - the sign may comprise a left stack or a right stack, or both stacks (see GF2 above) - located 50 m to 60 m (80 km/h) or 40 m (60 km/h) in advance of the junction.
- GF2 - ADVANCE TURN (Tourist) sign - **subject to compliance with warrants this sign may be introduced on a class "B" route** or it may continue a message previously displayed on a freeway (or another numbered route subject to the relaxation of the nearest numbered route rule **see Section 9.5 and Chapter 4**), - the sign may comprise a left stack or a right stack, or both stacks - sign GF2 may be combined with sign GDL1 either by providing a single composite sign or by mounting the signs on common supports, subject to the signface rules given in Volumes 1 and 4 - and located 100 m to 120 m (80 km/h) or 70 m (60 km/h) in advance of the junction.
- GL2 - SUBURB NAME sign - to indicate passage from one suburb to another along a numbered route - its role should be considered as secondary to the other standard and optional signs listed above particularly with regard to allocation of position -preferably located on the exit from a junction within 30 m to 60 m of the suburb boundary.
- GL3 - TOWN NAME sign - to indicate entry into a specific town or city - it should be located so as not to conflict with other guidance signs (accurate location at the town boundary should be considered secondary to avoiding conflict with other signs).

Reproduced under Government Printers Authorization

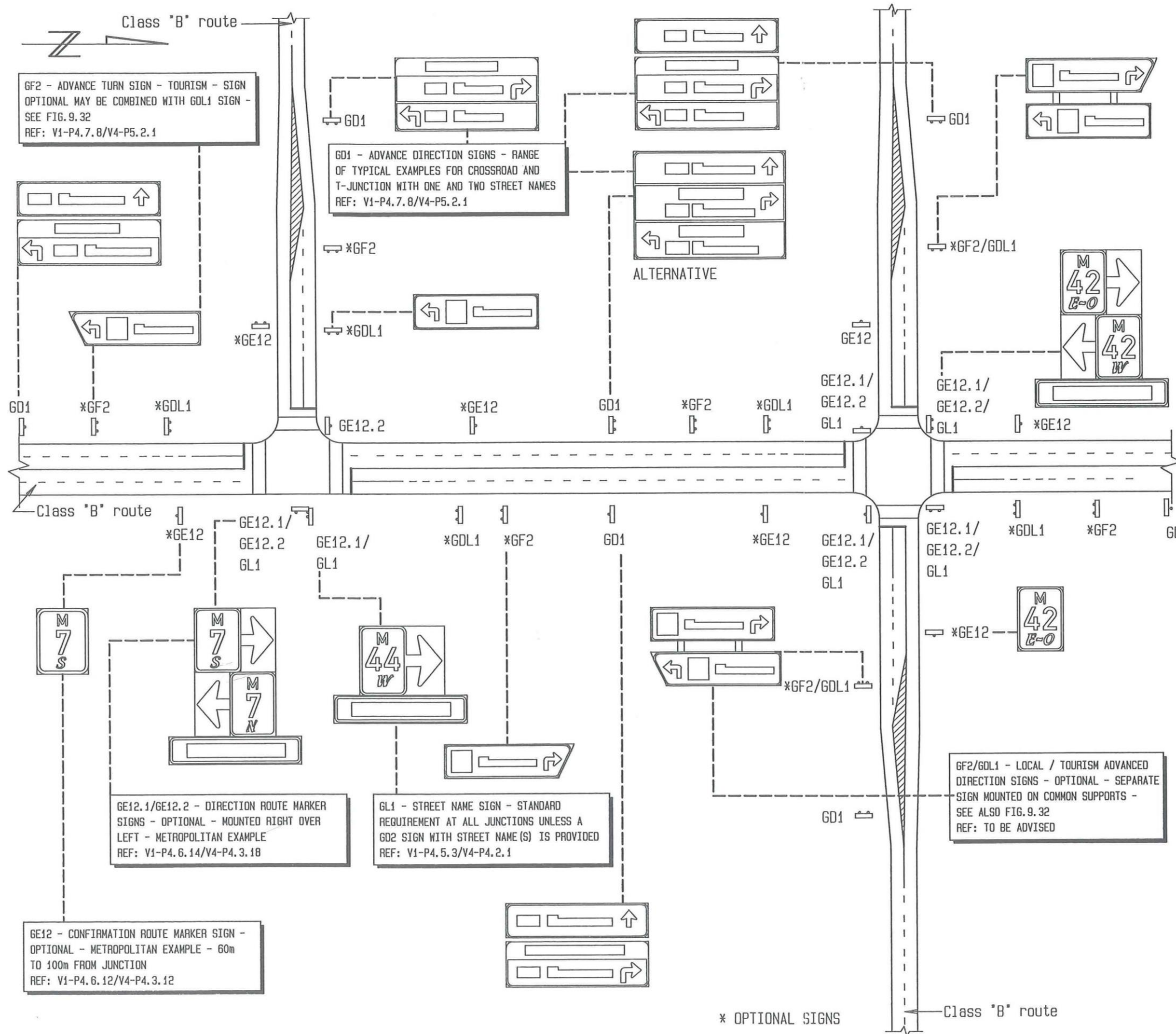

9.6.22 Notes on Figure 9.51

Numbers of Signs Required per Approach

Quantity	Type	Typical Area (m ²)
for a single street name		
1	GD1	15 ₈₀ 8,5 ₆₀
1	GE12*	1-1,4 _(by route type)
for two street names		
1	GD1	18 ₈₀ 10 ₆₀
1	GE12*	1-1,4 _(by route type)

NOTE: * Optional signs

The areas given are based on the following parameters:

- d = 40 mm (letter size 280 mm/200 mm) for 80 km/h (see suffix "80")
- d = 30 mm (letter size 210 mm/150 mm) for 60 km/h (see suffix "60")
- longest place name = 10 letters
- single orientation destinations in all stacks
- signface design to full justification of arrows, route numbers and destinations.

Checklist

One or more of the following factors or questions may require the re-evaluation of the signs provided at an urban Class "B" junction:

- is sign message continuity being maintained?
- is there space on the approach for the GD1 sign?
- are other types of street furniture a problem - service poles and trees?
- is a relaxation of the nearest numbered route warrant justified for the display of GF2 and/or GDL1 signs?**
- is there sufficient space to accommodate additional GF2 and/or GDL1 signs if warranted?
- can a combination GF2/GDL1 sign be used?
- is there competition from advertising signs.

Fig. 9.51
Urban Signing Level 3B
Class "B" Junctions
Intermediate Level 2

9.6.23 Urban Signing Level 4B Class "B" Junctions Minimum Level

1 General

The guidance signing level indicated in Figure 9.49 is the Minimum Level acceptable for urban Class "B" routes. The effect of this minimum level of signing over a length of such a route is illustrated in Figure 9.15. This minimum level of signing may be applied to any Class "B1" or Class "B2" route due to the physical characteristics of the route concerned or as the economic implementation of a system wide signing of all numbered routes in an urban area. Due to the high capital cost of implementing a higher level of signing it is recommended that all towns and cities plan to have in place a minimum level system within the shortest possible time. If it is determined that higher levels are justified, an affordable implementation plan (Urban Guidance Signing Plan) can be drawn up to gradually achieve this objective. A total of four levels of signing are available and are covered in Figures 9.49 to 9.52. It is not recommended that signing levels be altered frequently through successive junctions on a route however. This aspect should be taken into account when formulating the plan.

Figures 9.49 to 9.52 do not include the display of other optional guidance signs such as SUBURB NAME sign GL2 or TOWN or CITY NAME sign GL3. The use of these signs is illustrated in Figure 9.14.

2 Standard Sign Sequence

The following is the basic sign sequence which comprises the Minimum Level of Class "B" route direction signing:

- GE12.1 - (over GE12.2) DIRECTION ROUTE MARKER (METROPOLITAN) signs (mounted RIGHT over LEFT) (other variations include GE13.1/GE13.2 (REGIONAL), GE14.1/GE14.2 (PROVINCIAL) or GE15.1/GE15.2 (NATIONAL) - on the through leg of a T-junction only one sign is required)
- GL1 - STREET NAME sign
- GE12 - CONFIRMATION ROUTE MARKER (METROPOLITAN) sign (other variations include GE13 (REGIONAL), GE14 (PROVINCIAL) and GE15 (NATIONAL)).

3 Sign Positions

The positions recommended for the standard signs in the sequence are:

- GE12.1 - (and GE12.2) in the far left corner of the junction
- GL1 - in the far left corner of the junction closely associated with signs GE12.1 and GE12.2
- GE12 - 60 m to 100 m beyond the junction.

At very wide junctions signs GE12.1 and GE12.2 may be separated to improve their position in terms of the likely driver cones of vision.

4 Optional Signs

The following optional signs may be used to supplement the basic sign sequence (see above):

- GDL1 - ADVANCE LOCAL DIRECTION sign - **subject to compliance with warrants this sign may be introduced on a class "B" route** (see Section 9.4), - the sign may comprise a left stack or a right stack, or both stacks (see GF2 above) - located 50 m to 60 m (80 km/h) or 40 m (60 km/h) in advance of the junction.
- GF2 - ADVANCE TURN (Tourist) sign - **subject to compliance with warrants this sign may be introduced on a class "B" route** or it may continue a message previously displayed on a freeway (or another numbered route subject to the relaxation of the nearest numbered route rule **see Section 9.5 and Chapter 4**), - the sign may comprise a left stack or a right stack, or both stacks - sign GF2 may be combined with sign GDL1 either by providing a single composite sign or by mounting the signs on common supports, subject to the signface rules given in Volumes 1 and 4 - and located 100 m to 120 m (80 km/h) or 70 m (60 km/h) in advance of the junction.
- GL2 - SUBURB NAME sign - to indicate passage from one suburb to another along a numbered route - its role should be considered as secondary to the other standard and optional signs listed above particularly on the exit from a junction within 30 m to 60 m of the suburb boundary.
- GL3 - TOWN NAME sign - to indicate entry into a specific town or city - it should be located so as not to conflict with other guidance signs (accurate location at the town boundary should be considered secondary to avoiding conflict with other signs).

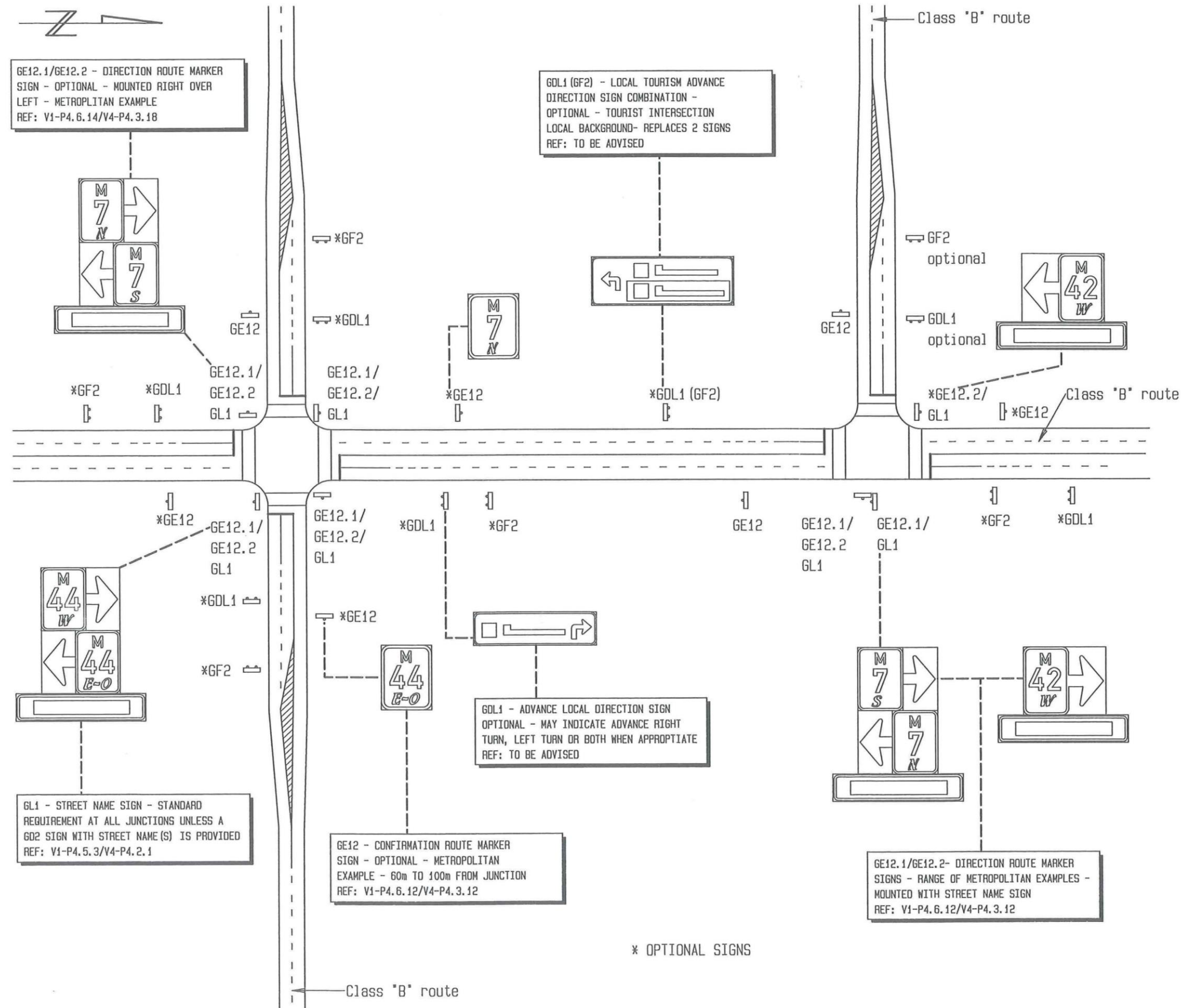

9.6.24 Notes on Figure 9.52

Number of Signs per Approach

Quantity	Type	Typical Area (m ²)
2	GE12*	1-1,4 _(by route type)
1	GE12	0,6

NOTE: * Optional signs

The areas given are based on fixed sign sizes although it is optional to increase these sizes by a factor of 4 over 3 (see Volume 4, Chapter 4).

Checklist

One or more of the following factors or questions may require the re-evaluation of the standard signing sequence listed above:

- will message continuity with an earlier junction be satisfied?
- are the signs adequate in terms of the size of the junction?
- can they be positioned accurately within the driver's cone of vision?
- is a relaxation of the nearest numbered route warrant justified for the display of GF2 and/or GDL1 signs?
- is there competition from advertising signs?

Fig. 9.52
Urban Signing Level 4B
Class "B" Junctions
Minimum Level

9.6.25 Urban Signing Levels 1C and 2C Class "C" Junctions Enhanced and Minimum Levels

1 General

Figure 9.53 shows two sections of Class "C" street. The upper detail shows a Class "C" street intersecting a Class "B" route. These junctions are shown as signalised but may commonly be unsignalised. The Class "B" route will almost always have priority over the Class "C" route unless a 4-way or 3-way stop control, or a traffic circle, is used. If the Class "C" route is operating as a collector-distributor an enhanced level of signing, which includes the display of the intersecting route number, may be considered. The minimum level of signing comprising only STREET NAME signs GL1 should otherwise be specified for all Class "C" streets. The size of lettering used on sign GL1 on Class "B" approaches should be maintained at the recommended size of 140 mm.

2 Sign Position

STREET NAME signs GL1, and any DIRECTION ROUTE MARKER signs specified should be located in the far left corner of the priority approach unless optional signs are used (see below). On a Class "B" route approach to a Class "C" junction this means that the preferred treatment is to provide two GL1 signs particularly if the priority route has 3 or more lanes.

3 Optional Signs

At this local level optional signs as follows may be warranted:

- GE12.1 - (and GE12.2) DIRECTION ROUTE MARKER (METROPOLITAN) sign (other variations include GE13.1/GE13.2 (REGIONAL), GE14.1/GE14.2 (PROVINCIAL) or GE15.1/GE15.2 (NATIONAL)) - located in the far left corner of the junction for the Class "C" (non-priority) approach.
- GE12 - ROUTE MARKER CONFIRMATION (METROPOLITAN) sign indicating the number and class of the intersecting route (other variations include GE13 (REGIONAL), GE14 (PROVINCIAL) and GE15 (NATIONAL)) - located 60 m to 100 m beyond the junction on the Class "B" route.
- GDL1 - ADVANCE LOCAL DIRECTION sign OR GDL2 - LOCAL DIRECTION sign - one of these signs may introduce a local destination for the first time on this class of route (see GF2) - located 40m to 70 m from the junction in the case of sign GDL1, subject to the presence of other supplementary direction signs, or in the far left corner in the case of sign GDL2.
- GF2 - ADVANCE TURN (Tourism) sign OR GF3 - FINAL TURN (Tourism) sign - one of these signs may introduce a tourist destination for the first time on this class of route - signs GF2 or GF3 may be combined with signs GDL1 or GDL2 respectively, either by providing a single composite sign subject to the signface rules given in Volumes 1 and 4 or by mounting the signs on common supports - located 70 m to 100 m from the junction in the case of sign GF2 or in the far left corner in the case of sign GF3.

- GL2 - SUBURB NAME sign - to indicate passage from one suburb to another - located within 30 m to 60 m of the suburb boundary subject to any conflict with other signs.

NOTE: it is at this level that supplementary tourism and local destination signs are most commonly likely to be used in an urban area in the terms of the "nearest numbered route" warrant (see paragraph 9.5.10.5).

Reproduced under Government Printers Authorization (No. 1189) dated 11/11/2011

9.6.27 Urban Signing Levels 1D and 2D Class "D" Junctions Enhanced and Minimum Levels

1 General

Figure 9.54 shows two sections of Class "D" street. One detail shows a Class "D" street intersecting a Class "B" route. The minimum level of signing comprising only STREET NAME signs GL1 should be provided at all Class "D" street junctions. Subject to the speed limit on an intersecting Class "B" route the size of lettering on signs GL1 on the Class "B" approaches should be maintained at the recommended 140 mm letter size.

2 Sign Positioning

STREET NAME signs GL1 should be located in the far left corner of the priority approach. It is therefore recommended that on Class "B" approaches to a Class "D" junction GL1 signs be provided for both directions of approach.

3 Optional Signs

Although other guidance signs may be provided at Class "D" junctions, by virtue of the number of such junctions, the number at which additional signs will be required will be relatively small. For possible optional signs refer to earlier subsections.

The use of GE12 signs on a Class "B" route exit from a junction with a Class "D" route is an option which may be exercised.

Tourism signs GF2 and GF3 may well be specified under the conditions of the application illustrated. Similarly local destination signs GDL1, GDL2 or GDL3 may also be used. These signs may be used on intersecting Class "B" or "C" streets or, particularly as final turn signs if warranted, on Class "D" streets.

Reproduced under Government Printers Authority Licence No. 1002 dated 27 July 2011

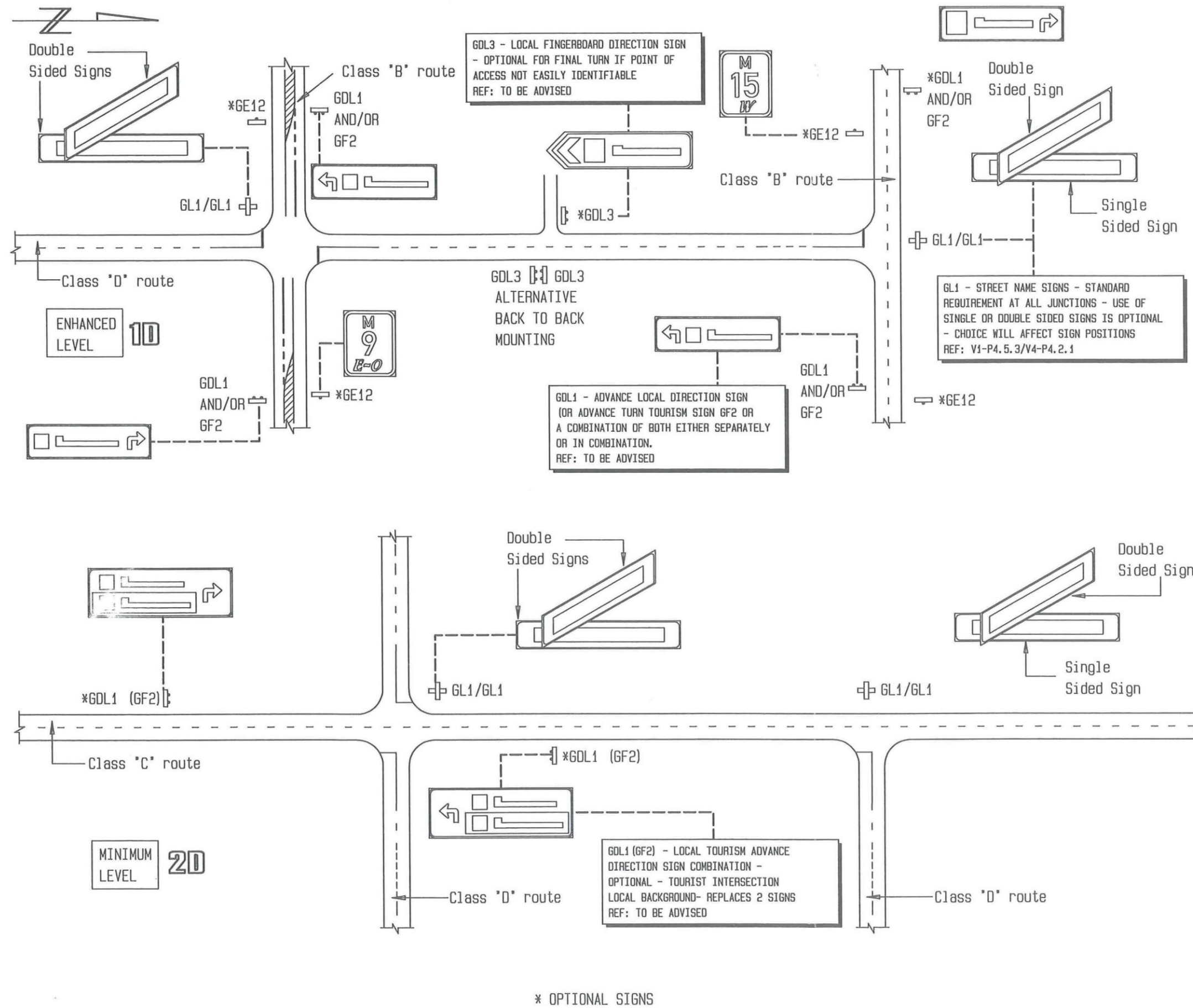

9.6.28 Notes on Figure 9.54

Numbers of Signs Required on Priority Approaches

Quantity	Type	Typical Area (m ²)
1	GL1	0,2 _(average)

The area of STREET NAME sign GL1 can vary widely. The area given represents a sign with a total of 12 letters of 112 mm height in DIN 1451, Style "A". A similar sign using 140 mm high Style "A" letters will be approximately 40% larger.

Checklist

One or more of the following factors may affect the signing treatment of a Class "D" junction:

- if tourist or local direction signs are warranted should these –
 - be mounted separately, OR
 - be mounted together on common supports, OR
 - be provided in a single composite sign
- will the sign be clearly visible in the standard position - if not, can the sign be better located?
- should the sign letter size be increased due to traffic speed or street width.

Fig. 9.54
Urban Signing Level 1D & 2D
Class "D" Junctions
Enhanced and Minimum Levels

9.6.29 Urban Guidance Signing Dual Carriageway Junction with Sliproads

1 General

The general principles for Class "B" route signing also apply to urban dual carriageway streets (see Figures 9.49 to 9.52). Due to the significantly increased road space as a result of the multiple lanes and the dividing median, but particularly due to the increased size of junction created, the use of the Preferred Level of Class "B" route signing (Figure 9.49) is recommended for dual carriageway streets.

A dual carriageway street offers a wider range of options to position signs. These are illustrated in Figure 9.55. The figure shows different options for the same sign in some instances. These options should be exercised on a site specific basis according to the following criteria:

- is correct lane selection (for exclusive right or left lanes) likely to be achieved due to adequate advance signing (GD1)? - if it is considered this will be the case then separate right and left turn GD2 signs may be provided - these signs should then be positioned to suit the most obvious cone of vision of approaching drivers who should have already selected a right or left "biased" lane as a result of sign GD1.
- are left turning slip roads provided? - if they are the GD2 sign should be split and the left turn portion repositioned in relation to the slip road.
- if the central median is very wide it may be beneficial to locate direction signs on the median island (see Figure 9.56 also) subject to there being no worsening of direct sight distances around the signs.

2 Standard Sign Sequence

The basic sign sequence should be the same as is illustrated in Figure 9.49 for urban Level 1B signing.

3 Sign Positions

The positions of sign GD1 should be in advance of the start of any exclusive turn lane. Sign GD1 should also be positioned far enough from the junction to permit the addition of either or both of signs GF2 and GDL1 subject to compliance with the relevant warrants. If these signs indicate a right turn they should also preferably be in advance of the start of any exclusive right turn lane. The separation between such signs should preferably be of the order of 50 m to 60 m. When all signs are provided in separate positions, this may result in sign GD1 being positioned within the range of 240 m to 300 m from the junction.

Subject to the actual junction geometry, and with the objective of obtaining the best possible target value for the GD2 signs, these may be separated if necessary and located in one of the following positions:

- the left turn GD2 at the exit point of a left turn slip road - such a GD2 sign should use a Type 1 arrow inclined 45° to the left of vertical
- the right turn GD2 either in the far right corner of the junction, OR if the junction and median are wide, on the central median opposite the right turn lane(s).

These positions assume that the junction will be controlled by traffic signals.

4 Optional Signs

Additional signs may be provided on a dual carriageway street as indicated in Subsection 9.6.17 for Class "B" junctions **subject to compliance with design criteria relating to the total amount of information placed before drivers, letter sizes used on signs, the spacing between signs and the reading time available in terms of these factors.**

Reproduced under Government Printers Authorization No. 10/2012

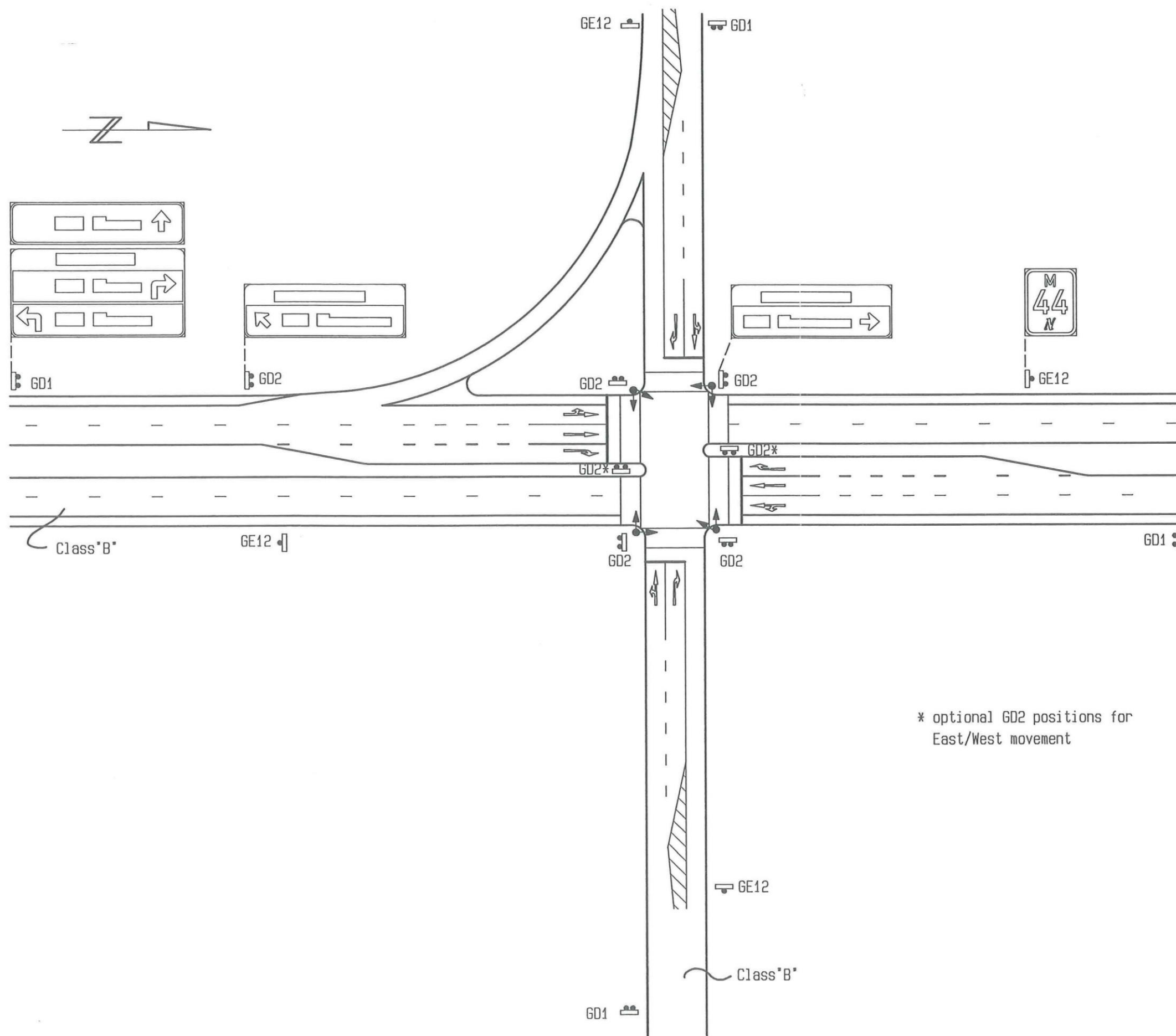

9.6.30 Notes on Figure 9.55

Numbers of Signs Required per Approach

Quantity	Type	Typical Area (m ²)
1	GD1	15 ₈₀ 8,5 ₆₀
2	GD2	4 ₈₀ 2,25 ₆₀

The areas given should be considered as guidelines for general estimating only. They are based on the following very general parameters:

- d = 40 mm for 80 km/h (see suffix "80")
- d = 30 mm for 60 km/h (see suffix "60")
- longest place name = 10 letters
- single orientation destination in all stacks
- signface design to full justification of arrows, route numbers and destinations.

Checklist

One or more of the following factors or questions may require the re-evaluation of the standard display of guidance signs when a Class "B" junction involves dual carriageway roadways:

- does the junction have slip roads?
- does the junction have exclusive left and/or right turn lanes?
- can the central median be considered to be "wide" (greater than 6 m width)
- if signs are positioned within the junction on a median, or on the right side, will sight distance be significantly affected (signalization may reduce the likelihood of a problem occurring due to separation of conflicting movements by signal phasing).

Fig. 9.55
Urban Guidance Signing
Dual Carriageway Junction
with Sliproads

9.6.31 Urban Guidance Signing Dual Carriageway Junction with a Freeway

1 General

The general principles for Class "B" and freeway crossroad signing also apply to urban dual carriageway streets which intersect with freeways at access interchanges (see Figures 9.47 and 9.49).

The geometric treatment of freeway off-ramp terminals can vary quite widely and particularly when the intersection cross street is a dual carriageway. Figure 9.56 illustrates some of the options which may be exercised at such junctions when considering the provision of guidance signs. The nature of the options available is likely to be dictated by the geometric detail of the junctions and all of the options illustrated are unlikely to occur at any one site, however, different options may be used on different ramp approaches or on different cross street approaches.

2 Standard Sign Sequence

The basic sign sequences should be as illustrated in Figures 9.46 and 9.47.

3 Sign Positions

This example indicates a number of circumstances as a result of which sign positions may be varied. When not affected by these circumstances sign positions should remain as indicated in other examples. A description of the standard sign positions is therefore not appropriate to this example.

Reproduced under Government Printers Authority Licence No. 11542 dated 11/11/2011

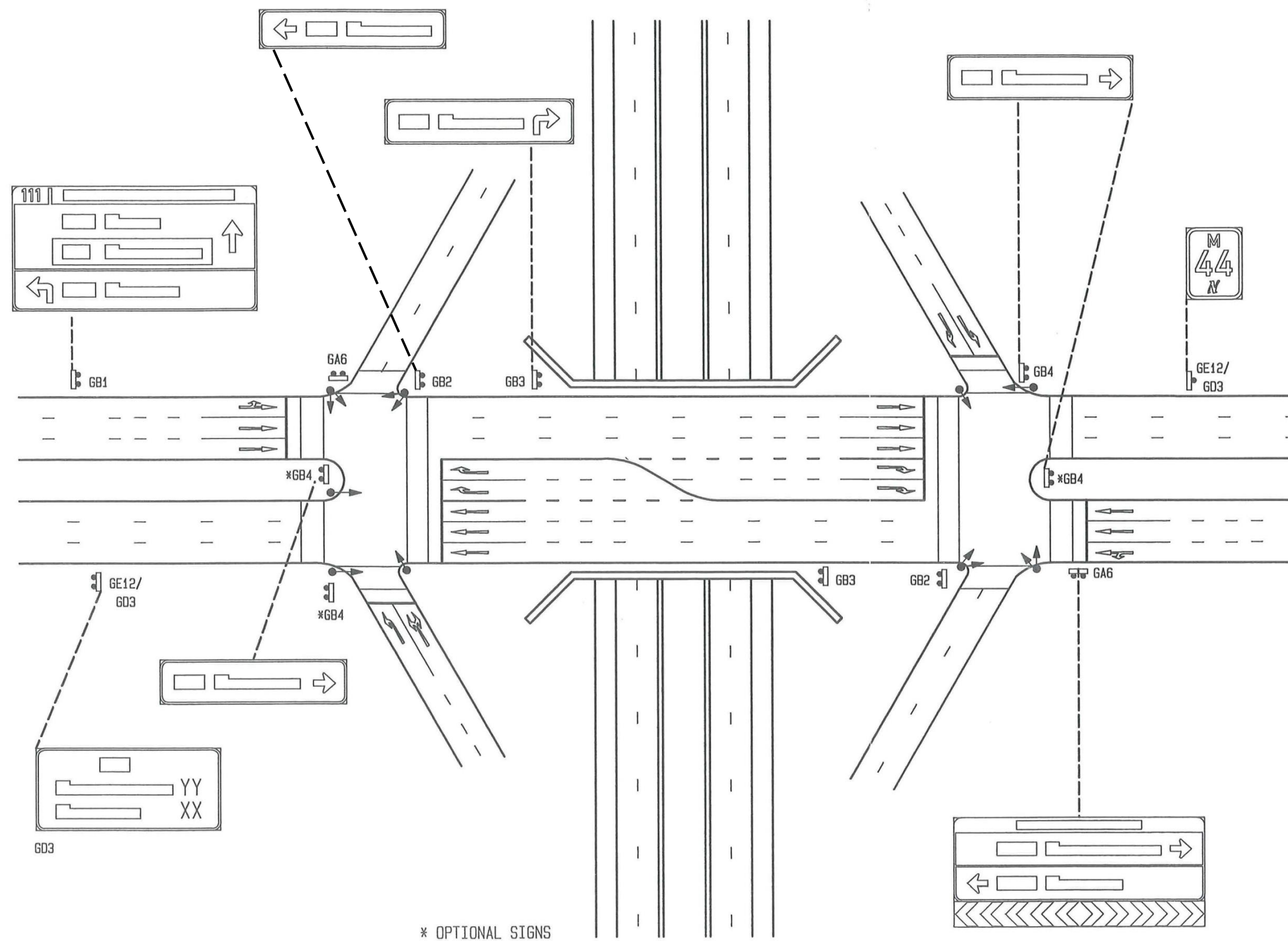

9.6.32 Notes on Figure 9.56

This figure illustrates what are essentially non-standard options to the provision of guidance signs at a freeway crossroad. It is therefore not appropriate to quote a standard sign sequence or average sign areas.

Checklist

One or more of the following factors or questions may require the re-evaluation of the standard display of guidance signs when a Class "A"/Class "B" access interchange involves a dual carriageway cross street;

- does the junction geometry require a non-standard signing treatment?
- if signs are placed in non-standard positions can drivers be expected to see them?
- if signs are placed in non-standard positions can they obstruct a driver's line of sight?
- does the complexity of the geometry warrant consideration of overhead direction signs?

Fig. 9.56
Urban Guidance Signing
Dual Carriageway Junction
with a Freeway

9.6.33 Urban Guidance Signing Diagrammatic Signs Lane Drop Examples

1 General

One of the most common applications of permanent Diagrammatic signs is the indication of a lane drop situation on a multi-lane street. Justification for the use of the Diagrammatic LANE DROP signs GS101 to 106 in an urban environment is not likely to occur frequently. Factors such as higher speeds, high traffic volumes and a broad traffic mix, or limited sight distance may commonly justify the use of LANE DROP signs GS101 to 106. Two examples in Figure 9.57 illustrate typical situations as follows:

- a lane drop from 3 lanes to 2 lanes on a section of dual carriageway
- when making a rearrangement of lane function which cannot reasonably be anticipated by drivers (in this case to generate an exclusive turn lane at the next junction - see Subsection 9.6.37).

When used in advance of a position to which the diagram on the sign refers, a Diagrammatic sign shall only be displayed together with a SUPPLEMENTARY PLATE sign IN11. Sign IN11 shall be placed below the sign and normally will indicate the distance to the point referred to.

The appropriate use of temporary Diagrammatic signs is highly recommended in urban areas when such signs can be accommodated. Temporary applications are covered in Chapter 13: *Roadworks Signing*.

2 Standard Sign Sequence

A typical basic sign sequence which comprises the application of Diagrammatic Lane Drop type signs is as follows:

- GS103 - (plus IN11.3) LANE DROP sign (3 lanes to 2 lanes from the left)
- GS103 - LANE DROP sign (3 lanes to 2 lanes).

3 Sign Positions

In an urban area the distance between an advance sign and the sign marking the point of the lane drop can vary widely. Under free flowing traffic conditions the advance sign should be positioned in the range of 100 m to 300 m in advance of the point at which the lane is dropped. The second sign in the sequence should be within 20 m to 25 m of the lane drop position (defined by the start of the taper). Positions should be adjusted to take into account vertical and horizontal curves and other obstructions to sight distance (e.g. trees).

4 Signing Options

Space considerations may preclude the provision of two signs in a sequence. Either an advance sign on its own or a single sign at the "action" point may be provided if the improved target value of one sign is required in preference to a standard warning sign.

On high speed streets two advance signs may be used. Such signs should normally be positioned at distances such as 100 m AND 300 m in advance of the "action" point. In terms of this type of treatment the sign at the "action" point may be dispensed with.

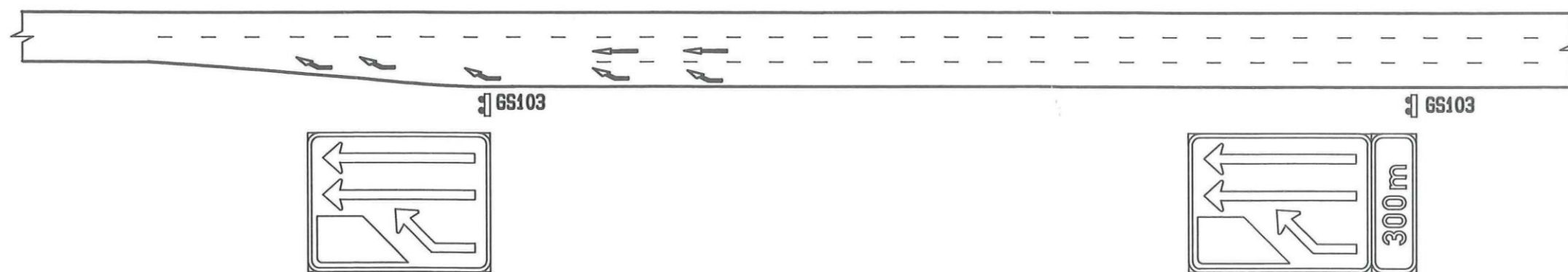

Detail 9.57.1 Lane Drop on Dual Carriageway.

9.6.34 Notes on Figure 9.57

Numbers of Signs Required

Quantity	Type	Typical Area (m ²)
2	minimum size	2,5 (or similar) (including IN11.3)
	GS101	
2	Standard size	4,25 (or similar) (including IN11.3)
	GS101	

Checklist

The following factors should be taken into account when considering the application of urban Diagrammatic signs of the Lane Drop type (any sign indicating a traffic "obstruction" of some sort):

- is the condition being signed clearly visible to drivers? - if yes, are signs really necessary?
- do traffic volumes make visibility of the lane drop condition difficult?
- will warning signs be adequate given their smaller target area but specific warning message?
- the provision of Diagrammatic signs may not only benefit the safe operation of the site but may improve traffic flow due to the improvement in information displayed
- should the geometry of the site ultimately be revised to remove the need for the signs?

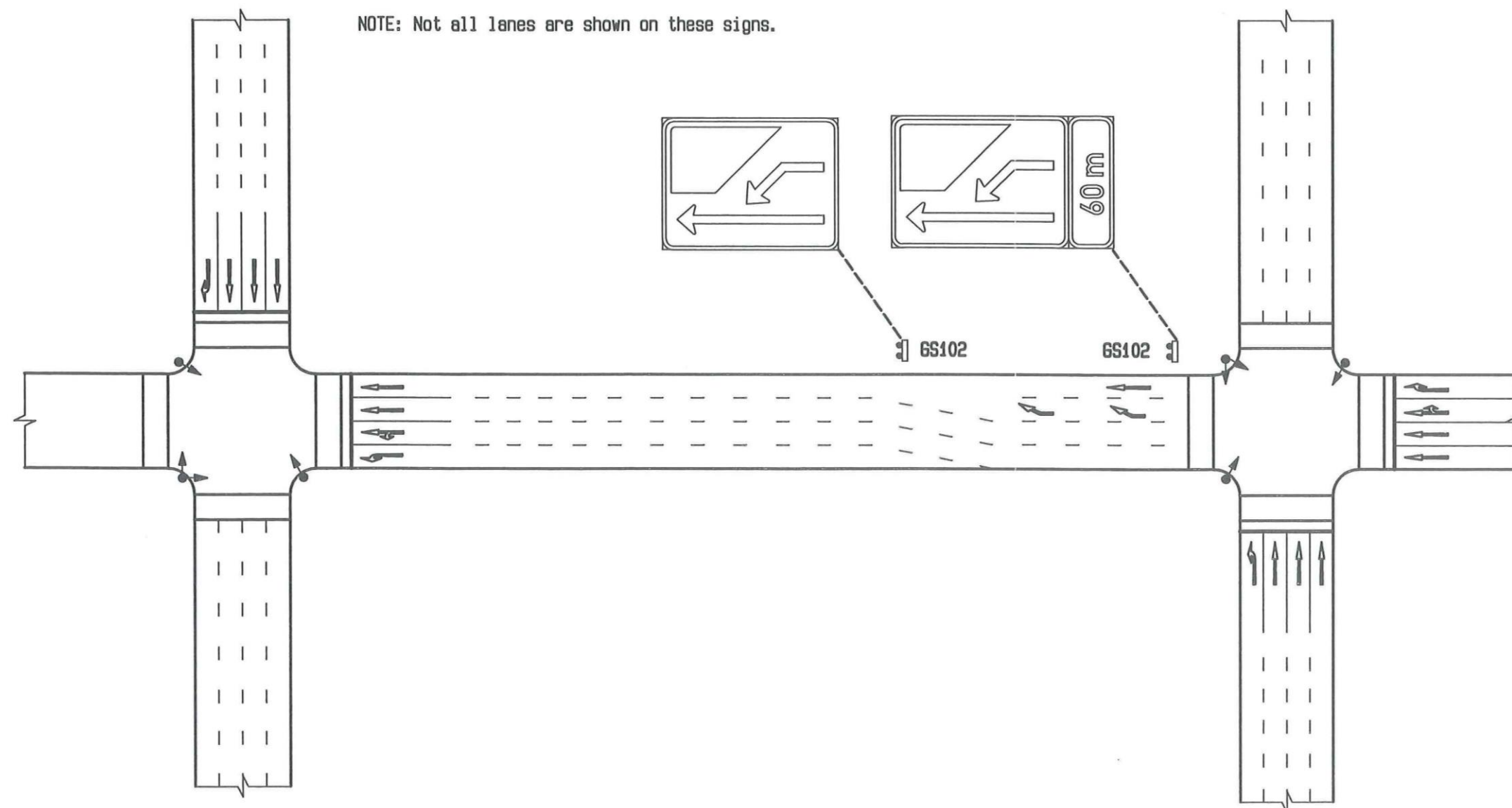

Detail 9.57.2 Lane Drop on a One Way Road (CBD)

Fig 9.57
Urban Guidance Signing
Diagrammatic Signs
Lane Drop Examples

9.6.35 Urban Guidance Signing Diagrammatic Signs Various Examples

1 General

Figure 9.58 shows a limited selection of typical applications of Diagrammatic signs which may be appropriate in urban areas. In the majority of instances a Diagrammatic sign is shown where a smaller warning sign might otherwise have been appropriate, but for some reason has proved ineffective, or, due to the signface limitations of a warning sign which cannot depict the full message required. If an appropriate warning sign is available its target value can be increased to that of a diagrammatic sign by means of a high visibility background. This may be more effective than using a diagrammatic sign.

The types of situation illustrated will tend to be best served by a sign located at or very close to the "action" point although a second sign, in advance, may still be used if space permits.

The availability of Diagrammatic signs should not be used as an excuse for providing sub-standard road geometry

Reproduced under Government Printers Authorization No. 11542 dated 7th July 2011

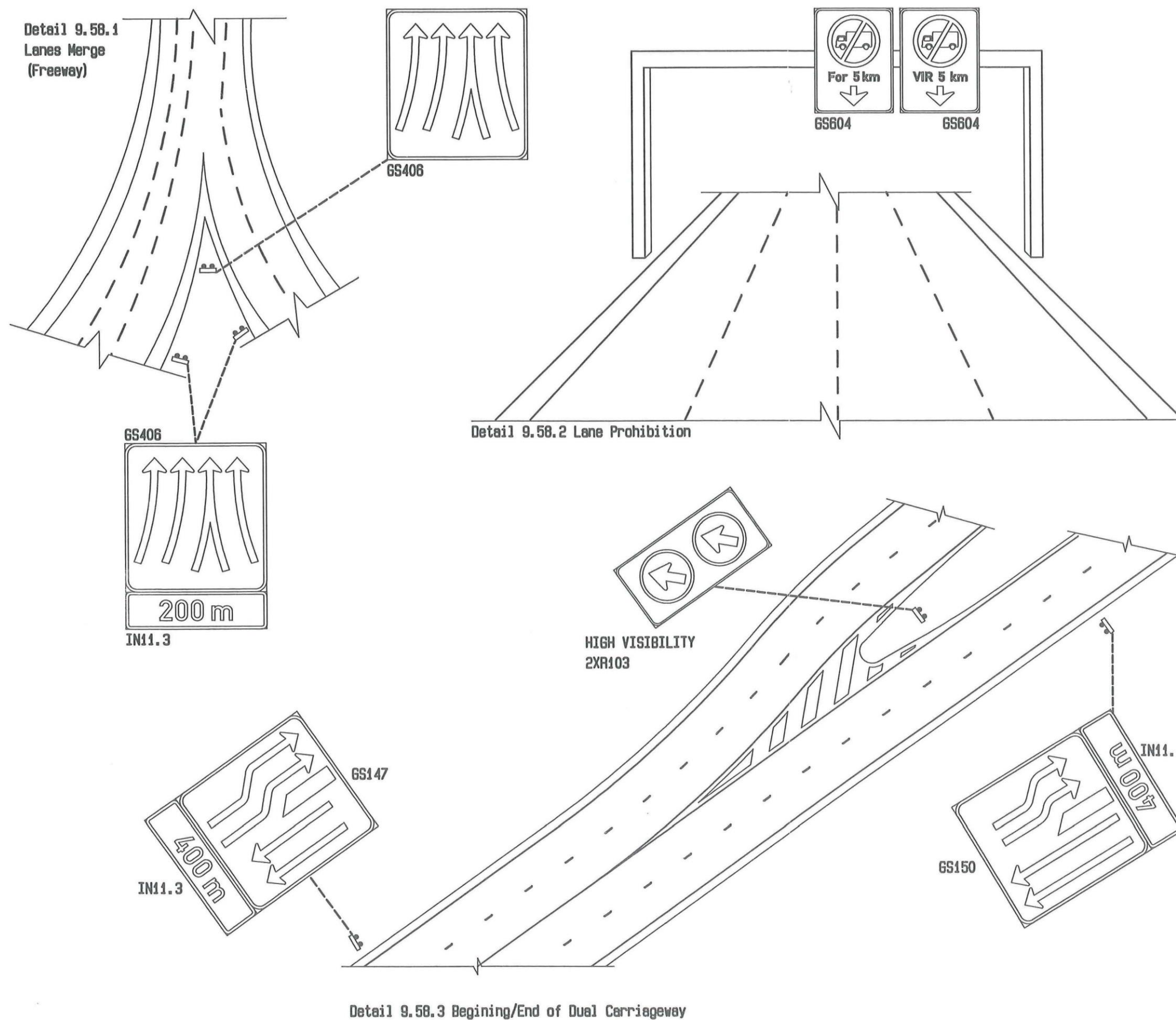

9.6.36 Notes on Figure 9.58

The approximate areas of a single standard sized Diagrammatic sign are as follows:

1200 mm(H) x 900 mm(W) 1 m² (0,3 m²)

1600 mm(H) x 1200 mm(W) 2 m² (0,5 m²)

2400 mm(H) x 1800 mm(W) 4,3 m² (1 m²)

These sizes will be increased by up to 20% if the number of lanes depicted exceeds 3 lanes. The approximate area of an additional SUPPLEMENTARY PLATE sign IN11 is indicated in brackets.

Checklist

The following factors should be taken into account when considering the application of urban Diagrammatic signs of the Lane Drop type (any sign indicating a traffic "obstruction" of some sort):

- is the condition being signed clearly visible to drivers? - if yes, are signs really necessary?
- do traffic volumes make visibility of the condition difficult?
- will warning signs be adequate given their smaller target area but specific "warning" message?
- the provision of Diagrammatic signs may not only benefit the safe operation of the site but may improve traffic flow due to the improvement in information displayed
- should the geometry of the site ultimately be revised to remove the need for the signs?

Fig. 9.58
Urban Guidance Signing
Diagrammatic Signs
Various Examples

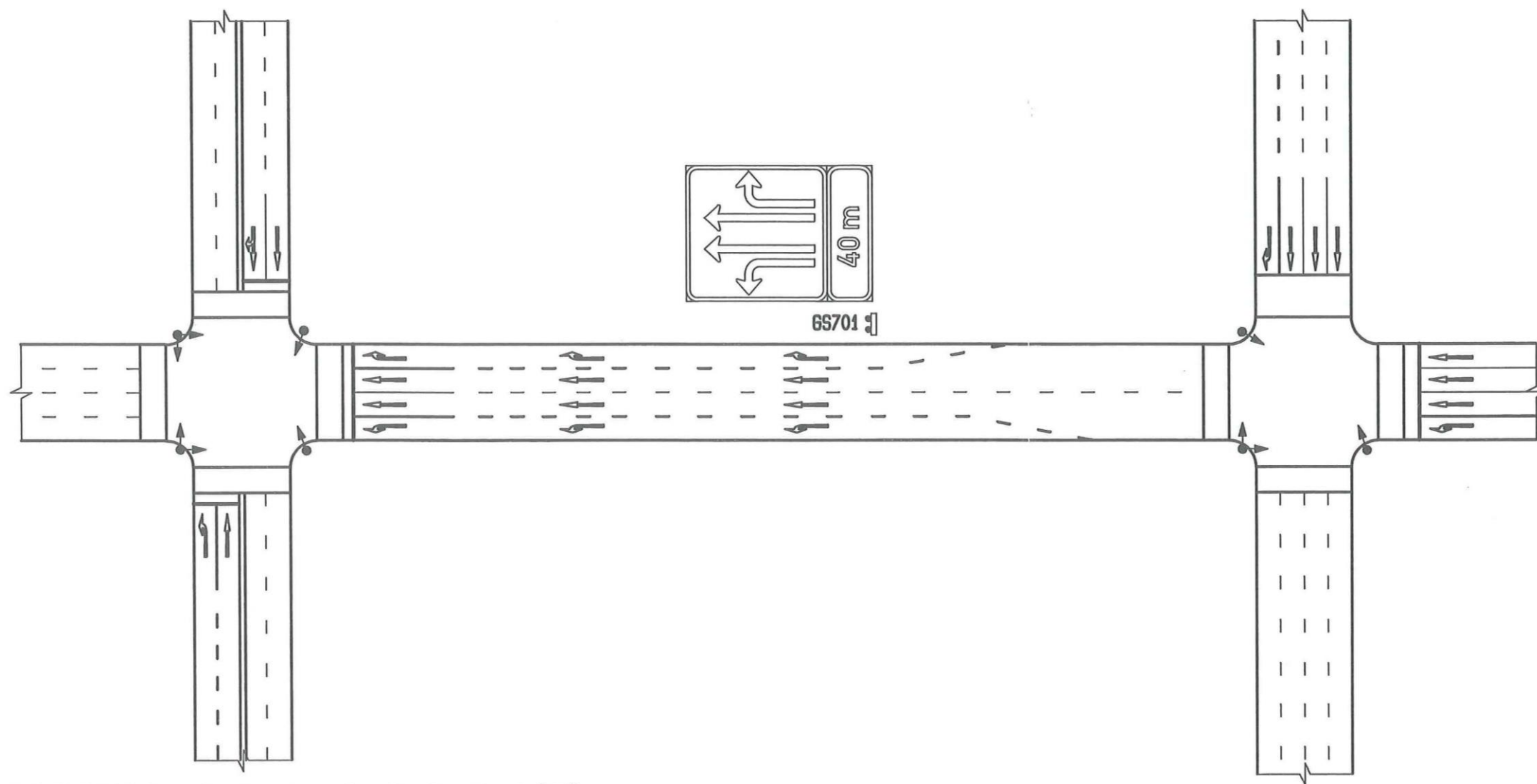

Detail 9.59.1 Exclusive Turn Lanes in a One Way Street (CBD)

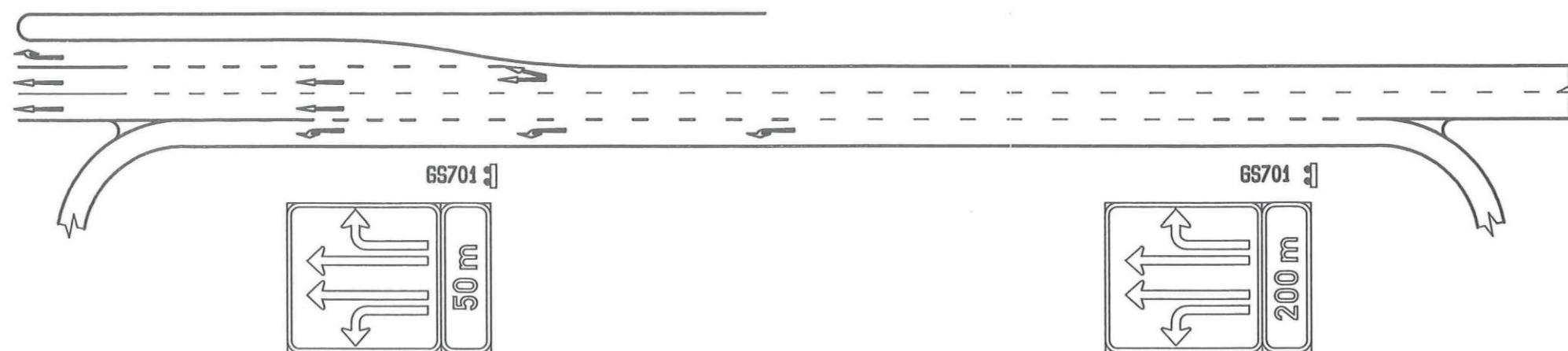

Detail 9.59.2 Exclusive Turn Lanes:
 (i) Typical Dual Carriageway Class "B" Route
 (ii) Weaving Section

9.6.38 Notes on Figure 9.59

Numbers of Signs Required

Quantity	Type	Typical Area (m ²)
2	minimum size	1,35 (or similar) <small>(including IN11.3)</small>
	GS701	
2	Standard size	2,4 (or similar) <small>(including IN11.3)</small>
	GS701	

These sizes will increase by up to 20% if the number of lanes depicted exceeds 3 lanes.

Checklist

The following factors should be taken into account when considering applications of urban Diagrammatic signs of the Exclusive Turn Lane type;

- are drivers making vary late lane changes on the approach to the junction?
- are drivers making illegal movements in terms of the MANDATORY TURN ARROW markings RM8 at the junction?
- does traffic regularly cover road markings which would otherwise clarify the situation?
- can the sign be positioned effectively and be of an effective size?

Fig. 9.59
 Urban Guidance Signing
 Diagrammatic Signs
 Exclusive Turn Lane Examples

Reproduced under Government Printers Authorization No. 11542 dated 7th July 2011

9.7 PROPERTY IDENTIFICATION

9.7.1 General

- 1 Throughout this chapter reference has been made to the need for effective property identification or numbering. 'Signs' or other devices displaying property numbers are not road traffic signs. They are, however, from the point of view of the unfamiliar visitor to a property, the ultimate 'LOCATION' sign since their message states, in effect, 'You are here - you have reached your destination'. This section has been added to this chapter to give local authorities a limited guide to the provision of effective property identification.
- 2 The ability to identify a specific property quickly is of primary importance in minimising the response time of emergency services such as police, fire and hospital services. If these services are called it could be crucial to the saving of life that they do not drive around searching for the correct property.
- 3 Occupiers of properties should therefore be encouraged to display the street number of their property in a legible and consistent manner. When appropriate, this should be in addition to any aesthetic numbering treatment used as part of the building architecture. The identification of properties in this way should apply irrespective of the land use to which the property is put i.e. residential, commercial, local authority, local destinations and tourist destinations, and it should apply throughout urban and peri-urban areas.
- 4 It is most unlikely that a local authority will be prepared to provide the means to identify individual properties without passing on the costs to property owners or occupiers. However, as has been noted, it is desirable that this identification be provided. Local authorities are recommended to adopt one of the following options:
 - (a) create by-laws relating to the mandatory provision of a standard method (or methods) of property identification by all property occupiers; AND
 - (b) prepare a tender for the installation of standardised property numbers (practically such a tender may require to run for some years to cater for larger towns and cities) - recover the cost from each property occupant through a small monthly surcharge to the rates and services account over a period of 6 to 12 months; OR
 - (c) allow private enterprise to contract with individual property owners to provide property identification in accordance with by-laws.
- 5 Two basic methods of providing property identification are described in subsequent subsections. It is recommended that the principles of these methods be adhered to i.e. letter sizes, but that reasonable freedom be permitted to vary the other physical aspects of design or manufacture, subject to adequate quality and performance being achieved. A local authority, in preparing by-laws and/or contract specifications should decide whether it wishes to permit only one or the other, or both methods of numbering. If both are to be permitted it is recommended that the manner in which the two methods may be mixed, or not, should be made very clear. The two basic

methods of identification can be classified as follows:

- (a) ground surface display (adjacent to vehicle entrance);
- (b) property boundary display.

9.7.2 Ground Surface Property Identification

- 1 Figure 9.60 illustrates the basic parameters of this type of property identification device and typical applications of the device. The device should have the following characteristics:
 - (a) block:
 - (i) height = 50 mm;
 - (ii) width = 110 mm;
 - (iii) length = 200 mm;
 - (iv) side slopes = 45° (all four sides of the block should slope in towards the top);
 - (v) shaping - all intersecting faces to be rounded to eliminate sharp edges and corners;
 - (b) lettering:
 - (i) font - a non-serif font such as that used on road signs (DIN 1451 Part2, Styles AA, AB, or AB MOD) or Helvetica should be used;
 - (ii) height = 50 mm;
 - (iii) width = +/- 30 mm subject to the numeral/letter/font;
 - (c) colours:
 - (i) block - black semi-matt (non-retroreflective);
 - (ii) lettering - white retroreflective in accordance with SANS 1519-1:2006 and 1519-2:2004 - Classes I, II or III material may be specified;
 - (d) positioning:
 - (i) at the vehicle entrance - the block should be located on the top of kerbing - on the side of the entrance furthest from the nearest erf boundary;
 - (ii) when no kerbing is present - on the road surface - the block should be located in the centre of the vehicle entrance or driveway to the property as near to the channel as practical.
 - 2 It should be noted that before specifying the use of this type of device a local authority should satisfy itself with regard to the possibility of it being classified as an 'obstruction' within the road reserve. The legal aspects of placing this type of device within a road reserve are not clear, but test installations of devices to the dimensions given above have not identified any specific hazard related to their use on the road surface. Notwithstanding this, care should be exercised in the vicinity of cycle paths and sidewalks.
- ### 9.7.3 Property Boundary Display
- 1 Figure 9.61 illustrates dimensional details and typical applications of this type of property identification device. The installation of this type of identification device is intended to be
(continued on page 9.7.4)

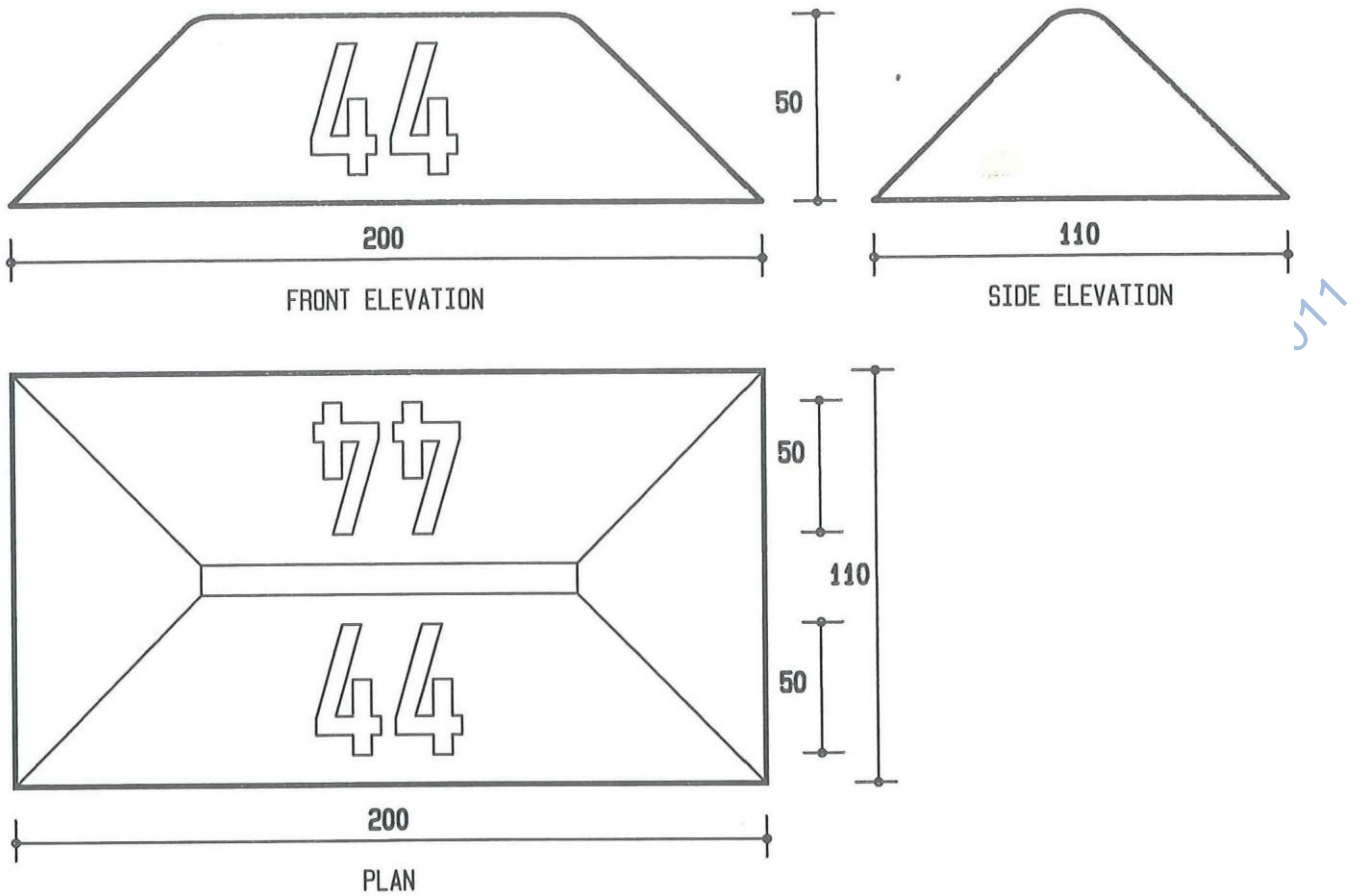

Detail 9.60.1 Recommended Dimensions

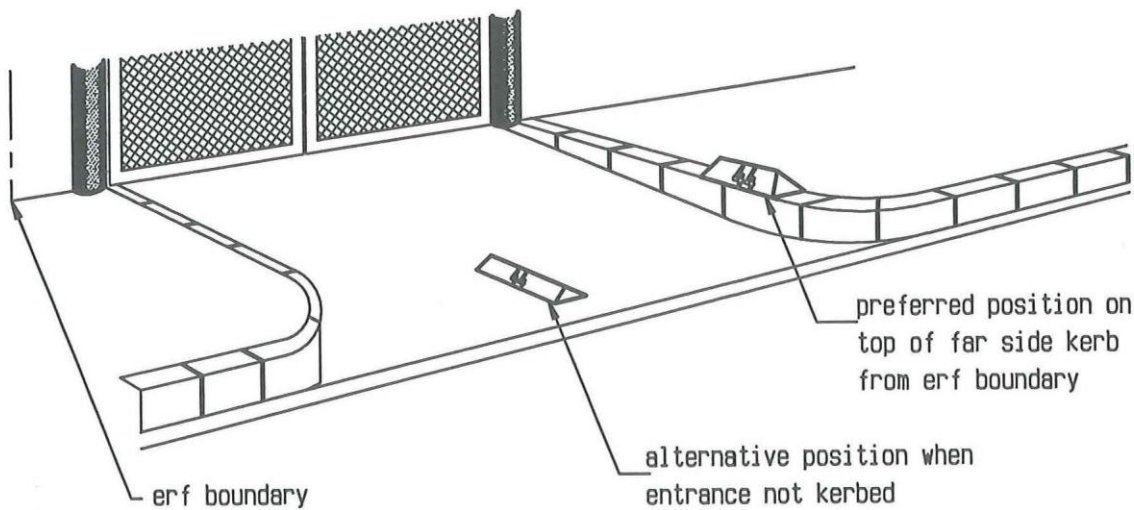

Detail 9.60.2 Positioning of Property Numbers

Fig 9.60

Ground Surface Property Identification

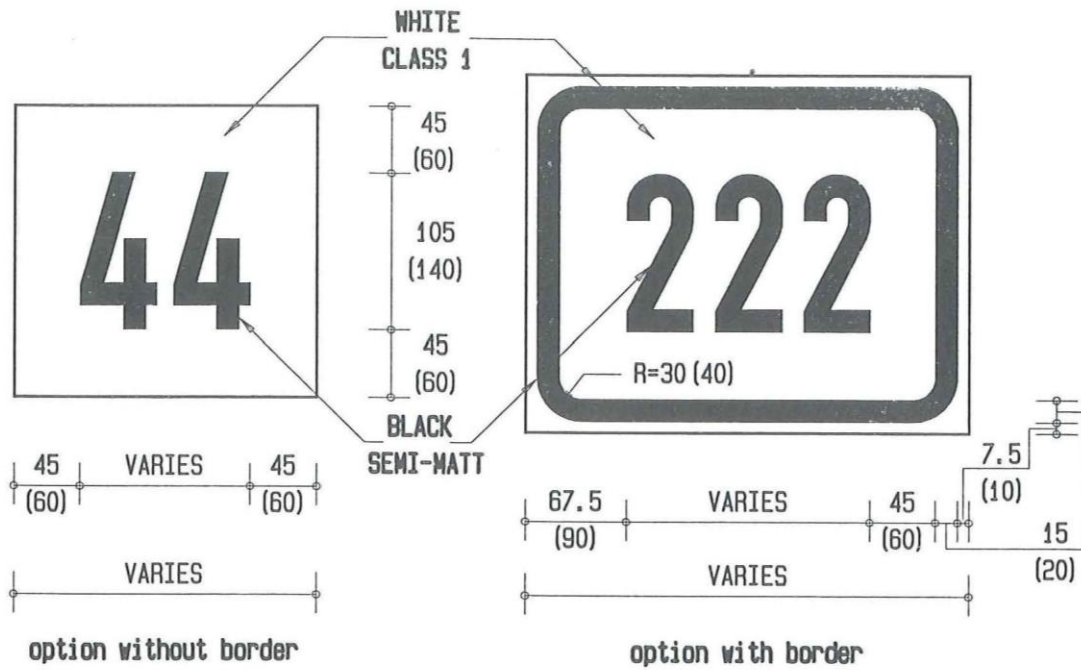

NOTES :

1. Examples show DIN A numerals - DIN B signs will be +/- 20% longer.
2. Numbers in brackets are minimum for 10m to 25m setback from edge of road.

Detail 9.61.1 Recommended Dimensions

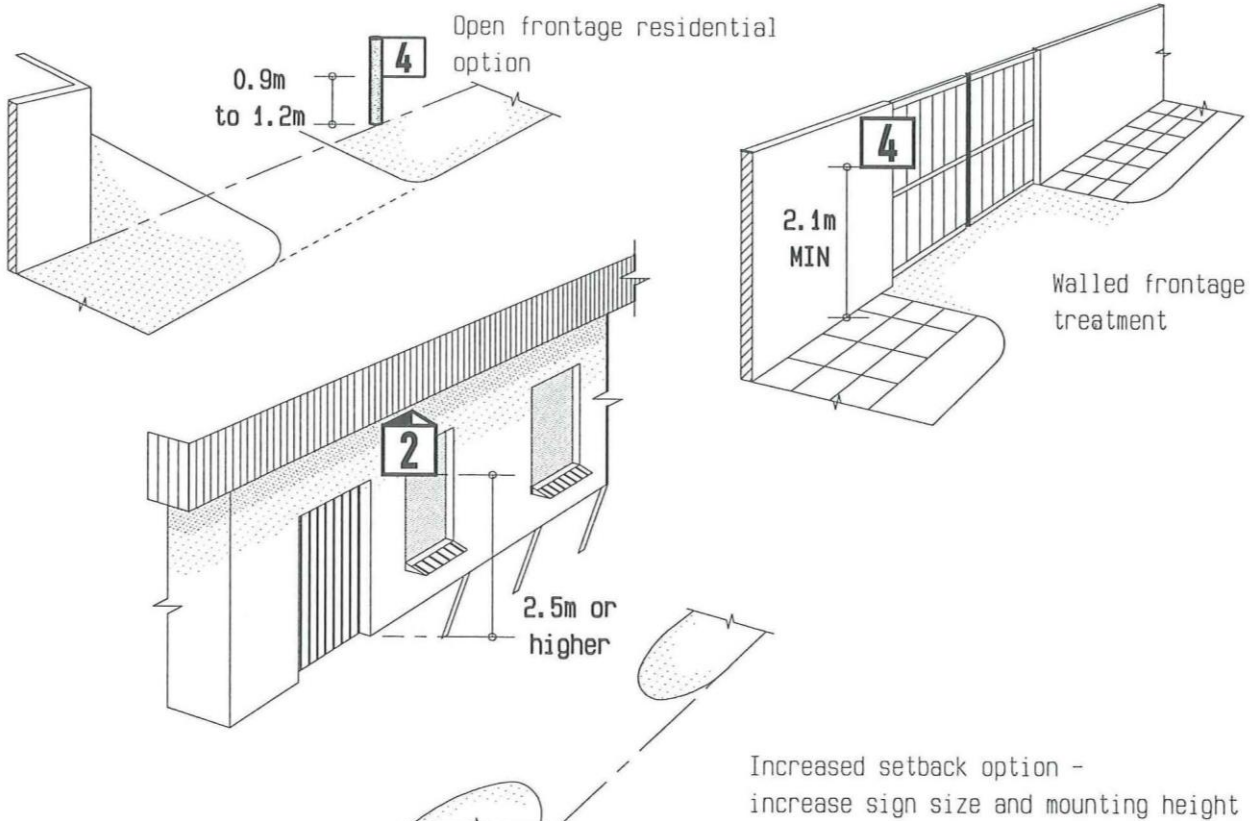

Detail 9.61.2 Examples of Vertical Positioning

Fig 9.61

Property Boundary Identification Display

(continued from page 9.7.1)

on, or very close to, the property boundary. The number display should be at 90° to the property line and should be double sided.

- 2 Due to the position above ground level, it is recommended that normal road sign design principles should apply, namely:

(a) letter size:

- (i) 105 mm minimum when the wall fence or boundary line is 3 m to 10 m back from the edge of roadway;
- (ii) 140 mm minimum if the number is displayed on a building face set back a further 5 m to 16 m;

(b) colours:

- (i) background - white or other light retroreflective colour (the choice of colour should be co-ordinated for a street);
- (i) letters/numbers - black or other dark semi-matt colour (the choice of colour should preferably be co-ordinated for a street).

- 3 The identification device may be located at a number of different heights above ground level. Ideally the device should be in the range 0,9 m to 2,5 m. Attention to the following details is relevant:

- (a) if the device projects over a sidewalk it should be mounted at a height in excess of 2,1 m;
- (b) if there is a low fence or no fence to the property a height of 0,9 m to 2,1 m is preferable;
- (c) the higher the device is mounted the larger it should be sized for adequate night time vision;
- (d) the further back from the road the device is mounted the larger it should be sized;
- (e) if the device is to be mounted flush with the property boundary, and cannot for some reason be mounted at 90° to the boundary, it should be mounted between 1 m and 2 m above ground level.

Reproduced under Government Printers Authorization No. 11542 dated 7th July 2011